

Australian 5G Innovation Initiative
Department of Infrastructure, Transport, Regional Development and Communications
GPO Box 594
Canberra ACT 2601

December 11, 2020

Consultation on the design of the Australian 5G Innovation Initiative
– ITS Australia Submission

We commend the Commonwealth Government for both undertaking the 5G Innovation Initiative and providing this opportunity to engage on the design of this important activity to develop 5G testbeds and trials aiming to try new and innovative technology solutions by offering businesses the opportunity to identify problems and technological solutions that take advantage of 5G's capabilities.

Recent research led by ITS Australia, delivered by the University of Melbourne and supported by the Department of Infrastructure, Regional Development, Transport and Communications through the iMOVE CRC reveal that cutting-edge digital communication technologies, allowing cars to intelligently interpret their surroundings and alert drivers to potential hazards, could reduce vehicle crashes by up to 78 per cent.

The eight-month project involved a comprehensive analysis of Victorian traffic accident data from 2006-2019 and state-of-the-art traffic micro-simulation studies from within the Australian Integrated Multimodal Ecosystem (AIMES).

Researchers focused on understanding cooperative intelligent transport system (C-ITS) technologies that would help drivers in eight main use cases offering benefits in a number of ways including; lane guidance, curve speed, collision avoidance, do not pass and blind spot warnings, intersection movement and right turn assistance, plus pedestrian safety messages.

Professor Majid Sarvi, Lead of Transport Technologies at the University of Melbourne said "Our analysis of Victorian Road Safety data shows that with eight significant connected safety focuses, we have the ability to reduce the incidence of crashes by up to 78 per cent and make vehicle transport safer for all road users."

Traffic micro-simulation experiments were conducted in Melbourne's arterial corridors within AIMES. Researchers concluded that if just 30 per cent of all vehicles on the roads were connected vehicles during peak hour, traffic congestion could be driven down by up to 11 per cent.

A separate network micro-simulation in Melbourne's CBD during peak hour (pre-COVID-19) found that average travel speeds could improve by up to 10 per cent if a fifth of cars were connected vehicles.

While this research covered a range of communications protocols including DSRC, Cellular V2X and 5G applications were included and there are a number of serious benefits including safety and efficiency that we feel would be important to consider as potential use cases for trials in the scope of the Initiative as well as the already identified freight and logistics areas.

Intelligent transport systems (ITS) enabled by new technologies such as 5G encompass road and rail networks which can exchange information with other vehicles and their surroundings. The driver, or in the near future an automated system, can exchange information on incidents that may put at risk the vehicle and its passengers, such as collisions with other vehicles, road works, weather conditions, etc. Connected and automated transport is among the new and revolutionary services that 5G connectivity will fully enable.

To provide examples of a range of areas where 5G activation could offer connectivity through V2X and other C-ITS applications ITS Australia member Kapsch has provided the attached document offering an overview of both the systems and operations and 5G applications that could support a range of important use cases.

If there is interest in a more detailed briefing of the research referenced or in-depth information on some of the examples included that highlights some real-world applications of 5G please contact

[REDACTED]

Yours sincerely,

[REDACTED]

[REDACTED]

ITS Australia Background

ITS Australia is the peak group representing over 120 public and private organisations delivering on transport solutions and technology improving Australia’s road and transport networks and promotes the development and deployment of advanced technologies to deliver safer, more efficient and sustainable transport across all public and private modes – air, sea, road and rail.

Established in 1992, ITS Australia is an independent not-for-profit incorporated membership organisation representing ITS suppliers, government authorities, academia and transport businesses and users. Affiliated with peak ITS organisations around the world, ITS Australia is a major contributor to the development of the industry.

As set out in the Strategic Plan 2018-2021 our vision is to shape future transport to be safe, efficient and environmentally sustainable through the implementation of Intelligent Transport Systems. Our mission is to:

- Advocate for, and inform discussion about, ITS;
- Facilitate collaboration and partnering amongst industry, government and researchers;
- Support research, development and the deployment of ITS technologies;
- Influence and guide the successful development of the ITS industry.

itsaustralia
Intelligent Transport Systems

PLATINUM MEMBERS

CUBIC™ kapsch >>> Queensland Government Transurban VICTORIA State Government Department of Transport

GOLD MEMBERS

Department of Infrastructure, Transport, Regional Development and Communications BOSCH Invented for life DATA 61 GHD hmi iag mainroads WESTERN AUSTRALIA National Transport Commission ntc Leading change

NEC neuron NSW GOVERNMENT PTV GROUP the mind of movement Government of South Australia Department of Planning, Transport and Infrastructure seeing machines TRANSMAX

SILVER MEMBERS

AECOM amsun aldrige ARCADIS ARUP ATC aurecon AXIS BARTCO BRAUNTS CARIS consolis.com.au CBS SYSTEMS CEOS

cloq CISCO Cohda Wireless DACTRONICS DIRECTED DM EastLink EASY MILE EXCEL Technology Co Flanders Ford GEWI ofacconsultants here

CIVIX INVOX indra Integrate inokomatics JI-LED Jacobs JAVANET JWW Keolis Downer W W Lifting&S

LINK Community Transport LOGIX madison MICRO connect MOBILITY MONASH UNIVERSITY moovit netBI NHVR NOKIA Novartis SICK SICK Sensor Intelligence SIEMENS SILLCON Digital Resilience

RACQ RACV RACV COMMUNITY TRANSPORT Redflex RFI RMIT UNIVERSITY Routematch SAGE scriptus Sanyo Gator Group SICK SICK Sensor Intelligence SIEMENS SILLCON Digital Resilience

SKEDGO solace Synchronic SVSTRA otca T TMC TOMTOM TOYOTA traffic TSC transdev Transicare transcolim

UGL UTS VAISALA venta vitronic WESTBYN WSP

Kapsch TrafficCom Australia

5G Innovations and Use Cases

in ITS Applications

9th December 2020

David Bolt

VP Sales & Solution Consulting (APAC)

TABLE OF CONTENTS

- II – Project Narrative1
- 1. Introduction2
- 4. Transportation systems and services5

LIST OF FIGURES

- Figure 0. Kapsch Connect Road Solutions2
- Figure 1. Three Layer Architecture Pyramid3
- Figure 2. Traditional Traffic Management Strategies vs. expanded Traffic Management Strategies possible on the Connected Mobility Platform5
- Figure 3. Road Works Warning6
- Figure 4. Automated Incident Detection7
- Figure 5. DLVP System Object Detection8
- Figure 6. Hazmat Detection8
- Figure 7. CMCC Automated Monitoring and Results11
- Figure 8. CMCC Map Message Builder12
- Figure 9. Live Data Monitoring13

COMPANY HISTORY

Kapsch TrafficCom. (Kapsch) is a leading global provider of connected mobility and intelligent transportation systems (ITS) solutions focused on traffic and critical infrastructure management, tolling, urban access, road safety enforcement, commercial vehicle operations, mobility as a service and V2X connected vehicle systems. Kapsch TrafficCom, based in Vienna, Austria, has subsidiaries, offices and over 4,800 employees in 33 countries.

Kapsch is one of the most established advanced transportation and congestion management technology providers for critical highway infrastructure in Europe, North America, South America and the Oceania, Asia-Pacific region. We provide a full suite of products and services to support the planning, design, implementation and operations of ITS solutions, with a specific focus on ATMS, ITS, Supervisory Control and Data Acquisition (SCADA), facilities management, and information management systems.

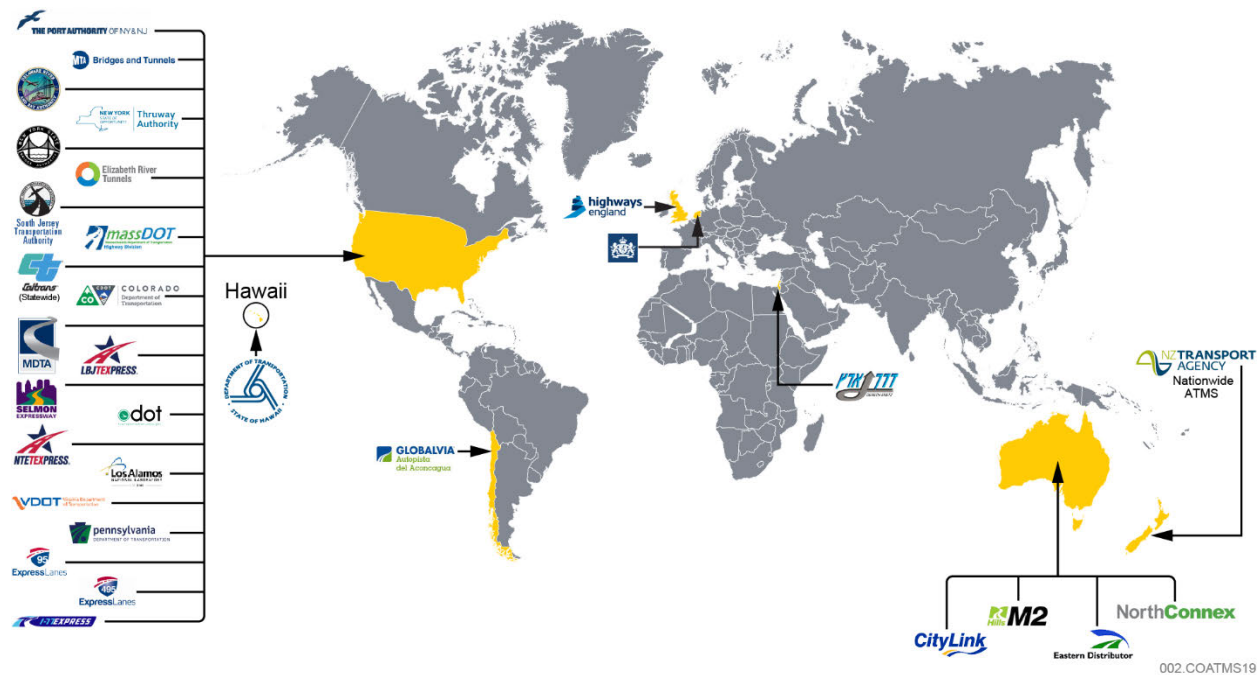

Figure 0-1. Worldwide ATMS Deployments

II – PROJECT NARRATIVE

INTRODUCTION

Kapsch has extensive experience implementing and managing connected vehicle (CV) solutions. Kapsch has delivered Dedicated Short Range Communication (DSRC) and Cellular V2X (C-V2X) roadside units (RSUs), on-board units (OBUs) in a variety of vehicles, roadside control units (RCUs) to enhance existing functionality for other vendors RSUs, and comprehensive management solutions. We have also integrated a variety of external systems, including traffic management systems, traffic controllers, and data management systems and delivered solutions on-time and on-budget in very complex environments.

Kapsch has delivered CV technology solutions in locations across North America, including Ohio, Michigan, North Carolina, Calgary, Ontario, Quebec, and in Colorado. In Colorado, our RIS-9260 dual-band (DSRC and C-V2X) RSU is the backbone of their large-scale, production-level CV implementation. The RSU was adapted from our RIS-9160 DSRC RSU into a first-ever dual-mode DSRC/C-V2X RSU. This adaptable design removes investment risk for roadway operators as the CV industry determines a single V2X communication technology. We regularly build this type of innovation into our solutions. The RSU received certification by the Federal Communications Commission (FCC) on June 4, 2018 and both of our RSUs received OmniAir certification in 2019. Figure 0 depicts the various interrelated Kapsch technology solutions.



Figure 0. Kapsch Connect Road Solutions

Kapsch envisions deploying a technology neutral ecosystem combining V2X infrastructure with mobile sourced vehicle corridor data which offers NCTCOG flexibility and breadth of services to regional customers, scalability towards future expansion, and sustainability for the continually evolving V2X industry. The system would merge Connected Vehicle corridor data with the NCTCOG EcoTrafiX platform enabling predictive and proactive transportation management on a regional scale.

As technology rapidly evolves and policy landscapes continue to shift, connected vehicle technology must address both near and long-term viability of solutions and services. DSRC and C-V2X provide safety and mobility communications today, while preparing the corridor for advancements tomorrow. This infrastructure, coupled with

a technology-neutral corridor management central system, will position NCTCOG to benefit from long-term safety and mobility operations. The Kapsch solution meets those short- and long-term needs.

The Kapsch solution suite is technology-agnostic, interfacing with minimal development to the various platforms and existing technologies of our partner agencies. At the heart of our ecosystem is the Connected Mobility Platform (CMP) and its accompanying Connected Mobility Control Centre (CMCC). These systems bridge traditional intelligent transportation systems (ITS) and services with CV services, data services, partner systems, traveller information services and Mobility on Demand (MOD) services. Through this ecosystem, Kapsch weaves a migration path from today's static data-driven solutions to tomorrow's dynamic data-driven solutions. The Kapsch delivers tomorrow's promise today by connecting infrastructure with in-vehicle camera sourced data. This connected and automated vehicle (CAV) data is unique in that data is pushed directly from these connected vehicles. The system can deliver both historical CAV traffic intelligence and real-time data to partners to accommodate a broad variety of use cases.

The Kapsch architecture is fundamentally a three layer pyramid. The foundation is the Data and Insight layer. This layer provides all source data such as CV data, traditional ITS sensor data, and other data input into the system. Analytics is conducted which provide insight into the operational layer. The Operational layer includes systems such as ATMS, and in the case of NCTCOG, EcoTrafiX. At this point, data is operationalized for traffic management. The final layer is the Action layer. The Action layer consists of the business rules and operations staff responsible for determining course of action presented by the Operational layer.

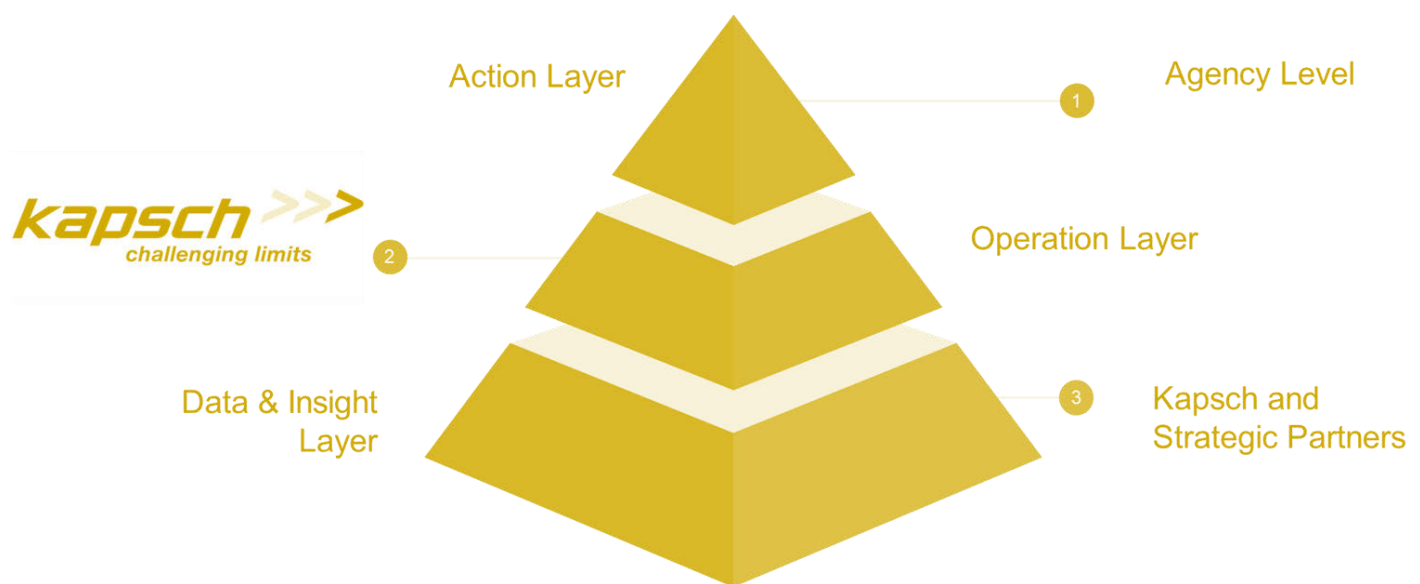

Figure 1 Three Layer Architecture Pyramid

FROM TRAFFIC MANAGEMENT TO NETWORK OPTIMIZATION

Some would say that “data is data”. While there are common principles of data management which apply broadly across most domains, optimizing the value of a data platform depends on the specific applications and use cases that are to be built on top of it. The Kapsch team is uniquely distinguished in the breadth and depth of its expertise in transportation applications, and the team’s data platform is purpose built to serve those applications now and in the future.

One such application is real-time operations of the surface transportation network. Advanced traffic management systems (ATMS) have undergone a progression from device management tools to event and flow management systems. The next generation of ATMS will need to tackle the far more challenging problem of network optimization.

As we ask more and more of our physical infrastructure we must do a better job of matching demand to all available capacity within the network. This means either moving the demand to meet the capacity or moving the capacity to meet the demand. It is possible to increase or move capacity with existing tools by opening hard shoulders, adjusting ramp meters, etc., and it is possible to move demand by changing detour routes, incentivization or other travel demand management strategies. What we lack are systems capable of determining optimal adjustments in real-time at a regional scale. The Kapsch data platform will provide the foundation for the next generation of traffic management solutions. The platform will deliver the speed and scale of data processing necessary to make fine-grained operational adjustments which will maximize the capacity of our existing physical infrastructure.

The ATMS of the near future will provide semi or fully automated decision support systems to help operators match demand and capacity in real time. The modelling and simulation tools necessary to support such systems exist today, but these are very data hungry tools. The primary obstacle for real-time network optimization systems is a lack of quality data. A true network optimization system presents extremely demanding requirements for data coverage, accuracy and timeliness. Traditional traffic data collection methods are not sufficient. The data platform is ready for deployment today but is also the foundation of traffic management systems for the future.

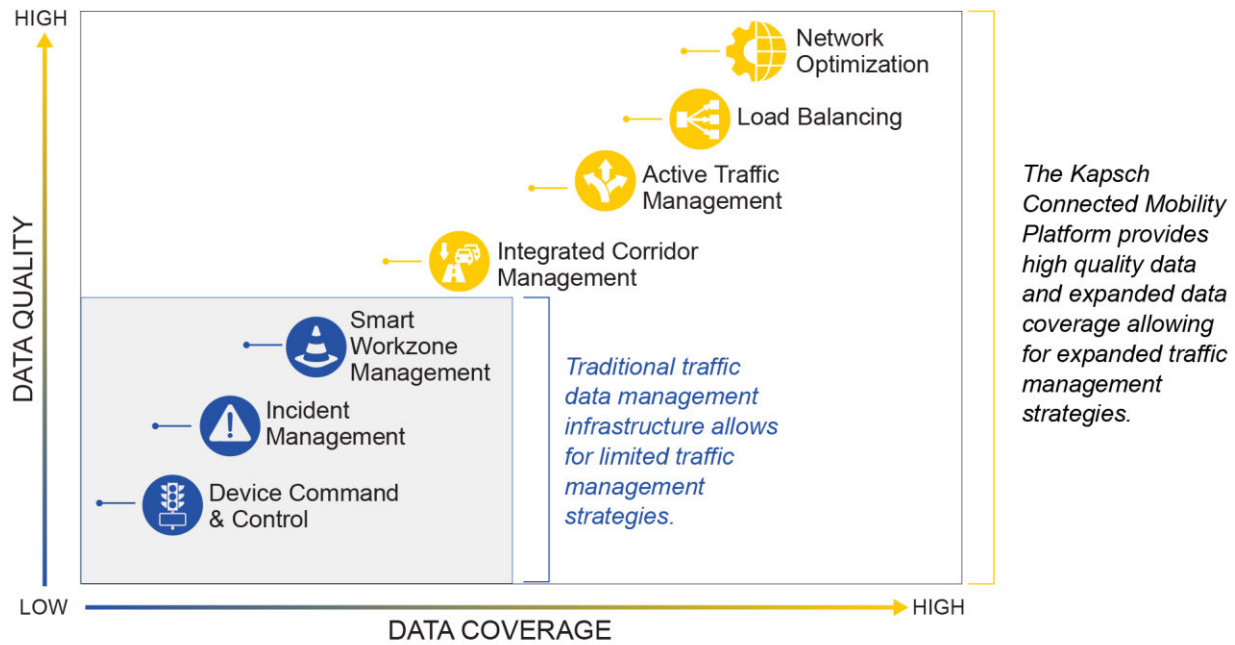

018.TXATCMD20

Figure 2 Traditional Traffic Management Strategies vs. expanded Traffic Management Strategies possible on the Connected Mobility Platform

4. TRANSPORTATION SYSTEMS AND SERVICES

A description of transportation systems and services to be included in the project.

The Kapsch system can support a suite of CV services. A few examples follow which in our estimation provide the most immediate impact to NCTCOG and motorists in its 16-county region. Foundational messaging enables the following functionality. By enabling traveller information messaging, static or dynamic data can be sent to the roadside allowing critical message flow to roadway users. While full ATMS functionality and integration may be ideal, Kapsch’s CMCC and CMP enables the functionality described below.

- **Virtual Road Signs.** The CMP defines virtual road signs that are associated with one or more RSUs. Sending a message to a Virtual Road Sign will result in SAE J2735 TIM messages being sent to the appropriate RSUs for display via OBUs. Virtual signs are the foundational messaging process to deliver information to the corridor. An example generic process can be found in figure 2, where with VRS is displayed.
- **Slow Speed Ahead.** The virtual road signs can be configured with baseline messages that indicate where drivers should be alerted of areas where slower speeds are advised. The CMP can be configured to automatically send pre-configured Virtual Sign Messages when roadway events are detected without interaction from an external ATMS.
- **CV Data Storage.** CMP stores all BSM messages received at the corridor RSUs. Further definition regarding further processing of BSM data for ATMS integration and predictive operations as examples. Initially, the CMP shall only collect and

store raw BSM data. Before fully describing these use cases, the following sample list provides the scale of use cases available.

- **Roadway Event Detection.** The CMP supports the detection of the following roadway events:
 - **Mayday Alerts** coming from vehicles sending SAE J2735 BSM or other data types
 - **Wrong Way Driver Detection** via CV data or integration with roadside sensors
 - **Vulnerable Road User Detection** via SAE J2735 BSM or other connected data systems reporting vehicles with zero speed (stopped)
 - **Detected roadway events** are also routed to the ATMS for ITS level incident/event management
 - **Connected Maintenance Vehicles** (custom): The CMP supports the receipt of roadway maintenance messages (MX) from connected maintenance vehicles and routes them to the appropriate agency
 - **Road Works Warning** information is delivered to the corridor in specific work zone warnings to inform drivers of active work zones; a sample generic process is depicted in figure 3, where the driver warning is displayed.

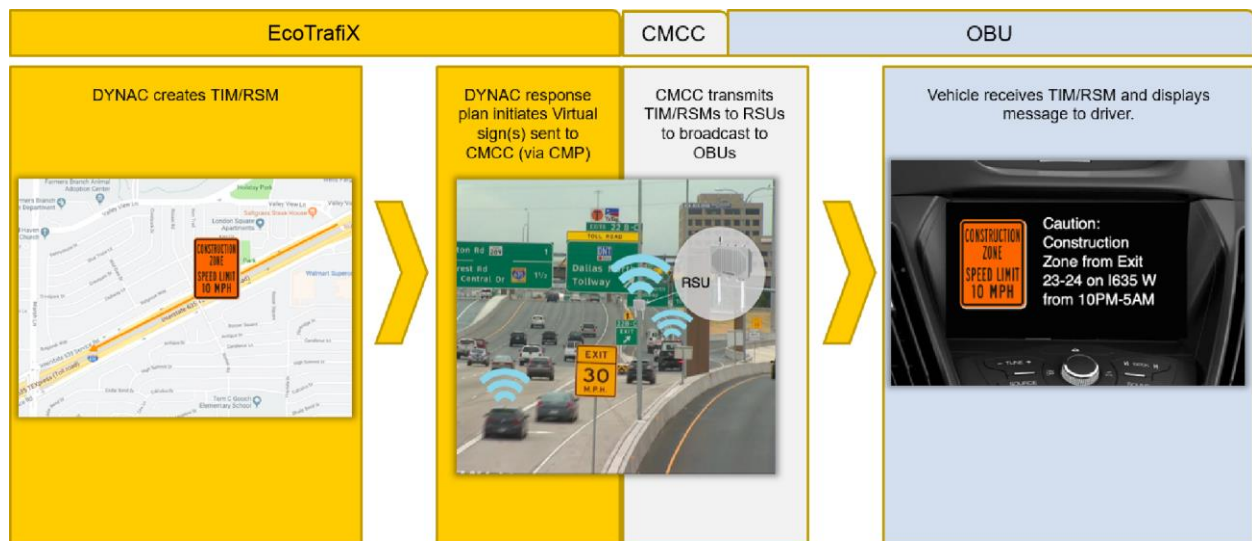

003.TXATCMTD20

Figure 3. Road Works Warning

- **Lane Mapping.** A geospatial-centric user interface supports the intersection and roadway section lane configurations. The CMP will send SAE J2735 MAP messages to each RSU to establish a baseline lane mapping configuration as well as additional MAP messages if the lane availability changes due to roadway events or maintenance.

AUTOMATED INCIDENT DETECTION

Automated incident detection, depicted in figure 4, combines multiple data sources to efficiently identify hazardous conditions occurring in the corridor. Such use cases include but are not limited to Vulnerable Road User Warning, Wrong Way Driver Warning, Debris in Roadway Warning and End-of-Queue Warning. Each use case, although identifying a unique scenario, generate alerts in a similar fashion. Each scenario may be sensed through either a singular sensor or combination of sensors that are monitored by the Kapsch CMP. Loops in the pavement, CCTV cameras, and connected data all provide key indicators which CMP collects, analyses and proactively identifies as an event which meets criteria of the use case above.

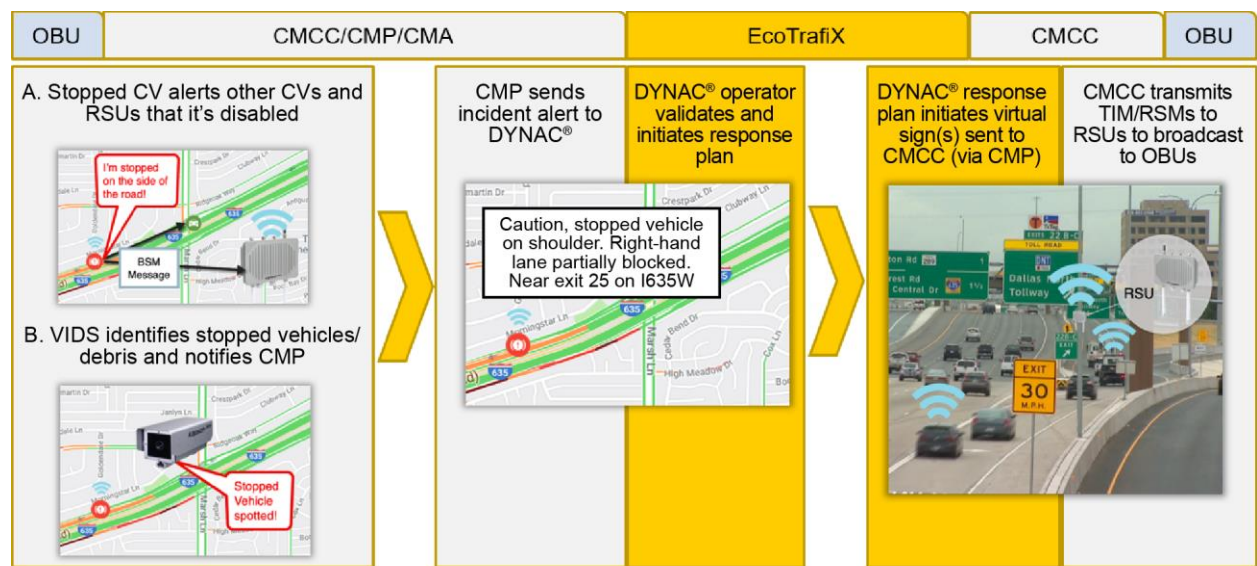

004.TXATCMTD20

Figure 4. Automated Incident Detection

In the case of End-of-Queue Warning, a vehicle equipped with a V2X OBU automatically detects slowdown or hard braking due to an incident, work zone, etc. from other vehicles. The OBU sends BSM, including location and heading information, to the RSU and then transmitted to the CMP. In parallel, slowdowns are detected by Kapsch's Deep Learning Versatile Platform (DLVP) Video Incident Detection System (VIDS). A sample processed image from the DLVP may be seen in Figure 5 below. VIDS detects vehicle slowdowns and creates BSM on behalf of the vehicle. The BSM is transmitted to CMP. Kapsch's EcoTrafiX, receives information from CMP and initiates the response plan. CVs approaching the stopped vehicle or debris are alerted using the virtual signs use case process. Non-equipped vehicles are alerted using traditional ITS devices, such as dynamic messaging signs (DMS).

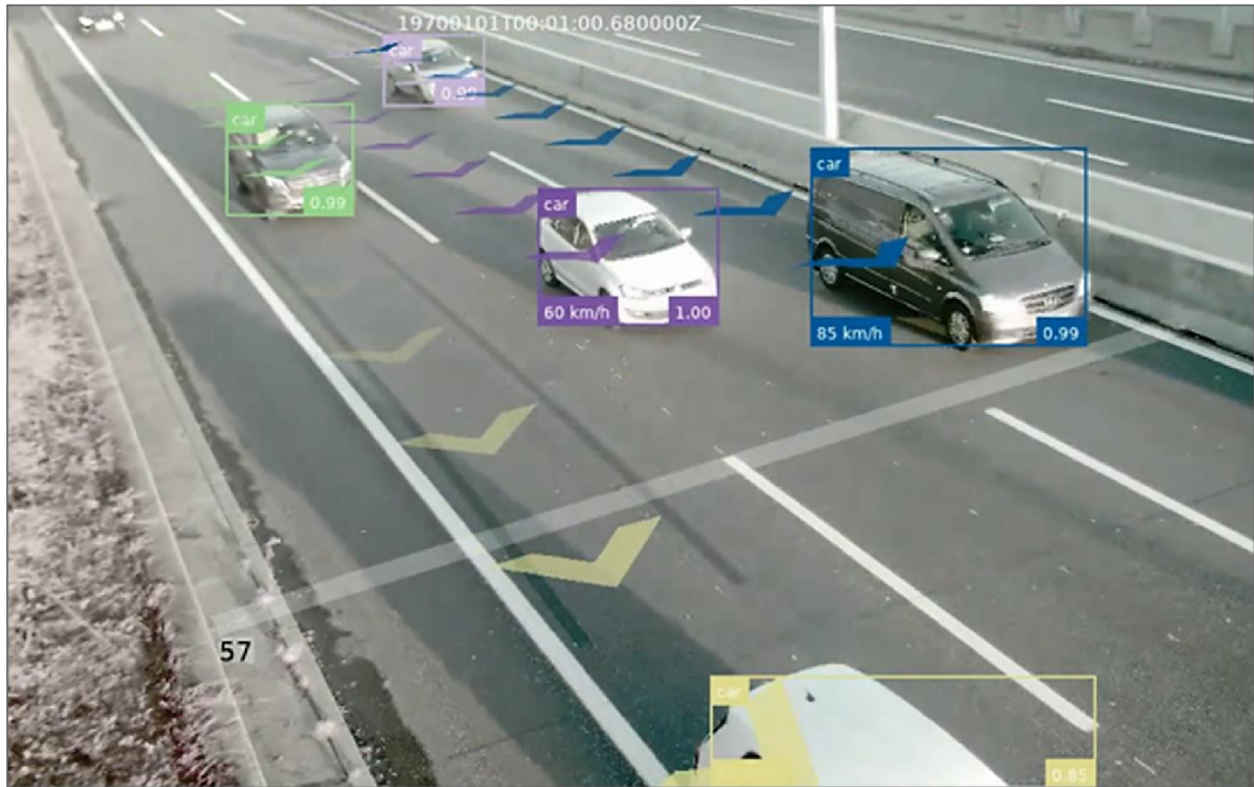

005.TXATCMD20

Figure 5 DLVP System Object Detection

COMMERCIAL VEHICLE V2X INITIATIVES

V2X initiatives for commercial vehicles can have a profound effect on safety for both in-state and out-of-state carriers. Partnering with the motor carrier community and trucking associations will provide solutions to benefit Texas and neighbouring states.

V2X HAZMAT TRACKING

Trucks carrying hazardous materials (Hazmat), such as gas tankers present a safety issue for hazmat carriers.

OBU's could be provided to approved carriers to allow the transportation of Hazmat materials through the tunnel. The CMCC could provide real-time carrier/location information, types of Hazmat, push weather or traffic conditions to the driver, and provide statistics for state validation and tracking.

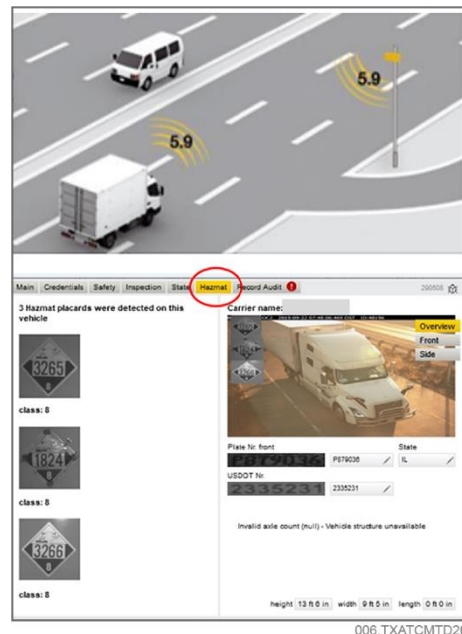

006.TXATCMD20

Figure 6A. Hazmat Detection

Hazmat placard readers could be stationed prior to the tunnel to detect Hazmat violations, those carriers not enrolled. This full-service system would track approved

Hazmat carries, provide timely weather and traffic information to the carrier, and detect potential violations of Hazmat loads.

COMMERCIAL VEHICLES – VIRTUAL WEIGH STATION

Road operators today are challenged by the potential road damage, safety hazards, and environmental issues created by noncompliant trucks and unsafe drivers. Limited enforcement resources are causing authorities to rethink strategies, including the deployment of innovative technologies that improve enforcement efficiency and effectiveness. Empowering enforcement officers with advanced technology can have a profound



007.TXATCMTD20

effect on public safety, highway preservation, homeland security, and revenue capture that is owed to state and local authorities. Many of the tasks necessary to ensure compliance, such as the weighing of trucks, are repetitive and can be automated in order to free enforcement officers to focus on the higher-value activities that necessitate the use of their extensive training and judgment.

Kapsch Virtual Commercial Vehicle Enforcement (VCVE) consists of robust and modular systems to support the dynamic needs of state enforcement agencies. Whether for mainline or in-station, remote or mobile, Kapsch VCVE delivers high-performing solutions for customer needs.

VCVE addresses the requirements for credentials, weight, and safety enforcement of commercial vehicles to ensure compliance with laws and regulations. VCVE comprises a set of roadside sensors and back-end systems to capture commercial vehicle information such as license plate numbers, US DOT numbers, Hazmat placards, and vehicle height and weight characteristics. The system then checks the collected data against third party databases, such as permitting systems and federal carrier registration/safety databases. Data, including flags for potential discrepancies, is then routed to the responsible enforcement agency through the web-based Kapsch Enforcement Back Office (EBO) for immediate action or processed through the Kapsch commercial back office (CBO) for post enforcement actions. The VCVE process flow is custom-tailored to the agency's needs, from providing subsystem data to a complete end-2-end system and service for customer billing and relationship management.

CONNECTED MOBILITY CONTROL CENTER (CMCC)

The Kapsch Connected Mobility Control Centre is the key component in operating and managing a CV corridor. With the CMCC, an operator can see what is happening within the network in real time. Operators are notified immediately if a device has an issue or stops communicating. Configuration changes can be made and recorded and are automatically distributed to the appropriate devices. Messages such as mapData (MAP) and traveller information messages (TIM) can be configured online and then automatically sent to appropriate devices. External applications can receive and send data to various devices in the system thus allowing extensions to the functionality of the overall system without expensive changes to embedded software. With CMCC, operators have insight into what is happening in the CV corridor.

Kapsch's CMCC provides a highly robust and advanced system for managing the connected transportation assets used in smart corridors and smart cities. ***The CMCC is a web-based solution with technically robust and flexible architecture, allowing a variety of external connections and configurations.***

CMCC is delivered as a hosted cloud-based solution, allowing access to the system from wherever needed. Kapsch hosts the solution using a Microsoft Azure facility, which gives us access to all the state-of-the-art security features built into the system. Though we recommend Azure for its reliable storage capabilities, the solution can be deployed in any cloud environment.

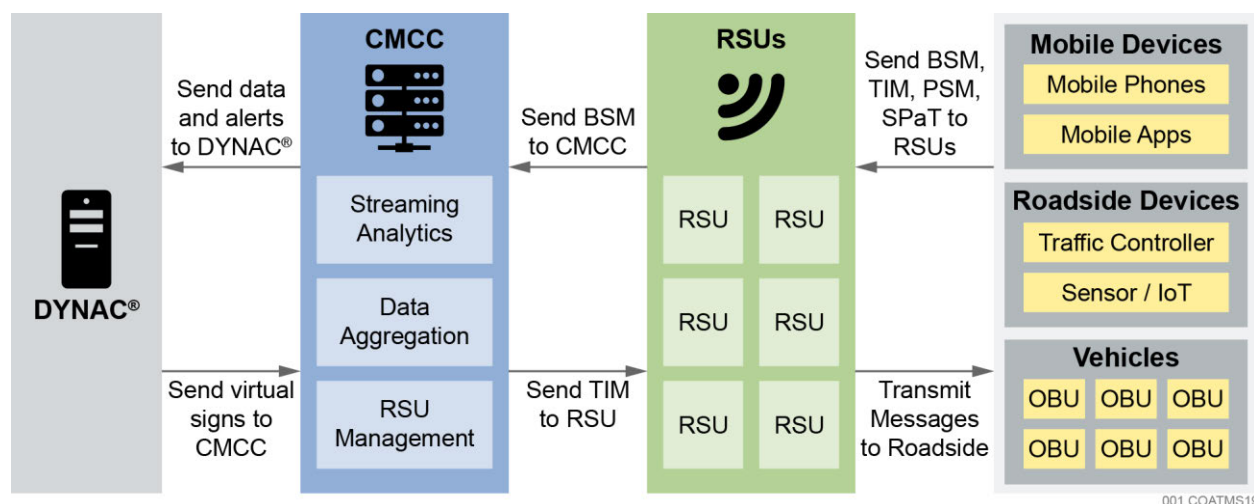

Figure 6B. Data Flow Between DYNAC and CMCC CV Systems

CMCC includes the ability to build map messages via an intuitive GUI. When integrated with an advanced traffic management solution, operators can create and distribute virtual sign messages and take advantage of data being generated by connected vehicles. Figure 6C provides an example of the detection flow for a wrong-way driver scenario.

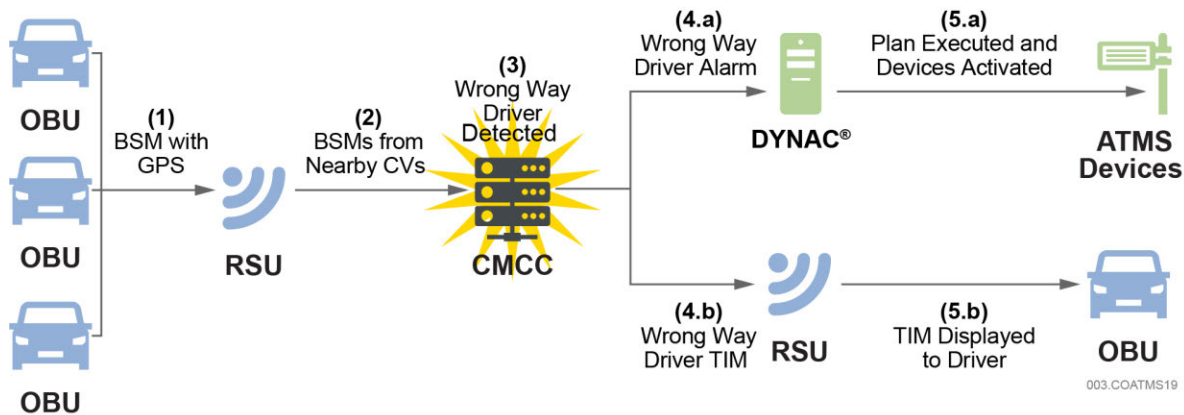

Figure 6C. Wrong-Way Driver Detection Flow

Kapsch’s CMCC provides a highly robust and advanced system for managing the connected transportation assets used in a smart city. The CMCC is a Web-based solution with architecture that is technically robust and flexible, allowing a variety of external connections and configurations.

CMCC FUNCTIONALITY

- **Automated Monitoring and Alerts.** Dashboards and statuses provide the ability to monitor all devices within the network to detect any issues in connectivity or messaging. Users can register for alerts and notifications when issues arise with equipment, system functions or recorded data. Figure 7, shows the map-based view which allows for instant monitoring of the locations in the CV network.

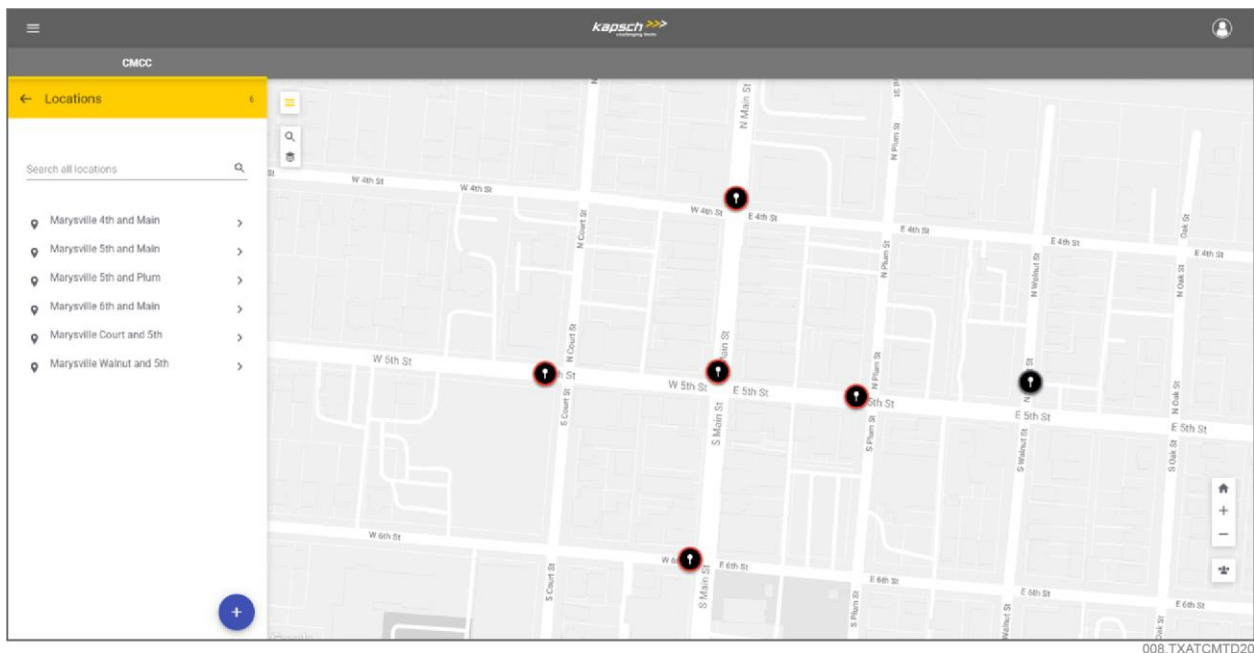

Figure 7 CMCC Automated Monitoring and Results

- **Asset Management.** Each location and its associated equipment can be defined and information on it maintained. Most configurations are set at the location level, rather than the device level. This allows equipment to be swapped out quickly and easily with minimal setup required.
- **Automated Device Configuration.** CMCC provides fast, easy device setup. Once all configurations are set, RSUs can be swapped out quickly and easily with minimal re-configuration required.
- **Advanced Message Configuration and Scheduling.** CMCC extends basic RSU messaging functionality by providing robust scheduling capabilities. This includes the ability to set specific times, days of the week and intervals in which messages should be transmitted. Configurations are granular enough to allow special messages to be sent only on specific dates or during specific times of day; for example, it can accommodate messages that only repeat July 4 from 5:00pm to midnight. Updated messages and message scheduling are applied immediately.
- **MAP Message Builder.** CMCC includes the ability to build MAP messages quickly and easily via an intuitive graphical user interface format directly on a map view of the intersection or road segment. Figure 8 shows a sample screen of the CMCC Map Builder from this you can see the various segments that make up each of the ingress and egress lanes of the intersection.

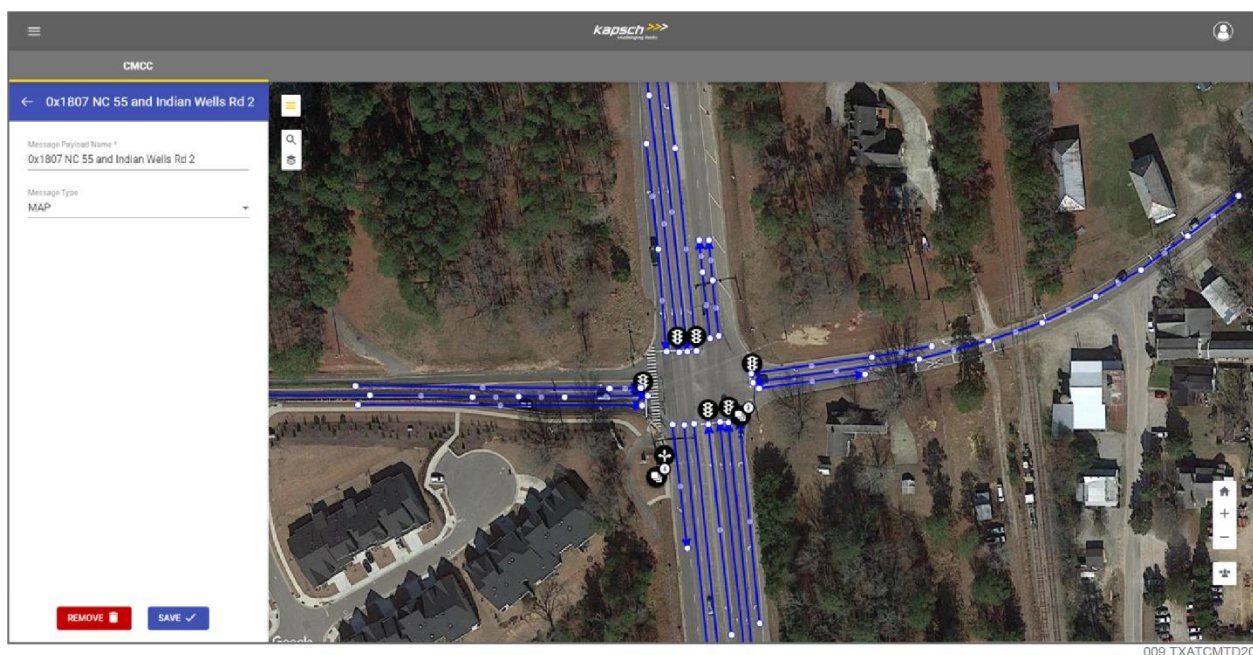

Figure 8. CMCC Map Message Builder

- **TIM and RSM Message Generation.** CMCC includes functionality for building and distributing Roadside Safety (RSM) and Traveller Information (TIM) messages, including information broadcast on fixed and dynamic signs and other information communicated to the driver.
- **Live Data Monitoring.** Real-time traffic information can be monitored at any location. This includes traffic signal phasing and all communication between RSUs, OBUs, and pedestrians. Dashboards and statuses provide the ability to monitor all

devices within the network to determine if there are any issues in connectivity or messaging. Figure 9 shows a sample of live-data monitoring which includes lights, map data and vehicles surrounding the roadside unit.

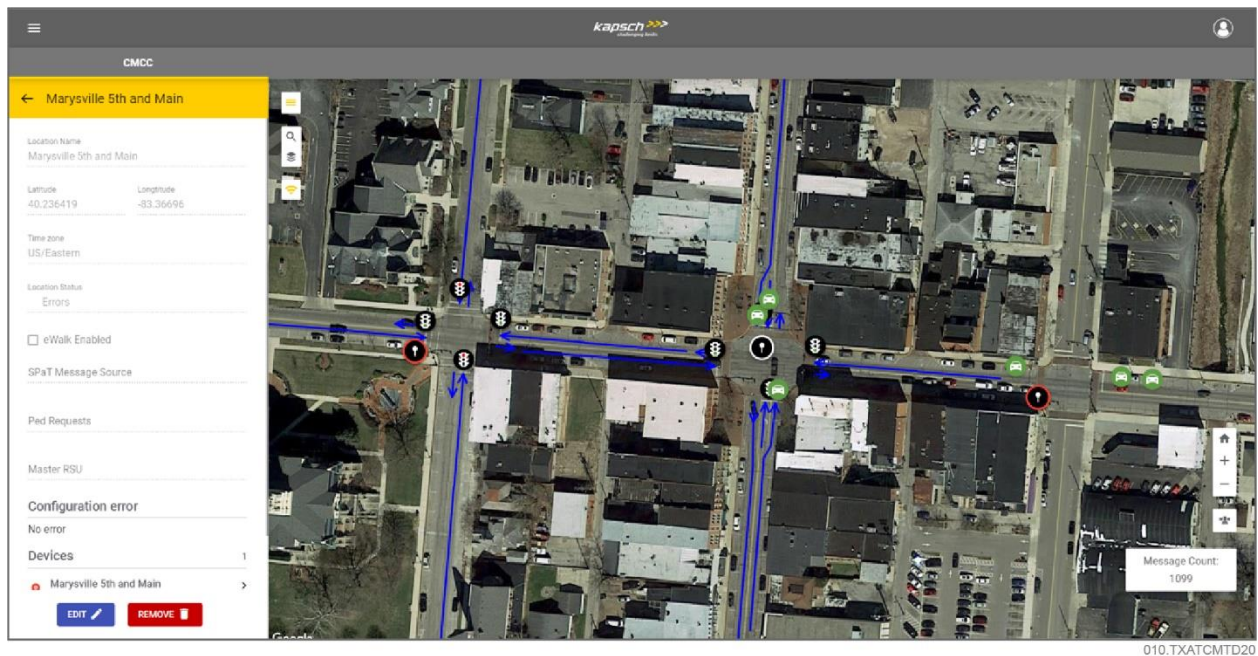

Figure 9. Live Data Monitoring

- **Data Management.** Real-time traffic information can be monitored at any location, including traffic signal phasing and all communication between RSUs, OBUs, and pedestrians.

REFERENCES – CURRENT WORK (AUSTRALIA)

Project Name: Kapsch - Smart Intersection in AIMES (Melbourne, Victoria)

Dates: Early 2020 to Early 2021 (ongoing)

Scope of work:

- Description of use case focus areas below on intersection of Victoria Parade and Nicholson Street., Melbourne within the AIMES environment.
- Situational awareness through utilisation of sensors to achieve load balancing of the network, to prioritise and demand manage a corridor including surrounding intersections at a micro level; small portion of a road network.
- Focus to enhanced areas of situational awareness including the below featured use cases currently in-progress
 - **Yellow box detection** through our Kapsch ANPR camera to detect a vehicle i
 - **Protected turn** - detecting near miss analytic data to review change strategies to improve intersections safety
 - **Erratic driving detection** through the Kapsch Deep Learning Versatile Platform (DLVP) to detect 'near misses' such as erratic lane changing, crossing solid lines or proximately to vulnerable road users
 - **Pedestrian Jaywalking detection.** Kapsch DLVP detects pedestrians in intersections to alert drivers – future development within V2X connected vehicle technology to translate this into Basic Safety Messages (BSMs) to send to compatible vehicles in real-time.
 - **Speed Analytics** including vehicle counting, make, classification. Kapsch DLVP system in real-time provides a rich data stream of vehicle classification average speed and counting of vehicles (to replace in-road loop sensors.)
 - **Bus Lane Enforcement** Kapsch ANPR system to enforce bus lanes and provide alert to drivers using the lane inappropriately by using the Kapsch DLVP system to classify the vehicle between car (OK) and other vehicles (not OK).

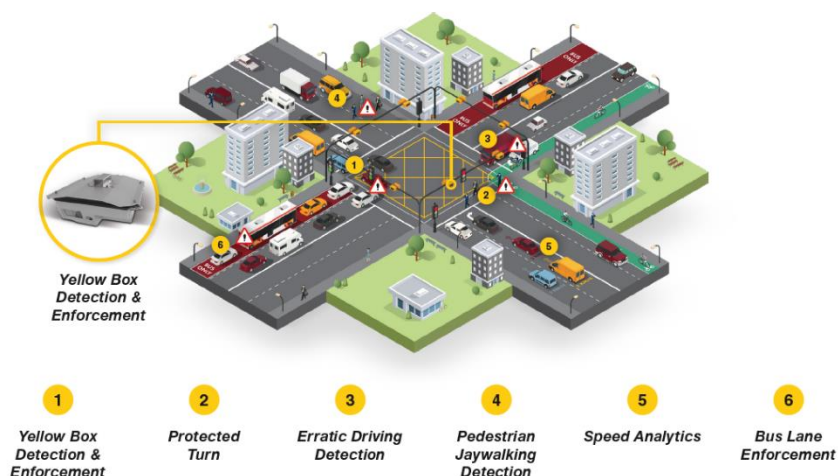

Project Name: Kapsch - Intelligent Corridor in AIMES (Melbourne, Victoria)
Dates: 2020 to 2022

Scope of work:

- Description of use case focus areas below on Nicholson Street, Melbourne within the AIMES environment. High innovation 'managed urban corridor' testbed in Australia.
- Situational awareness through utilisation of sensors to achieve load balancing of the network, to prioritise and demand manage a corridor including surrounding intersections at a micro level; small portion of a road network.
- Future deployment of Kapsch's Connected Mobility Platform (CMP) for data fusion of various roside devices to increase quality of data and make better, more information decision upon.
- Focus to different user perspectives and layers of information (weather, traffic, delays, travel time, etc)
- Future implementation of response plans to 'load balance' the network and understand prediction models of likely behavior from suggested executed changes

Kapsch Intelligent Corridor

