

Case Details

<i>Case Number</i>	87 - H046	<i>Calculation type</i>	2.3
<i>Date of Accident</i>	Tuesday, October	<i>Time</i>	5 pm
<i>Speed Limit</i>	60 km/hr	<i>Number of Pedestrians Involved</i>	1
<i>Travel Speed</i>	64 km/hr	<i>Travel Speed Source</i>	Momentum Calculation
<i>Impact Speed</i>	64 km/hr	<i>Impact Speed Source</i>	Momentum calculation

Pedestrian Details

<i>Fatal</i>	Yes
<i>Age</i>	80
<i>Sex</i>	Female
<i>BAC Pedestrian</i>	0 %
<i>Action</i>	Walking
<i>Movement</i>	Crossing the road
<i>Side Impacted</i>	Unknown

Driver Details

<i>Age</i>	28
<i>Sex</i>	Male
<i>BAC Driver</i>	0.065 %
<i>Driving Experience</i>	12 years
<i>Licence Type</i>	Full
<i>Driver Action</i>	Swerved, did not brake

Impact Vehicle Details

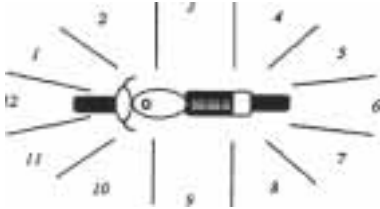
<i>Vehicle Model</i>	1979 Honda 500cc Trail bike	
<i>Type</i>	Motorcycle	
<i>Number Involved</i>	1	
<i>Modifications</i>	None	

Road Site Details

<i>Traffic Control</i>	None	<i>Road Type</i>	Arterial
<i>Traffic Conditions</i>	Moderate	<i>Road Alignment</i>	Straight
<i>Weather Conditions</i>	Fine, dry road	<i>Natural Lighting</i>	Day
<i>Number of Lanes</i>	1	<i>Street Lighting</i>	Not applicable
<i>Road Division</i>	Centre line		

Reduced Travel Speed Analysis

	5 km/hr reduction	10 km/hr reduction	10% reduction	20% reduction
Travel Speed (km/hr)	59	54	58	51
Impact Speed (km/hr)	59	54	58	51

Site Diagram 87 - H046

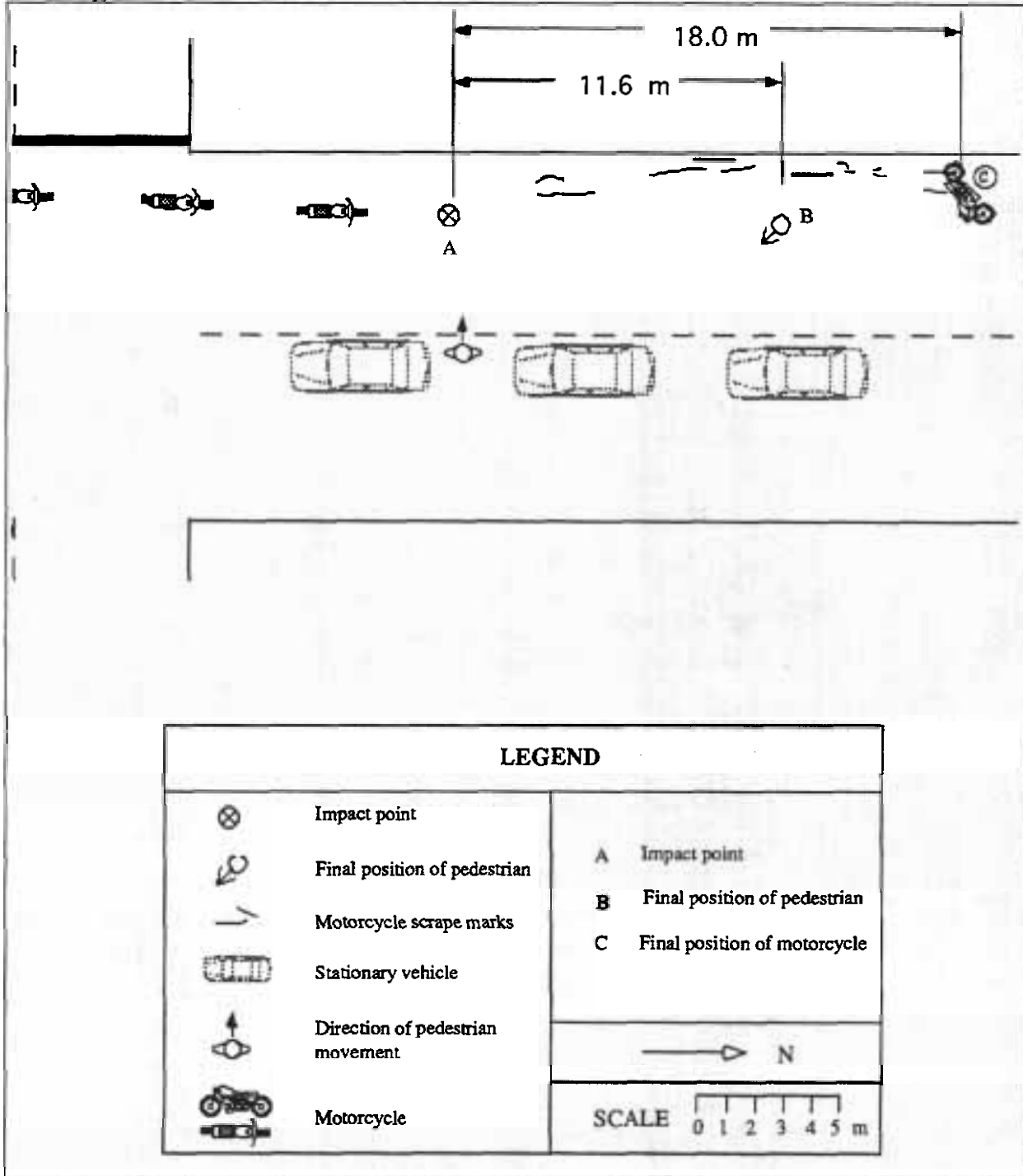

Accident Description

The motorcycle was travelling in a northerly direction at about 64 km/hr. The pedestrian was crossing the road from east to west and had walked through stationary cars travelling south and stopped on the centre line. She waited there for some cars to pass then walked quickly across the western lane. The rider of the motorcycle did not see the pedestrian until just before the impact when he tried to avoid a collision by swerving to the left. This was to no avail and the collision occurred at point A. The pedestrian was struck on her left side by the centre front of the motorcycle and was thrown forward along the road coming to rest at point B. The rider and motorcycle slid along the road and stopped at point C.

Case Details

<i>Case Number</i>	87 - H051	<i>Calculation type</i>	2.1
<i>Date of Accident</i>	Friday, November	<i>Time</i>	9 pm
<i>Speed Limit</i>	60 km/hr	<i>Number of Pedestrians Involved</i>	1
<i>Travel Speed</i>	72 km/hr	<i>Travel Speed Source</i>	Skid marks
<i>Impact Speed</i>	60 km/hr	<i>Impact Speed Source</i>	Skid marks

Pedestrian Details

<i>Fatal</i>	Yes
<i>Age</i>	17
<i>Sex</i>	Female
<i>BAC Pedestrian</i>	0 %
<i>Action</i>	Walking
<i>Movement</i>	Crossing the road
<i>Side Impacted</i>	Left side to vehicle

Driver Details

<i>Age</i>	20
<i>Sex</i>	Male
<i>BAC Driver</i>	0.213 %
<i>Driving Experience</i>	2 years
<i>Licence Type</i>	Disqualified
<i>Driver Action</i>	Braked before impact

Impact Vehicle Details

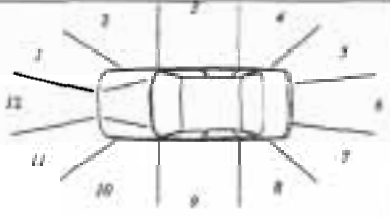
<i>Vehicle Model</i>	1978 Ford Cortina sedan	
<i>Type</i>	Car	
<i>Impact Point</i>	12	
<i>Number Involved</i>	1	
<i>Modifications</i>	None	

Road Site Details

<i>Traffic Control</i>	Traffic signal at intersection	<i>Road Type</i>	Arterial
<i>Traffic Conditions</i>	Light	<i>Road Alignment</i>	Straight
<i>Weather Conditions</i>	Fine, dry road	<i>Natural Lighting</i>	Night
<i>Number of Lanes</i>	2	<i>Street Lighting</i>	Street lights
<i>Road Division</i>	Centre line		

Reduced Travel Speed Analysis

	5 km/hr reduction	10 km/hr reduction	10% reduction	20% reduction
Travel Speed (km/hr)	67	62	65	58
Impact Speed (km/hr)	50	37	44	19

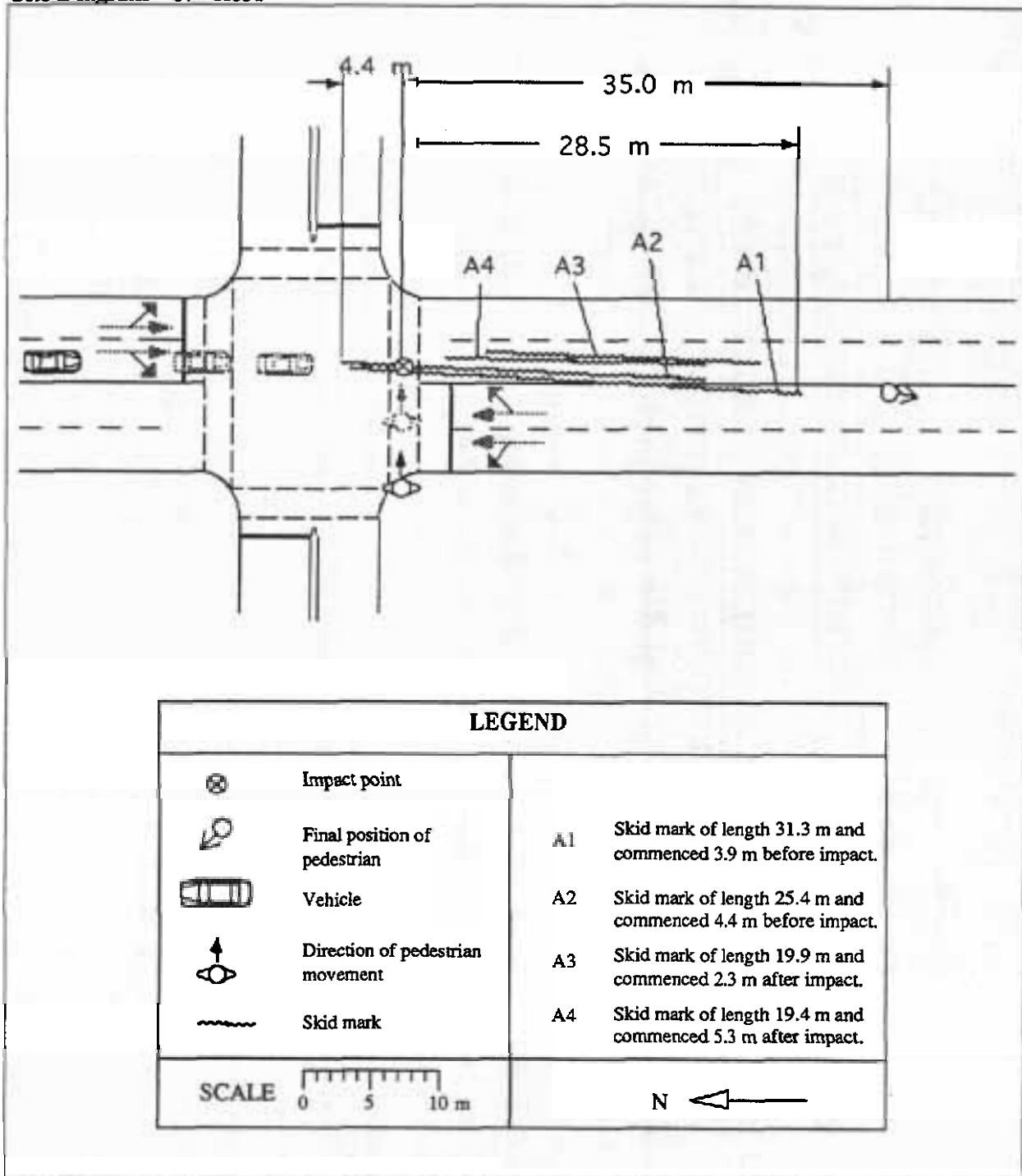

Accident Description

The car was travelling south and collided with a pedestrian who was crossing the road at a pedestrian crossing in an easterly direction. The pedestrian was crossing against the "DON'T WALK" lights. The driver stated that he was travelling at about 72 km/hr and saw the pedestrian only seconds before impact. The driver also stated that he braked before impact. The traffic lights at the intersection at that time were green for south and north bound traffic. There were three witness to the crash. The first witness, who was standing at the pedestrian crossing, estimated the vehicle's speed to be around 100 to 120 km/hr and said that the vehicle did not brake to a complete stop. The second witness, who was driving about 20 metres in front of the vehicle at a speed about 50 km/hr stated that the vehicle speed's was about 70 to 80 and it braked to 10 to 15 km/hr before speeding away. The third witness stated that the vehicle skidded to a complete stop for a couple of seconds before speeding away. The pedestrian was hit on her left side by the centre front of the vehicle.

Case Details

<i>Case Number</i>	87 - H053	<i>Calculation type</i>	2.1
<i>Date of Accident</i>	Monday, November	<i>Time</i>	9 pm
<i>Speed Limit</i>	60 km/hr	<i>Number of Pedestrians Involved</i>	1
<i>Travel Speed</i>	60 km/hr	<i>Travel Speed Source</i>	Skid marks
<i>Impact Speed</i>	60 km/hr	<i>Impact Speed Source</i>	Skid marks

Pedestrian Details

<i>Fatal</i>	Yes
<i>Age</i>	54
<i>Sex</i>	Male
<i>BAC Pedestrian</i>	0 %
<i>Action</i>	Running
<i>Movement</i>	Crossing the road
<i>Side Impacted</i>	Left side to vehicle

Driver Details

<i>Age</i>	21
<i>Sex</i>	Female
<i>BAC Driver</i>	0.425 %
<i>Driving Experience</i>	Unknown
<i>Licence Type</i>	None
<i>Driver Action</i>	Braked after impact

Impact Vehicle Details

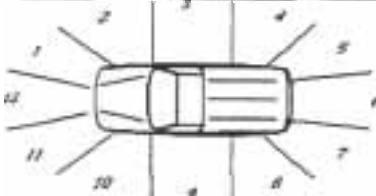
<i>Vehicle Model</i>	1964 Holden station wagon	
<i>Type</i>	Car derivative	
<i>Number Involved</i>	1	
<i>Modifications</i>	None	

Road Site Details

<i>Traffic Control</i>	None	<i>Road Type</i>	Arterial
<i>Traffic Conditions</i>	Moderate	<i>Road Alignment</i>	Straight
<i>Weather Conditions</i>	Fine, wet road	<i>Natural Lighting</i>	Night
<i>Number of Lanes</i>	3	<i>Street Lighting</i>	Street lights
<i>Road Division</i>	Raised median strip		

Reduced Travel Speed Analysis

	5 km/hr reduction	10 km/hr reduction	10% reduction	20% reduction
Travel Speed (km/hr)	55	50	54	48
Impact Speed (km/hr)	55	50	54	42

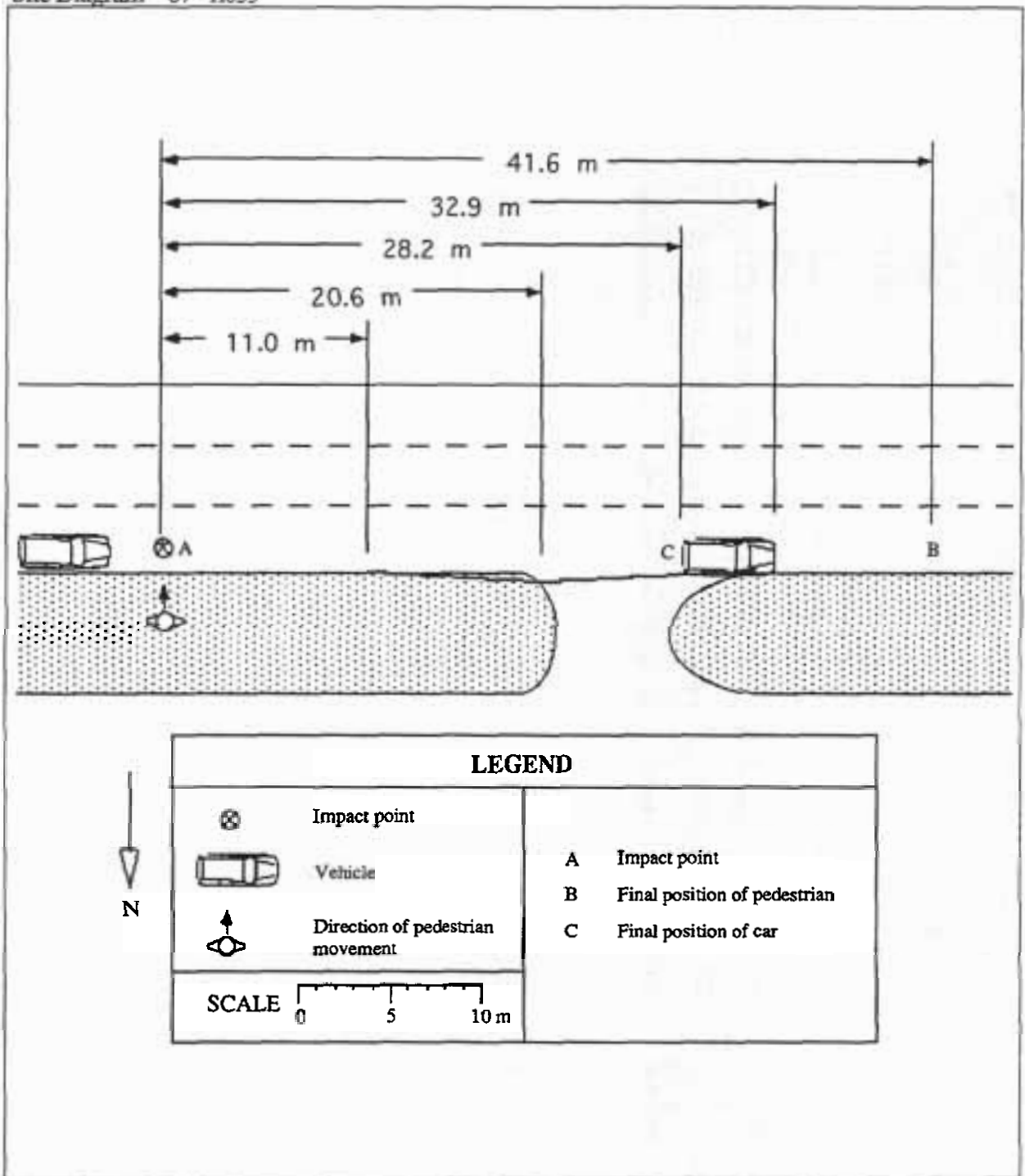

Accident Description

The vehicle was travelling in a westerly direction at about 60 km/hr. The pedestrian was running across the road from north to south and appeared to be trying to beat the traffic. The driver had just passed through an intersection where the lights had just turned green. The speed of the vehicle was verified by a following driver as they did not need to slow for the red light. The driver of vehicle 1 stated that she saw the pedestrian about 1 metre in front of her vehicle and could not remember taking any evasive action. The driver of the following vehicle stated that he saw the brake lights come on as the car swerved onto the median strip after the impact, and then the car return to the road stopping a short distance later. The collision occurred at point A with the pedestrian being struck on his left side. He was hit by the front of the bonnet just right of centre, then rolled up impacting his head on the plenum and was thrown forward coming to rest at point B. The car stopped at point C.

Case Details

<i>Case Number</i>	88 - H003	<i>Calculation type</i>	4.1
<i>Date of Accident</i>	Sunday, February	<i>Time</i>	1 am
<i>Speed Limit</i>	60 km/hr	<i>Number of Pedestrians Involved</i>	1
<i>Travel Speed</i>	60 km/hr	<i>Travel Speed Source</i>	Driver
<i>Impact Speed</i>	60 km/hr	<i>Impact Speed Source</i>	Projection distance

Pedestrian Details

<i>Fatal</i>	Yes
<i>Age</i>	17
<i>Sex</i>	Female
<i>BAC Pedestrian</i>	0.136 %
<i>Action</i>	Walking
<i>Movement</i>	Along the road
<i>Side Impacted</i>	Back to vehicle

Driver Details

<i>Age</i>	36
<i>Sex</i>	Male
<i>BAC Driver</i>	0.16 %
<i>Driving Experience</i>	18 years
<i>Licence Type</i>	Full
<i>Driver Action</i>	Braked before impact

Impact Vehicle Details

<i>Vehicle Model</i>	1981 Mitsubishi Sigma	<i>Impact Point</i>	1
<i>Type</i>	Car		
<i>Number Involved</i>	1		
<i>Modifications</i>	None		

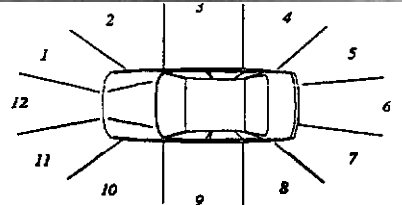

Road Site Details

<i>Traffic Control</i>	None	<i>Road Type</i>	Arterial
<i>Traffic Conditions</i>	Light	<i>Road Alignment</i>	Straight
<i>Weather Conditions</i>	Raining	<i>Natural Lighting</i>	Night
<i>Number of Lanes</i>	3	<i>Street Lighting</i>	Street lights
<i>Road Division</i>	Raised median strip		

Reduced Travel Speed Analysis

	5 km/hr reduction	10 km/hr reduction	10% reduction	20% reduction
Travel Speed (km/hr)	55	50	54	48
Impact Speed (km/hr)	43	13	39	0

ite Diagram 88 - H003

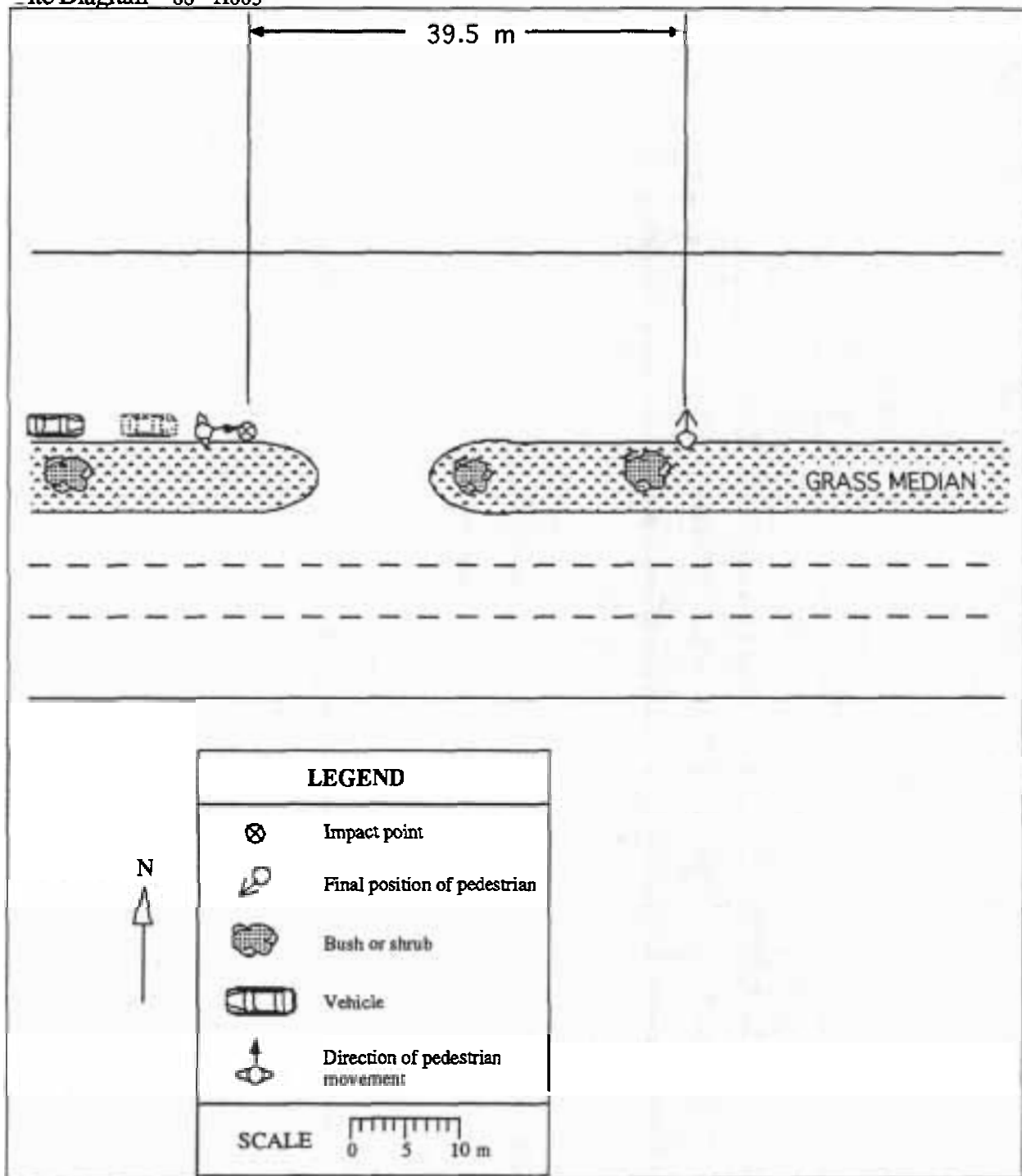

Accident Description

The car was travelling east and collided with a pedestrian crossing the road diagonally in a northerly direction. The driver stated that he was driving near the median strip at about 60 km/hr when he saw the pedestrian about 5 metres in front of him and about one and a half metres off the median strip walking in a easterly direction. He applied his brakes before colliding with the pedestrian. A witness who was following behind the driver stated that the driver was travelling about 60 km/hr and did not appear to take any evasive action at that time. The pedestrian was hit on her back by the front left of the vehicle. The road was normally a three lane road for east bound traffic but it was not marked with lane lines at the time of the accident.

Case Details

<i>Case Number</i>	88 - H006	<i>Calculation type</i>	3.1
<i>Date of Accident</i>	Thursday, February	<i>Time</i>	8 am
<i>Speed Limit</i>	60 km/hr	<i>Number of Pedestrians Involved</i>	1
<i>Travel Speed</i>	50 km/hr	<i>Travel Speed Source</i>	Driver
<i>Impact Speed</i>	48 km/hr	<i>Impact Speed Source</i>	Projection distance

Pedestrian Details

<i>Fatal</i>	Yes
<i>Age</i>	16
<i>Sex</i>	Male
<i>BAC Pedestrian</i>	0 %
<i>Action</i>	Running
<i>Movement</i>	Crossing the road
<i>Side Impacted</i>	Left side to vehicle

Driver Details

<i>Age</i>	22
<i>Sex</i>	Female
<i>BAC Driver</i>	0 %
<i>Driving Experience</i>	4 years
<i>Licence Type</i>	Full
<i>Driver Action</i>	Braked before impact

Impact Vehicle Details

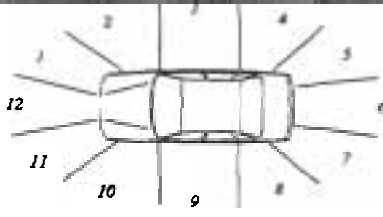
<i>Vehicle Model</i>	1972 Datsun 180B sedan	
<i>Type</i>	Car	
<i>Number Involved</i>	1	
<i>Modifications</i>	None	

Road Site Details

<i>Traffic Control</i>	None	<i>Road Type</i>	Arterial
<i>Traffic Conditions</i>	Moderate	<i>Road Alignment</i>	Curved
<i>Weather Conditions</i>	Fine, dry road	<i>Natural Lighting</i>	Day
<i>Number of Lanes</i>	3	<i>Street Lighting</i>	Not applicable
<i>Road Division</i>	Raised median strip		

	5 km/hr reduction	10 km/hr reduction	10% reduction	20% reduction
Travel Speed (km/hr)	45	40	45	40
Impact Speed (km/hr)	35	14	35	14

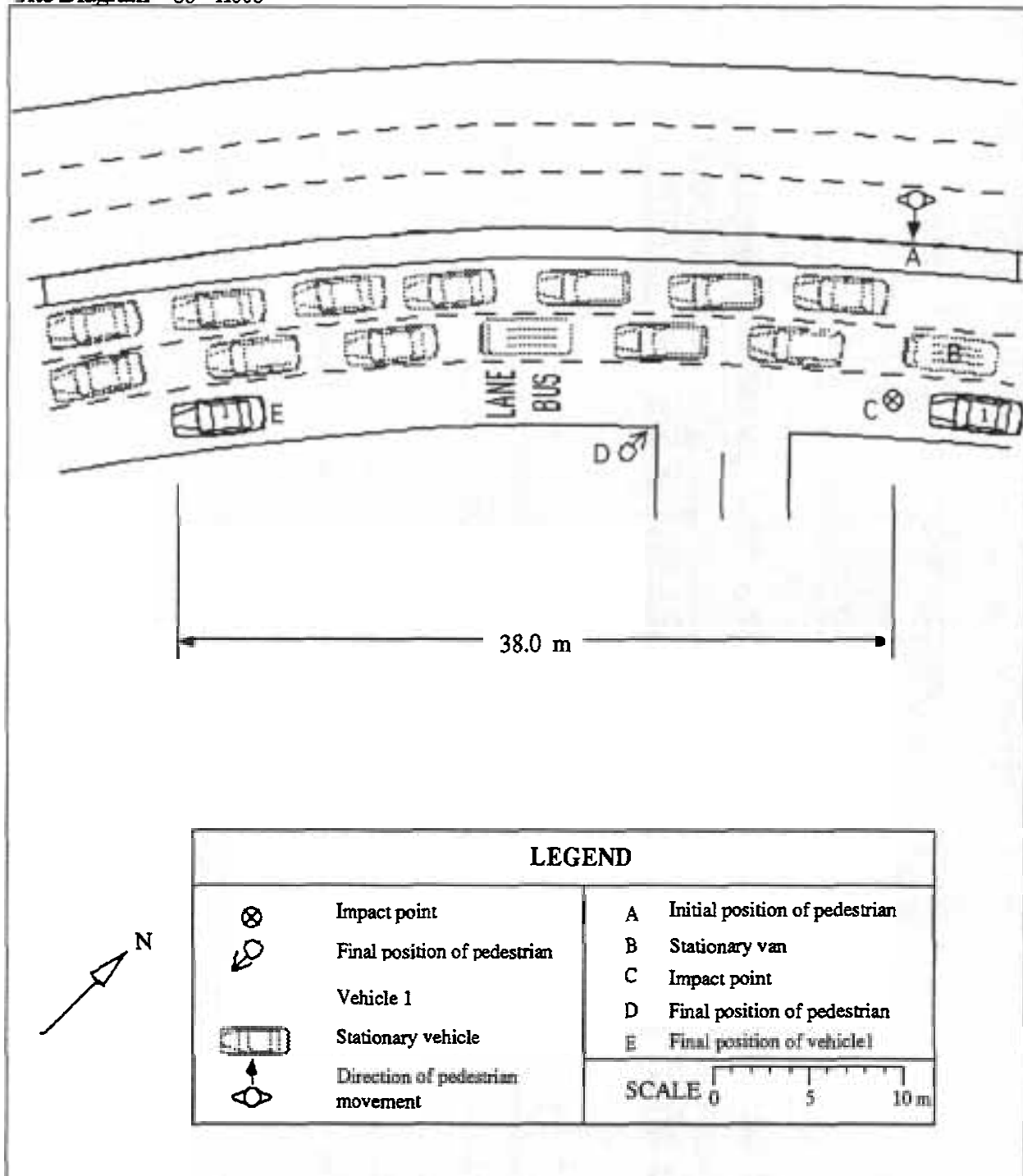

Accident Description

Vehicle 1 was travelling in a south westerly direction at 50 km/hr. Two pedestrians had crossed the northern carriageway and were stationary on the median strip (point A). Cars were stopped at the lights and the pedestrians moved between the stationary vehicles. When they approached the bus lane the lights were green. One pedestrian ran in front of vehicle 1 and the other hesitated then followed. The second pedestrian was hit. The driver estimated that she did not see the pedestrian until he was 1.5 metres in front of her because her view was obscured by a van in the second lane. As soon as the driver saw the pedestrian she braked, but collided with the pedestrian (point C). The pedestrian was hit on his left hand side by the middle of the front of the car. He rolled up and impacted his head on the windscreen and then went over the roof and off the left side of the car. His body came to rest at point D. The car stopped at point E.

Case Details

<i>Case Number</i>	88 - H007	<i>Calculation type</i>	2.2
<i>Date of Accident</i>	Saturday, March	<i>Time</i>	1 am
<i>Speed Limit</i>	60 km/hr	<i>Number of Pedestrians Involved</i>	1
<i>Travel Speed</i>	60 km/hr	<i>Travel Speed Source</i>	Driver
<i>Impact Speed</i>	46 km/hr	<i>Impact Speed Source</i>	Skid marks

Pedestrian Details

<i>Fatal</i>	Yes
<i>Age</i>	65
<i>Sex</i>	Male
<i>BAC Pedestrian</i>	0.163 %
<i>Action</i>	Walking
<i>Movement</i>	Crossing the road
<i>Side Impacted</i>	Left side to vehicle

Driver Details

<i>Age</i>	24
<i>Sex</i>	Male
<i>BAC Driver</i>	0.061 %
<i>Driving Experience</i>	7 years
<i>Licence Type</i>	Full
<i>Driver Action</i>	Braked before impact

Impact Vehicle Details

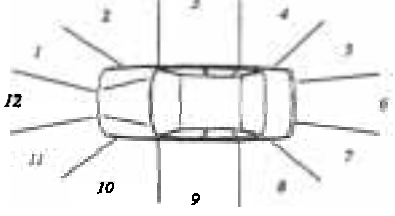
<i>Vehicle Model</i>	1970 Toyota Corolla sedan	<i>Impact Point</i>	1	
<i>Type</i>	Car			
<i>Number Involved</i>	1			
<i>Modifications</i>	None			

Road Site Details

<i>Traffic Control</i>	Traffic signal at intersection	<i>Road Type</i>	Arterial
<i>Traffic Conditions</i>	Light	<i>Road Alignment</i>	Straight
<i>Weather Conditions</i>	Fine, dry road	<i>Natural Lighting</i>	Night
<i>Number of Lanes</i>	5	<i>Street Lighting</i>	Street lights
<i>Road Division</i>	Raised median strip		

Reduced Travel Speed Analysis

	5 km/hr reduction	10 km/hr reduction	10% reduction	20% reduction
Travel Speed (km/hr)	55	50	54	48
Impact Speed (km/hr)	33	9	30	0

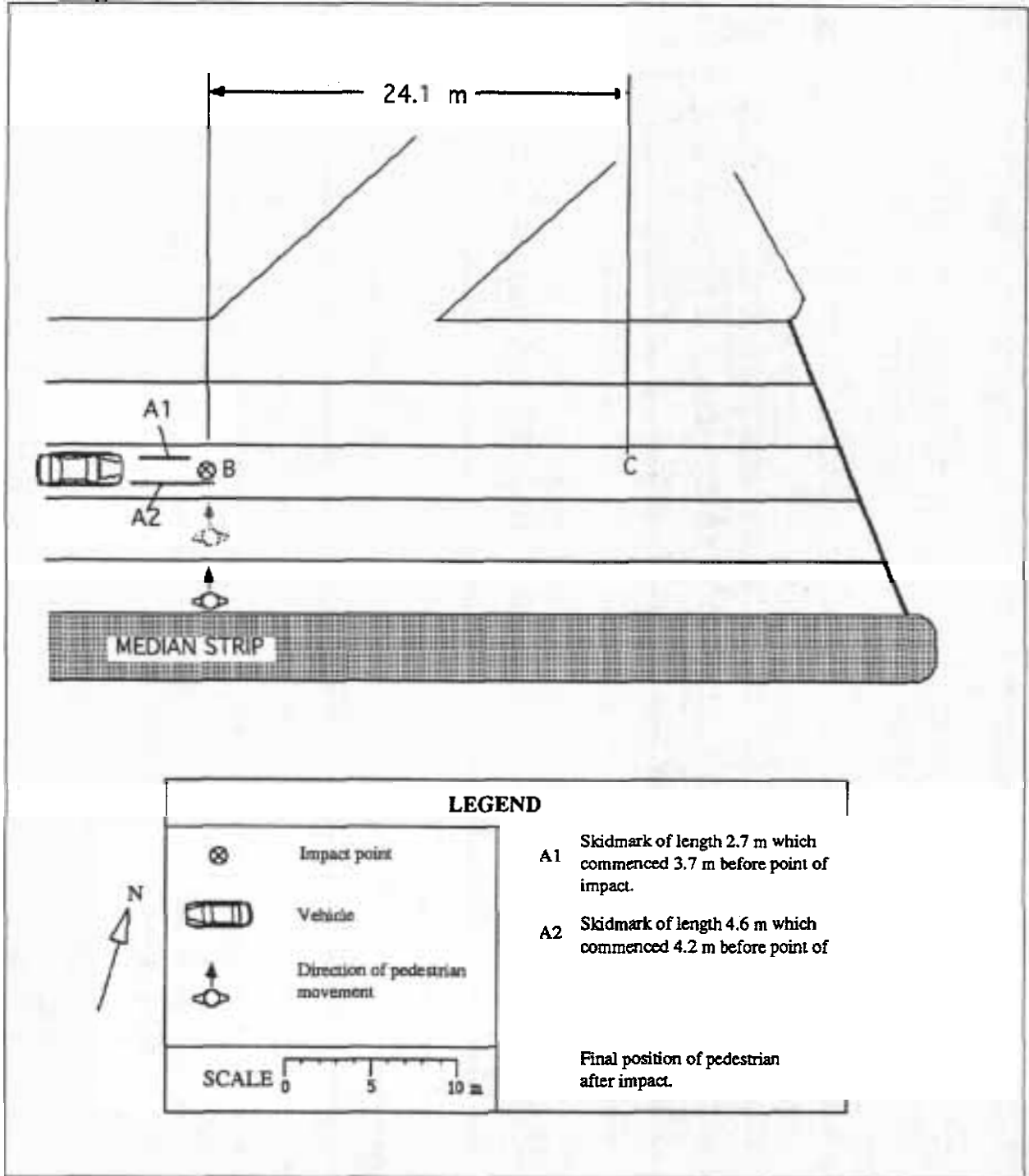

Accident Description

The car was travelling north east and collided with a pedestrian who was crossing the road in a north westerly direction. The driver stated that he was travelling at about 60 km/hr and estimated that he saw the pedestrian about two feet in front of him. The driver braked as soon as he saw the pedestrian, which was before impact as indicated by the impact point (point B) and skid marks (point A1 & A2). The driver then went through the intersection and stopped. The traffic lights at the intersection at the time were green for traffic heading north east . An independent witness supported the driver's estimated of travel speed.

Case Details

<i>Case Number</i>	88 - H010	<i>Calculation type</i>	2.3
<i>Date of Accident</i>	Thursday, March	<i>Time</i>	5 pm
<i>Speed Limit</i>	60 km/hr	<i>Number of Pedestrians Involved</i>	1
<i>Travel Speed</i>	62 km/hr	<i>Travel Speed Source</i>	Momentum Calculation
<i>Impact Speed</i>	62 km/hr	<i>Impact Speed Source</i>	Momentum calculation

Pedestrian Details

<i>Fatal</i>	Yes
<i>Age</i>	61
<i>Sex</i>	Male
<i>BAC Pedestrian</i>	0 %
<i>Action</i>	Walking
<i>Movement</i>	Crossing the road
<i>Side Impacted</i>	Right side to vehicle

Driver Details

<i>Age</i>	21
<i>Sex</i>	Male
<i>BAC Driver</i>	0 %
<i>Driving Experience</i>	Unknown
<i>Licence Type</i>	Probationary
<i>Driver Action</i>	Braked before impact

Impact Vehicle Details

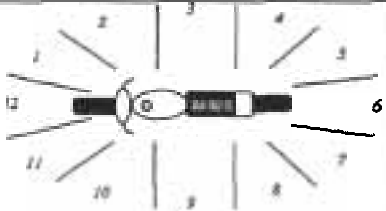
<i>Vehicle Model</i>	1979 Yamaha 250cc road bike	
<i>Type</i>	Motorcycle	
<i>Number Involved</i>	1	
<i>Modifications</i>	None	

Road Site Details

<i>Traffic Control</i>	None	<i>Road Type</i>	Arterial
<i>Traffic Conditions</i>	Heavy	<i>Road Alignment</i>	Straight
<i>Weather Conditions</i>	Fine, dry road	<i>Natural Lighting</i>	Day
<i>Number of Lanes</i>	2	<i>Street Lighting</i>	Not applicable
<i>Road Division</i>	Centre line		

Reduced Travel Speed Analysis

	5 km/hr reduction	10 km/hr reduction	10% reduction	20% reduction
Travel Speed (km/hr)	57	52	55	49
Impact Speed (km/hr)	53	44	51	39

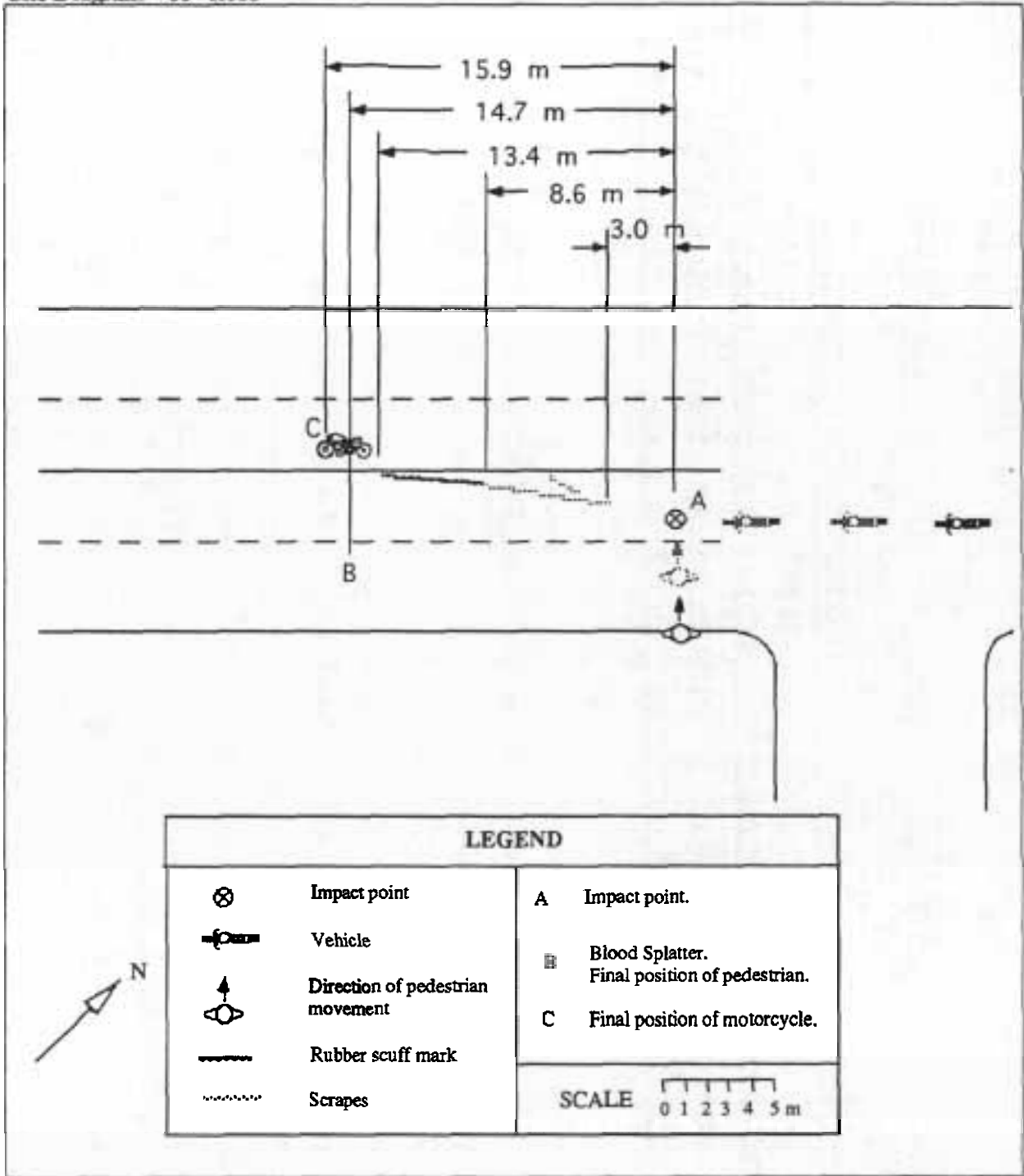

Accident Description

A motorcycle travelling in a south westerly direction collided with a pedestrian who was crossing the road in a north westerly direction. The rider stated that he was travelling at about 62 km/hr in the lane closest to the centre of the road. The rider also stated that he was looking at his rear vision mirror just prior to the impact and when he looked up the pedestrian was in front of him. The rider braked before impact and said that the vehicle slowed down a bit but not much. There was no other witnesses.

Case Details

<i>Case Number</i>	88 - H012	<i>Calculation type</i>	4.1
<i>Date of Accident</i>	Friday, April	<i>Time</i>	3 am
<i>Speed Limit</i>	80 km/hr	<i>Number of Pedestrians Involved</i>	1
<i>Travel Speed</i>	80 km/hr	<i>Travel Speed Source</i>	Driver
<i>Impact Speed</i>	80 km/hr	<i>Impact Speed Source</i>	Projection distance

Pedestrian Details

<i>Fatal</i>	Yes
<i>Age</i>	23
<i>Sex</i>	Male
<i>BAC Pedestrian</i>	0.253 %
<i>Action</i>	Lying on road
<i>Movement</i>	See above
<i>Side Impacted</i>	Left side to vehicle

Driver Details

<i>Age</i>	34
<i>Sex</i>	Male
<i>BAC Driver</i>	0 %
<i>Driving Experience</i>	12 years
<i>Licence Type</i>	Full
<i>Driver Action</i>	Braked after impact

Impact Vehicle Details

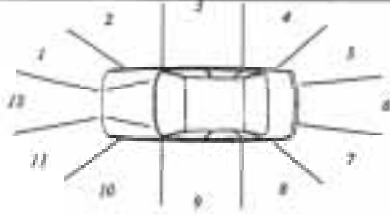
<i>Vehicle Model</i>	1974 Ford Fairlane	
<i>Type</i>	Car	
<i>Impact Point</i>	11	
<i>Number Involved</i>	1	
<i>Modifications</i>	None	

Road Site Details

<i>Traffic Control</i>	Traffic signal at intersection	<i>Road Type</i>	Arterial
<i>Traffic Conditions</i>	Light	<i>Road Alignment</i>	Not applicable
<i>Weather Conditions</i>	Fine, dry road	<i>Natural Lighting</i>	Night
<i>Number of Lanes</i>	4	<i>Street Lighting</i>	Street lights
<i>Road Division</i>	Raised median strip		

Reduced Travel Speed Analysis

	5 km/hr reduction	10 km/hr reduction	10% reduction	20% reduction
Travel Speed (km/hr)	75	70	72	64
Impact Speed (km/hr)	71	61	65	47

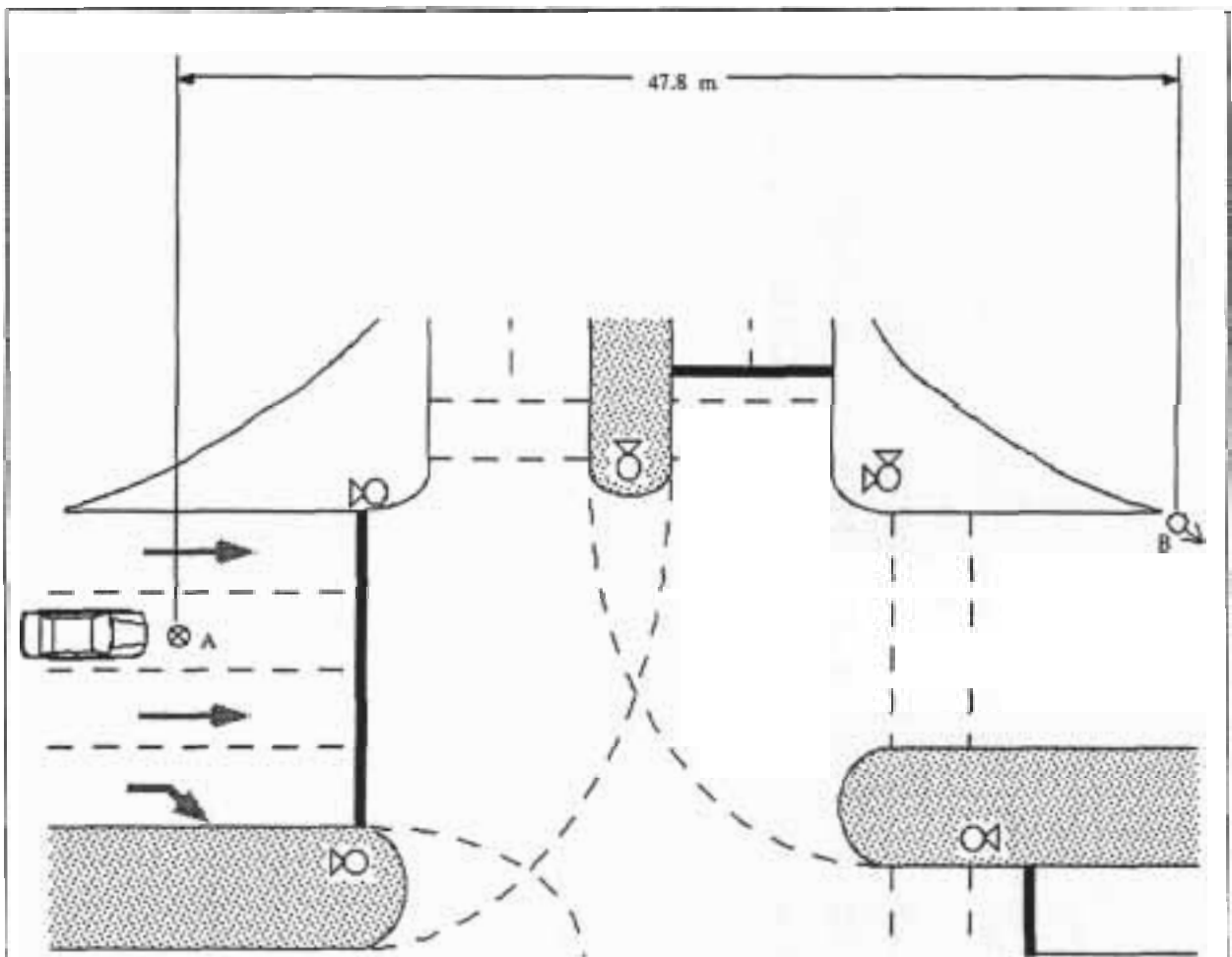

	Impact point	A	Impact point
	Final position of pedestrian	B	Final position of pedestrian
	Vehicle		
SCALE		N	

Case Details

<i>Case Number</i>	88 - H015	<i>Calculation type</i>	1
<i>Date of Accident</i>	Tuesday, May	<i>Time</i>	3 pm
<i>Speed Limit</i>	60 km/hr	<i>Number of Pedestrians Involved</i>	1
<i>Travel Speed</i>	92 km/hr	<i>Travel Speed Source</i>	Projection distance
<i>Impact Speed</i>	92 km/hr	<i>Impact Speed Source</i>	Projection distance

Pedestrian Details

<i>Fatal</i>	Yes
<i>Age</i>	12
<i>Sex</i>	Male
<i>BAC Pedestrian</i>	0 %
<i>Action</i>	Running
<i>Movement</i>	Crossing the road
<i>Side Impacted</i>	Right side to vehicle

Driver Details

<i>Age</i>	26
<i>Sex</i>	Male
<i>BAC Driver</i>	0 %
<i>Driving Experience</i>	10 years
<i>Licence Type</i>	Unknown
<i>Driver Action</i>	No evasive action

Impact Vehicle Details

<i>Vehicle Model</i>	1985 Toyota Land Cruiser	<i>Impact Point</i>	11
<i>Type</i>	Multi purpose vehicle		
<i>Number Involved</i>	1		
<i>Modifications</i>	None		

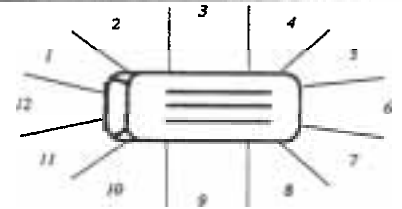

Road Site Details

<i>Traffic Control</i>	None	<i>Road Type</i>	Other main traffic route
<i>Traffic Conditions</i>	Moderate		
<i>Weather Conditions</i>	Fine, dry road	<i>Road Alignment</i>	Straight
<i>Number of Lanes</i>	1	<i>Natural Lighting</i>	Day
<i>Road Division</i>	Centre line	<i>Street Lighting</i>	None

Reduced Travel Speed Analysis

	5 km/hr reduction	10 km/hr reduction	10% reduction	20% reduction
Travel Speed (km/hr)	87	82	83	74
Impact Speed (km/hr)	87	82	83	74

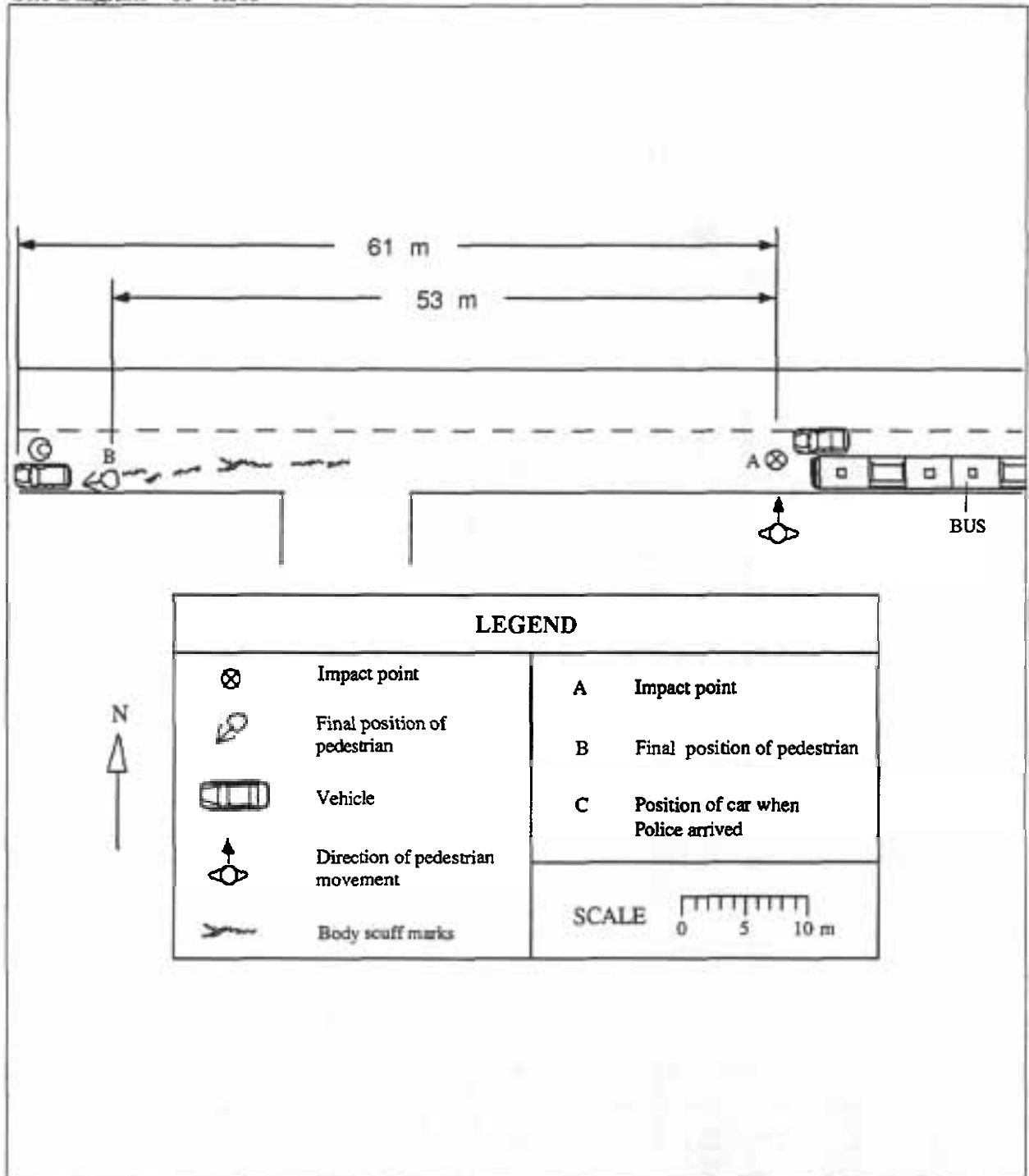

Accident Description

Vehicle 1 was travelling in a westerly direction at about 92 km/hr. The pedestrian had alighted from a bus stopped at the southern kerb, ran in front of it in a northerly direction across the road and was struck by the front corner of vehicle 1 (at point A). The driver had no time for any evasive action before the collision, but he did swerve after the impact. The pedestrian was hit on his right hand side by the front left corner of the vehicle and then struck his head midway up the bonnet. He fell off to the left side of the car and was projected along the road to point B. The driver of the car stopped near the kerb and reversed back to where the pedestrian was lying.

Case Details

<i>Case Number</i>	88 - H016	<i>Calculation type</i>	1
<i>Date of Accident</i>	Tuesday, May	<i>Time</i>	2 pm
<i>Speed Limit</i>	60 km/hr	<i>Number of Pedestrians Involved</i>	1
<i>Travel Speed</i>	60 km/hr	<i>Travel Speed Source</i>	Driver
<i>Impact Speed</i>	60 km/hr	<i>Impact Speed Source</i>	Driver

Pedestrian Details

<i>Fatal</i>	Yes
<i>Age</i>	64
<i>Sex</i>	Female
<i>BAC Pedestrian</i>	0 %
<i>Action</i>	Walking
<i>Movement</i>	Crossing the road
<i>Side Impacted</i>	Right side to vehicle

Driver Details

<i>Age</i>	23
<i>Sex</i>	Male
<i>BAC Driver</i>	0 %
<i>Driving Experience</i>	5 years
<i>Licence Type</i>	Full
<i>Driver Action</i>	No evasive action

Impact Vehicle Details

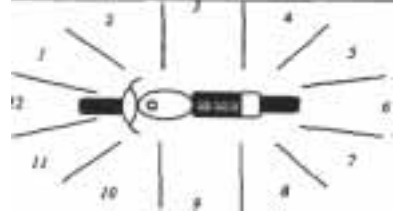
<i>Vehicle Model</i>	1985 Kawasaki GPZ 900R Solo road bike	
<i>Type</i>	Motorcycle	
<i>Impact Point</i>	11	
<i>Number Involved</i>	1	
<i>Modifications</i>	None	

Road Site Details

<i>Traffic Control</i>	None	<i>Road Type</i>	Arterial
<i>Traffic Conditions</i>	Light	<i>Road Alignment</i>	Straight
<i>Weather Conditions</i>	Fine, dry road	<i>Natural Lighting</i>	Day
<i>Number of Lanes</i>	2	<i>Street Lighting</i>	Not applicable
<i>Road Division</i>	Raised median strip		

	5 km/hr reduction	10 km/hr reduction	10% reduction	20% reduction
Travel Speed (km/hr)	55	50	54	48
Impact Speed (km/hr)	55	50	54	48

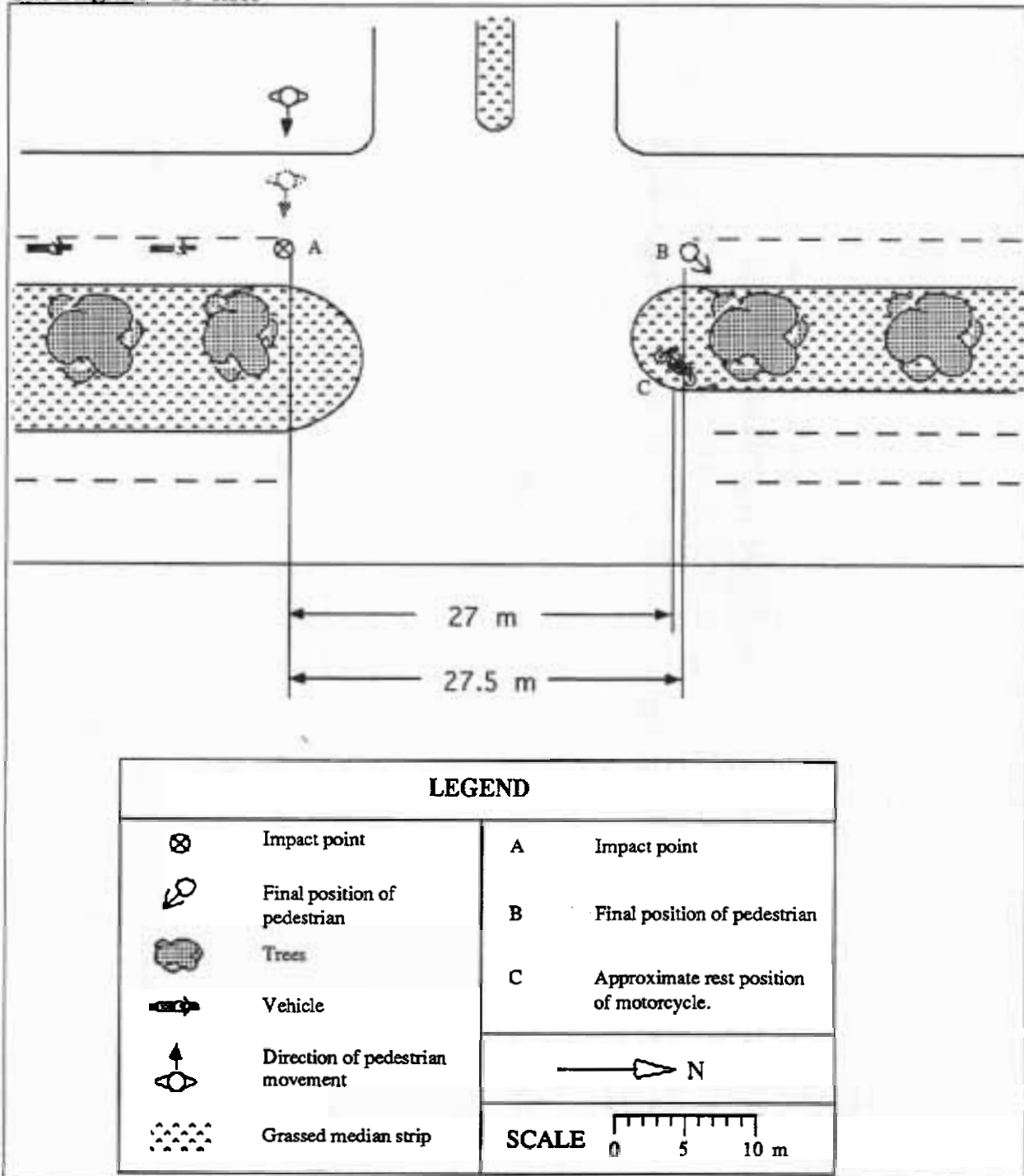

Accident Description

The motorcycle was travelling north in the lane closest to the median strip when it collided with a pedestrian crossing the road from west to east. The rider stated that he was travelling at about 60 km/hr and first saw the pedestrian about 14 metres away near the centre line dividing the two lanes. The rider did not brake or swerve before the impact. An independent witness to the accident estimated the speed of the motorcycle to be 70 to 80 km/hr. The witness was travelling south at that time and was level with the junction of the roads. Another witness, who had been overtaken by the motorcycle, estimated that the vehicle was travelling at 110 to 120 km/hr approximately 370 metres south of the point of impact. After impact, the rider was knocked out of his seat but manage to ride the motorcycle over the median strip and over the kerb, where it was involved with a minor collision with a tree.

Case Details

<i>Case Number</i>	88 - H020	<i>Calculation type</i>	2.1
<i>Date of Accident</i>	Friday, June	<i>Time</i>	8 am
<i>Speed Limit</i>	60 km/hr	<i>Number of Pedestrians Involved</i>	1
<i>Travel Speed</i>	93 km/hr	<i>Travel Speed Source</i>	Skid marks
<i>Impact Speed</i>	83 km/hr	<i>Impact Speed Source</i>	Skid marks

Pedestrian Details

<i>Fatal</i>	Yes
<i>Age</i>	75
<i>Sex</i>	Female
<i>BAC Pedestrian</i>	0 %
<i>Action</i>	Walking
<i>Movement</i>	Crossing the road
<i>Side Impacted</i>	Left side to vehicle

Driver Details

<i>Age</i>	17
<i>Sex</i>	Male
<i>BAC Driver</i>	0 %
<i>Driving Experience</i>	1 years
<i>Licence Type</i>	Full
<i>Driver Action</i>	Braked before impact

Impact Vehicle Details

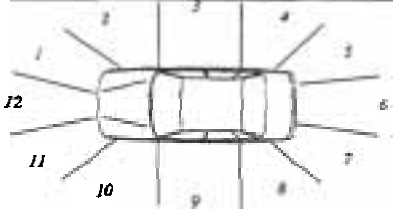
<i>Vehicle Model</i>	1972 Holden Statesman sedan	
<i>Type</i>	Car	
<i>Number Involved</i>	1	<i>Impact Point</i> 1
<i>Modifications</i>	None	

Road Site Details

<i>Traffic Control</i>	None	<i>Road Type</i>	Arterial
<i>Traffic Conditions</i>	Moderate	<i>Road Alignment</i>	Straight
<i>Weather Conditions</i>	Fine, dry road	<i>Natural Lighting</i>	Day
<i>Number of Lanes</i>	2	<i>Street Lighting</i>	Not applicable
<i>Road Division</i>	Painted median strip		

Reduced Travel Speed Analysis

	5 km/hr reduction	10 km/hr reduction	10% reduction	20% reduction
Travel Speed (km/hr)	88	83	83	74
Impact Speed (km/hr)	75	67	68	50

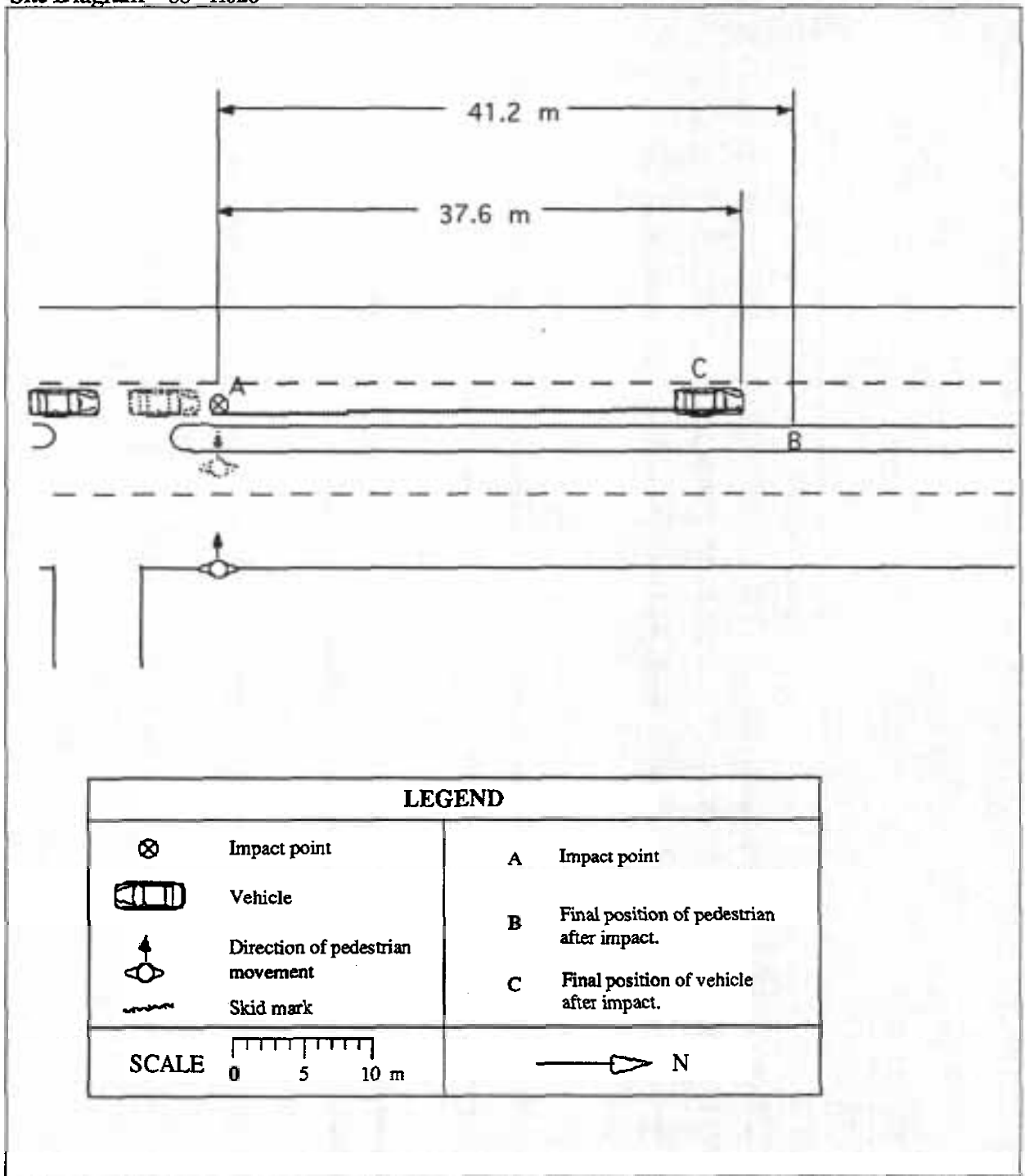

Accident Description

Vehicle 1 travelling north in the lane closest to the median strip at 93 km/hr, collided with the pedestrian (at point A) who was crossing the road from east to west. The driver stated that he thought the pedestrian saw him but the pedestrian continued to run across in front of him. The pedestrian was hit on the lateral side of her right leg and came to rest at point B after the collision. The driver was found to be responsible for the pedestrian's death due to excessive speed, inexperience in driving a powerful car and driving not in accordance with traffic conditions.

Case Details

<i>Case Number</i>	88 - H023	<i>Calculation type</i>	1
<i>Date of Accident</i>	Monday, June	<i>Time</i>	11 am
<i>Speed Limit</i>	60 km/hr	<i>Number of Pedestrians Involved</i>	1
<i>Travel Speed</i>	60 km/hr	<i>Travel Speed Source</i>	Driver
<i>Impact Speed</i>	60 km/hr	<i>Impact Speed Source</i>	Driver

Pedestrian Details

<i>Fatal</i>	Yes
<i>Age</i>	73
<i>Sex</i>	Female
<i>BAC Pedestrian</i>	0 %
<i>Action</i>	Running
<i>Movement</i>	Crossing the road
<i>Side Impacted</i>	Facing vehicle

Driver Details

<i>Age</i>	59
<i>Sex</i>	Female
<i>BAC Driver</i>	0 %
<i>Driving Experience</i>	35 years
<i>Licence Type</i>	Full
<i>Driver Action</i>	Braked after impact

Impact Vehicle Details

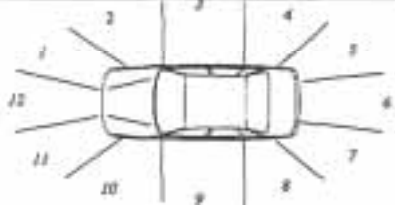
<i>Vehicle Model</i>	1978 Volkswagen Golf hatch back		
<i>Type</i>	Car		<i>Impact Point</i> 11
<i>Number Involved</i>	1		
<i>Modifications</i>	None		

Road Site Details

<i>Traffic Control</i>	None	<i>Road Type</i>	Arterial
<i>Traffic Conditions</i>	Moderate	<i>Road Alignment</i>	Straight
<i>Weather Conditions</i>	Fine, dry road	<i>Natural Lighting</i>	Day
<i>Number of Lanes</i>	2	<i>Street Lighting</i>	Not applicable
<i>Road Division</i>	Raised median strip		

Reduced Travel Speed Analysis

	5 km/hr reduction	10 km/hr reduction	10% reduction	20% reduction
Travel Speed (km/hr)	55	50	54	48
Impact Speed (km/hr)	55	50	54	48

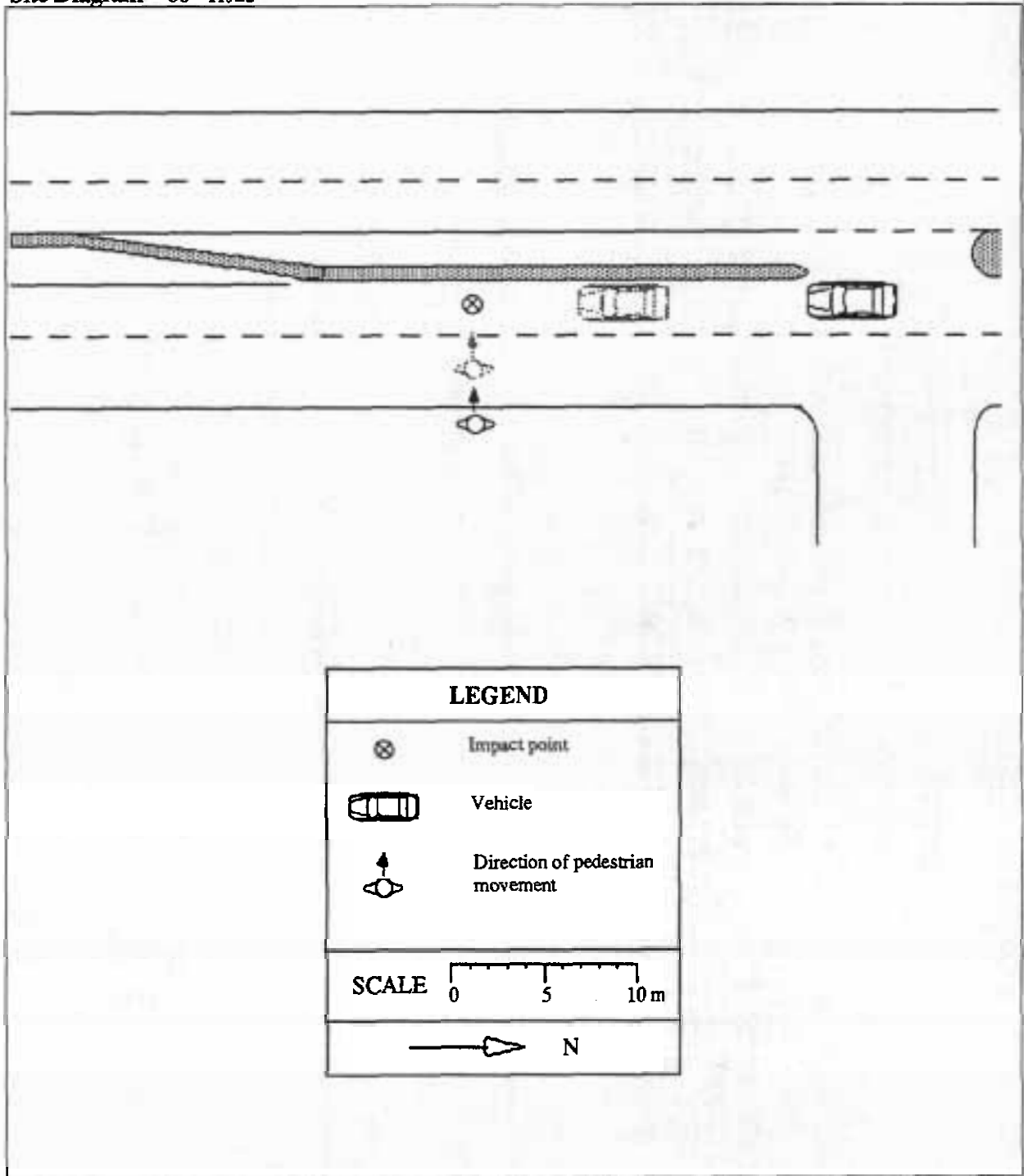

Accident Description

The car was travelling in a southerly direction at about 60 km/hr. The pedestrian was running across the road from east to west. The driver stated that she first saw the pedestrian in the left lane. The driver did not take any evasive action as she assumed that the pedestrian would stop at the lane marking, but the pedestrian continued and ran into the front left corner of the vehicle. The final positions of the vehicle and the pedestrian are unknown.

Case Details

<i>Case Number</i>	88 - H025	<i>Calculation type</i>	1
<i>Date of Accident</i>	Sunday, July	<i>Time</i>	2 am
<i>Speed Limit</i>	60 km/hr	<i>Number of Pedestrians Involved</i>	1
<i>Travel Speed</i>	60 km/hr	<i>Travel Speed Source</i>	Driver
<i>Impact Speed</i>	60 km/hr	<i>Impact Speed Source</i>	Driver

Pedestrian Details

<i>Fatal</i>	Yes
<i>Age</i>	15
<i>Sex</i>	Female
<i>BAC Pedestrian</i>	0.042 %
<i>Action</i>	Walking
<i>Movement</i>	Along the road
<i>Side Impacted</i>	Facing vehicle

Driver Details

<i>Age</i>	32
<i>Sex</i>	Male
<i>BAC Driver</i>	0.13 %
<i>Driving Experience</i>	16 years
<i>Licence Type</i>	Full
<i>Driver Action</i>	Braked after impact

Impact Vehicle Details

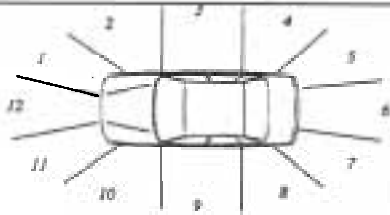
<i>Vehicle Model</i>	1975 Triumph 2500 sedan		
<i>Type</i>	Car		
<i>Number Involved</i>	1		
<i>Modifications</i>	None		
		<i>Impact Point</i>	11

Road Site Details

<i>Traffic Control</i>	None	<i>Road Type</i>	Arterial
<i>Traffic Conditions</i>	Light	<i>Road Alignment</i>	Straight
<i>Weather Conditions</i>	Raining	<i>Natural Lighting</i>	Night
<i>Number of Lanes</i>	1	<i>Street Lighting</i>	None
<i>Road Division</i>	Centre line		

Reduced Travel Speed Analysis

	5 km/hr reduction	10 km/hr reduction	10% reduction	20% reduction
Travel Speed (km/hr)	55	50	54	48
Impact Speed (km/hr)	55	50	54	48

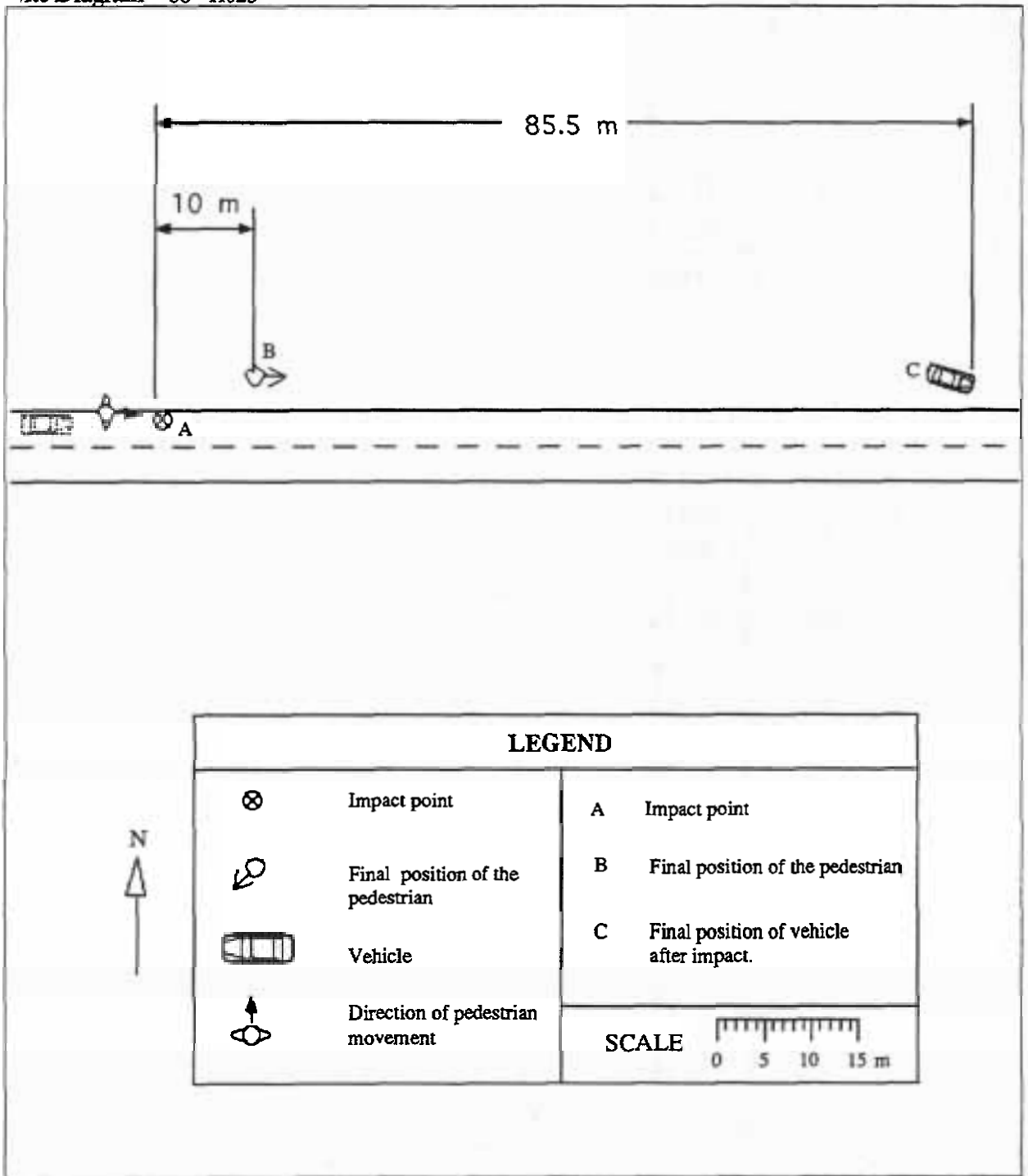

Accident Description

The car was travelling east at about 60 km/hr when it struck a pedestrian walking on the roadway in the same direction. The driver stated that he did not see the pedestrian prior to the collision and no evasive action was taken. The pedestrian was struck from behind by the front left side of the vehicle.

Note: The pedestrian was arrested before the accident for walking on roadway and other offences, in the vicinity of the accident scene.

Case Details

<i>Case Number</i>	88 - H035	<i>Calculation type</i>	1
<i>Date of Accident</i>	Wednesday, September	<i>Time</i>	7 pm
<i>Speed Limit</i>	80 km/hr	<i>Number of Pedestrians Involved</i>	1
<i>Travel Speed</i>	100 km/hr	<i>Travel Speed Source</i>	Witness
<i>Impact Speed</i>	100 km/hr	<i>Impact Speed Source</i>	Witness

Pedestrian Details

<i>Fatal</i>	Yes
<i>Age</i>	17
<i>Sex</i>	Female
<i>BAC Pedestrian</i>	0 %
<i>Action</i>	Walking
<i>Movement</i>	Crossing the road
<i>Side Impacted</i>	Left side to vehicle

Driver Details

<i>Age</i>	15
<i>Sex</i>	Male
<i>BAC Driver</i>	Unknown
<i>Driving Experience</i>	5 days
<i>Licence Type</i>	None
<i>Driver Action</i>	No evasive action

Impact Vehicle Details

<i>Vehicle Model</i>	1984 Nissan Skyline sedan	<i>Impact Point</i>	1
<i>Type</i>	Car		
<i>Number Involved</i>	2		
<i>Modifications</i>	None		

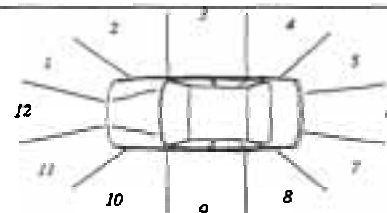

Road Site Details

<i>Traffic Control</i>	None	<i>Road Type</i>	Arterial
<i>Traffic Conditions</i>	Light	<i>Road Alignment</i>	Straight
<i>Weather Conditions</i>	Fine, dry road	<i>Natural Lighting</i>	Night
<i>Number of Lanes</i>	1	<i>Street Lighting</i>	Street lights
<i>Road Division</i>	Centre line		

Reduced Travel Speed Analysis

	5 km/hr reduction	10 km/hr reduction	10% reduction	20% reduction
Travel Speed (km/hr)	95	90	90	80
Impact Speed (km/hr)	95	90	90	80

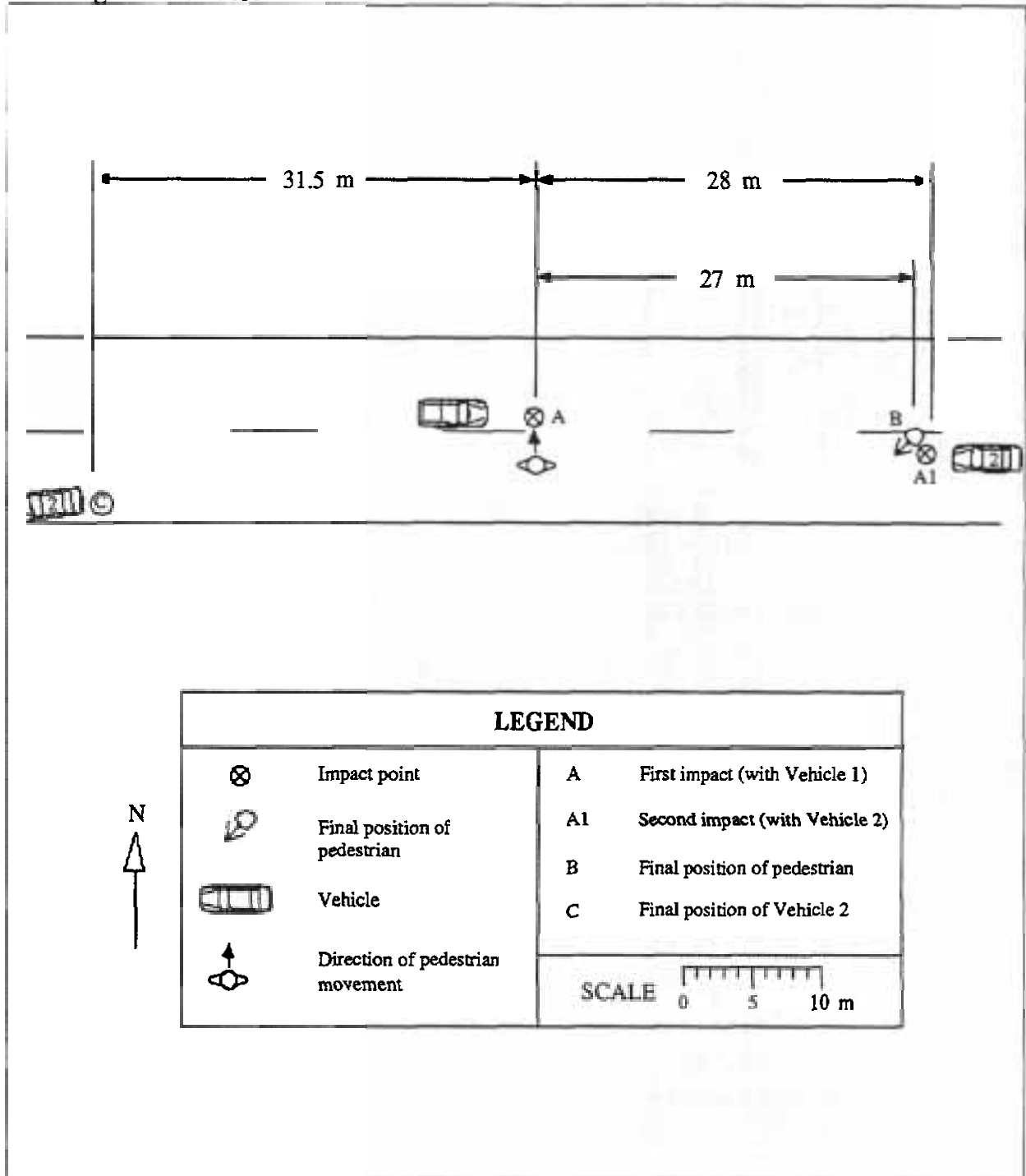

Accident Description

Vehicle 1 was travelling in an easterly direction at 100 km/hr. The pedestrian was walking in a southerly direction and when she got to the centre of the road her friend called out. She then turned round and took one step north and was hit on her left hand side by the front right corner of Vehicle 1. She was thrown about 30 metres east and came to rest at point A1. Vehicle 1 did not brake or stop at the accident scene. Two vehicles were travelling west, and the first swerved left and was able to avoid hitting the pedestrian, but the second did not see her and ran over her, rolling her along the road to point B. Vehicle 2, a 1970 HT Holden Sedan stopped at point C.

Case Details

<i>Case Number</i>	88 - H038	<i>Calculation type</i>	3.1
<i>Date of Accident</i>	Saturday, October	<i>Time</i>	4 pm
<i>Speed Limit</i>	60 km/hr	<i>Number of Pedestrians Involved</i>	1
<i>Travel Speed</i>	50 km/hr	<i>Travel Speed Source</i>	Driver
<i>Impact Speed</i>	23 km/hr	<i>Impact Speed Source</i>	Projection distance

Pedestrian Details

<i>Fatal</i>	Yes
<i>Age</i>	72
<i>Sex</i>	Male
<i>BAC Pedestrian</i>	0 %
<i>Action</i>	Walking
<i>Movement</i>	Crossing the road
<i>Side Impacted</i>	Left side to vehicle

Driver Details

<i>Age</i>	30
<i>Sex</i>	Male
<i>BAC Driver</i>	0 %
<i>Driving Experience</i>	12 years
<i>Licence Type</i>	Full
<i>Driver Action</i>	Braked before impact

Impact Vehicle Details

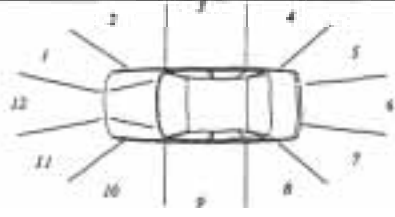
<i>Vehicle Model</i>	1976 Datsun 120Y sedan	
<i>Type</i>	Car	
<i>Number Involved</i>	1	
<i>Modifications</i>	None	

Road Site Details

<i>Traffic Control</i>	None	<i>Road Type</i>	Arterial
<i>Traffic Conditions</i>	Moderate	<i>Road Alignment</i>	Straight
<i>Weather Conditions</i>	Fine, dry road	<i>Natural Lighting</i>	Day
<i>Number of Lanes</i>	2	<i>Street Lighting</i>	Not applicable
<i>Road Division</i>	Centre line		

	5 km/hr reduction	10 km/hr reduction	10% reduction	20% reduction
Travel Speed (km/hr)	45	40	45	40
Impact Speed (km/hr)	0	0	0	0

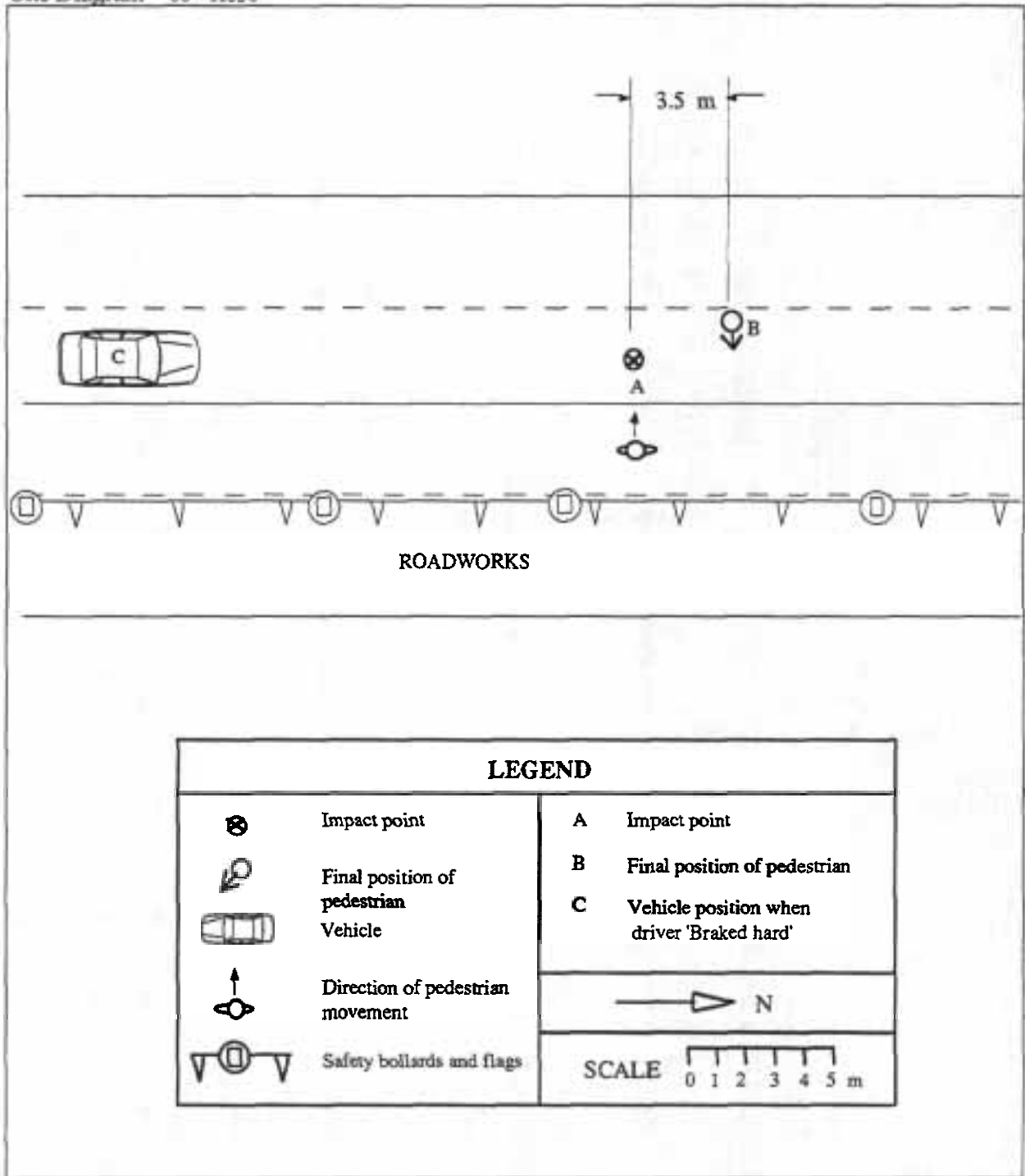

Accident Description

The car was travelling in a northerly direction in the right hand lane. The pedestrian was crossing the road in a westerly direction. The driver saw the pedestrian when he was 30 metres away and slowed to about 50 km/hr, he then saw the pedestrian stop on the lane marking so he continued on but did not accelerate. When the vehicle was 3 car lengths away (at point C), the pedestrian stepped in front of the vehicle, and the driver braked hard. The pedestrian was hit (at point A) on his left hand side by the centre of the car and he then rolled onto the bonnet impacting with the windscreen before rolling forward off the front of the car coming to rest at point B.

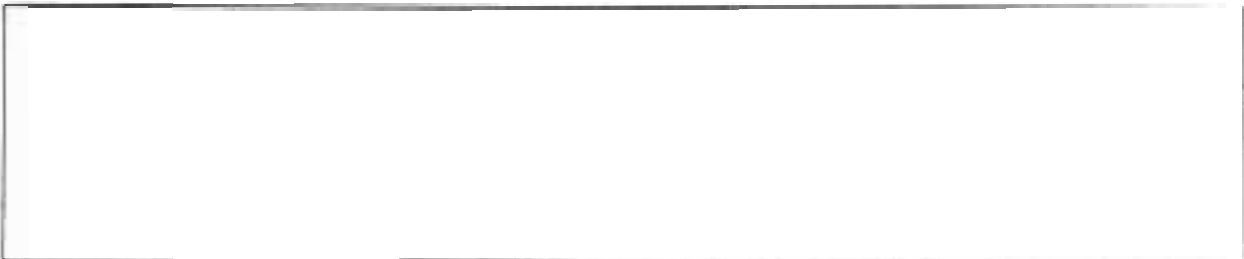

<i>Fatal</i>	Yes
<i>Age</i>	53
<i>Sex</i>	Male
<i>BAC Pedestrian</i>	0.295 %
<i>Action</i>	Walking
<i>Movement</i>	Crossing the road
<i>Side Impacted</i>	Left side to vehicle

<i>Age</i>	26
<i>Sex</i>	Male
<i>BAC Driver</i>	0 %
<i>Driving Experience</i>	Unknown years
<i>Licence Type</i>	Full
<i>Driver Action</i>	Braked after impact

1



Road Site Details

<i>Traffic Control</i>	None	<i>Road Type</i>	Arterial
<i>Traffic Conditions</i>	Light	<i>Road Alignment</i>	Straight
<i>Weather Conditions</i>	Fine, dry road	<i>Natural Lighting</i>	Night
<i>Number of Lanes</i>	2	<i>Street Lighting</i>	None
<i>Road Division</i>	Raised median strip		

Reduced Travel Speed Analysis

	5 km/hr	10 km/hr	10%	20%
Travel Speed (km/hr)	75	70	72	64
Impact Speed (km/hr)	75	70	72	64

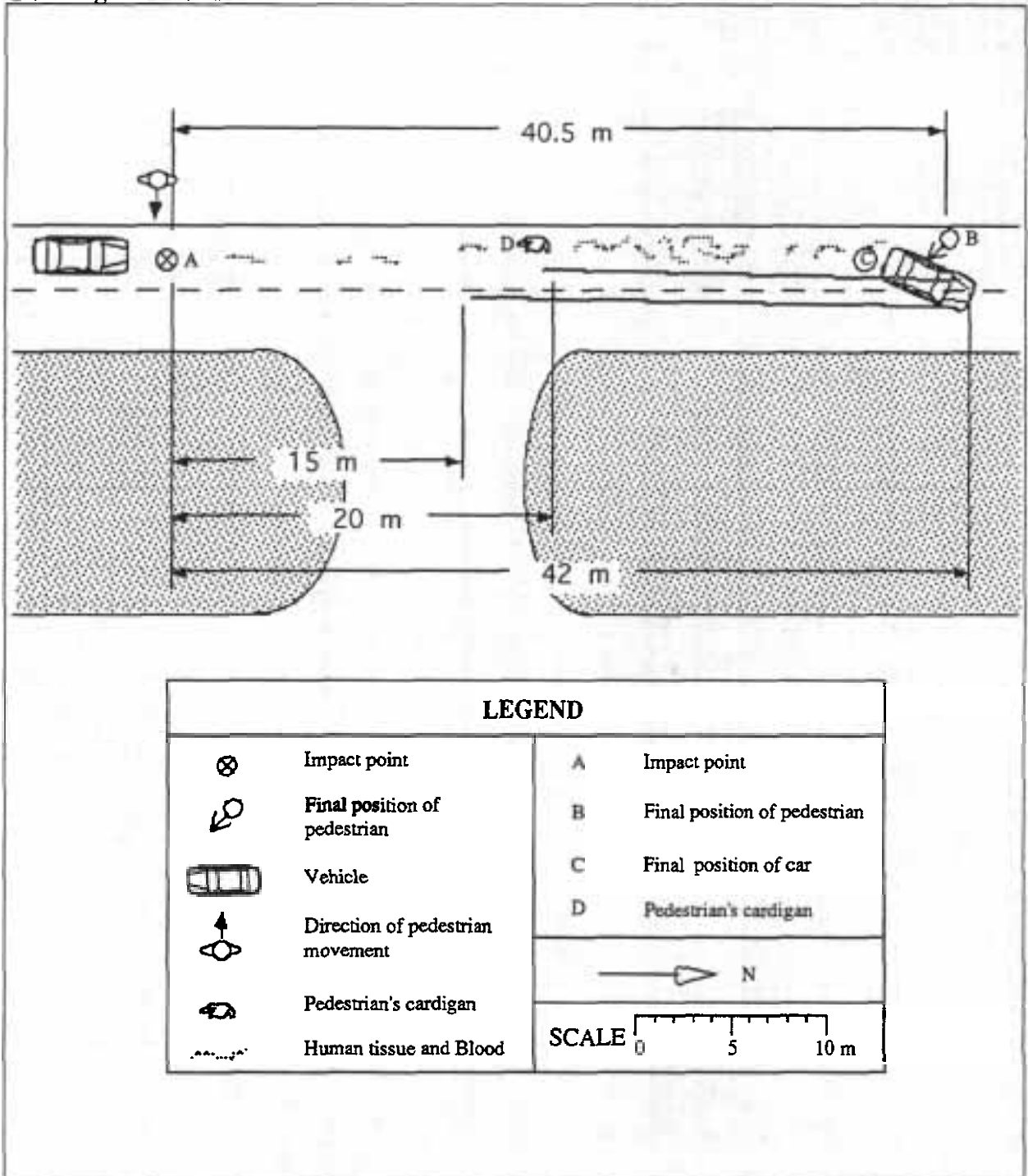

Accident Description

The car was travelling in a northerly direction at about 80 km/hr. The pedestrian was crossing the road in a westerly direction and was struck at point A on his left hand side. The pedestrian came to rest at point B and the car stopped at point C. The pedestrian's cardigan was found at point D. A large amount of brain matter was scattered along the road between points A & C.

Case Details

<i>Case Number</i>	88 - H048	<i>Calculation type</i>	1
<i>Date of Accident</i>	Saturday, December	<i>Time</i>	5 am
<i>Speed Limit</i>	80 km/hr	<i>Number of Pedestrians Involved</i>	1
<i>Travel Speed</i>	65 km/hr	<i>Travel Speed Source</i>	Driver
<i>Impact Speed</i>	65 km/hr	<i>Impact Speed Source</i>	Driver

Pedestrian Details

<i>Fatal</i>	Yes
<i>Age</i>	17
<i>Sex</i>	Male
<i>BAC Pedestrian</i>	0.218 %
<i>Action</i>	Walking
<i>Movement</i>	Crossing the road
<i>Side Impacted</i>	Right side to vehicle

Driver Details

<i>Age</i>	33
<i>Sex</i>	Male
<i>BAC Driver</i>	0 %
<i>Driving Experience</i>	17 years
<i>Licence Type</i>	Full
<i>Driver Action</i>	Other avoiding action taken

Impact Vehicle Details

<i>Vehicle Model</i>	1976 Toyota Hiace van	<i>Impact Point</i>	11
<i>Type</i>	Van		
<i>Number Involved</i>	1		
<i>Modifications</i>	None		

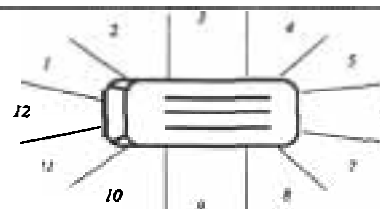

Road Site Details

<i>Traffic Control</i>	None	<i>Road Type</i>	Arterial
<i>Traffic Conditions</i>	Light	<i>Road Alignment</i>	Straight
<i>Weather Conditions</i>	Fine, dry road	<i>Natural Lighting</i>	Dawn
<i>Number of Lanes</i>	1	<i>Street Lighting</i>	None
<i>Road Division</i>	Centre line		

	5 km/hr reduction	10 km/hr reduction	10% reduction	20% reduction
Travel Speed (km/hr)	60	55	59	52
Impact Speed (km/hr)	60	55	59	52

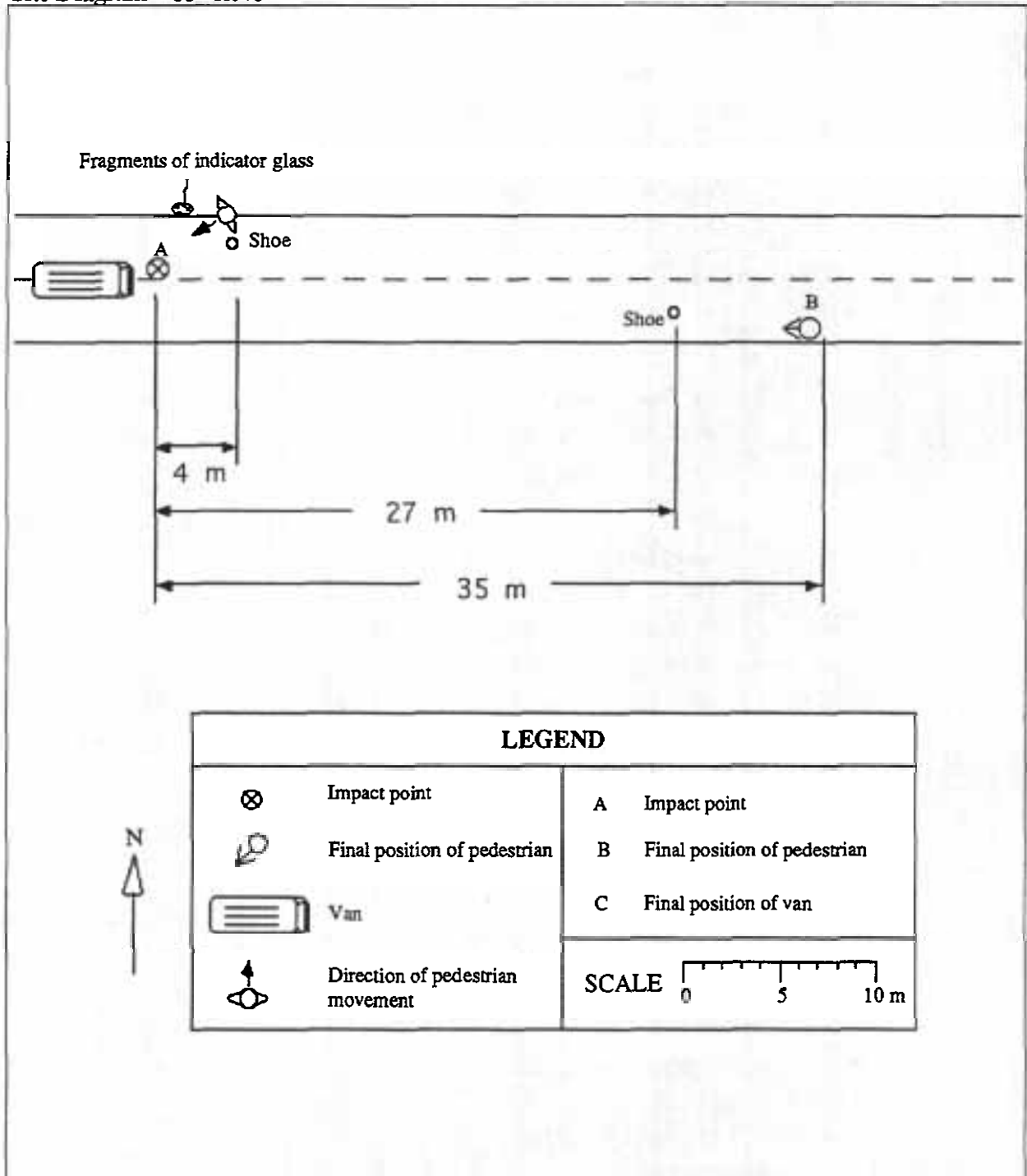

Accident Description

The van was travelling in an easterly direction at 65 km/hr. The driver states that he saw the pedestrian jogging on the northern gravel shoulder of the road. He moved his van to the right and slowed down to give more of a 'buffer' to the pedestrian. He further states that the further out he moved, the further out the pedestrian moved into his path. A collision occurred when the left side of the van was positioned over the white centre line at point A. The pedestrian was hit on his right side by the left front corner of the van and his head impacted the windscreen. He was then thrown forward and came to rest at point B. The driver of the van drove from the scene to get help and returned later on.

Case Details

<i>Case Number</i>	89 - H001	<i>Calculation type</i>	3.1
<i>Date of Accident</i>	Thursday, January	<i>Time</i>	1 pm
<i>Speed Limit</i>	60 km/hr	<i>Number of Pedestrians Involved</i>	1
<i>Travel Speed</i>	50 km/hr	<i>Travel Speed Source</i>	Driver
<i>Impact Speed</i>	43 km/hr	<i>Impact Speed Source</i>	Projection distance

Pedestrian Details

<i>Fatal</i>	Yes
<i>Age</i>	77
<i>Sex</i>	Male
<i>BAC Pedestrian</i>	0 %
<i>Action</i>	Walking
<i>Movement</i>	Crossing the road
<i>Side Impacted</i>	Left side to vehicle

Driver Details

<i>Age</i>	29
<i>Sex</i>	Male
<i>BAC Driver</i>	0 %
<i>Driving Experience</i>	Unknown
<i>Licence Type</i>	Unknown
<i>Driver Action</i>	Braked before impact

Impact Vehicle Details

<i>Vehicle Model</i>	1988 Toyota Hilux utility	<i>Impact Point</i>	1
<i>Type</i>	Car derivative		
<i>Number Involved</i>	1		
<i>Modifications</i>	None		

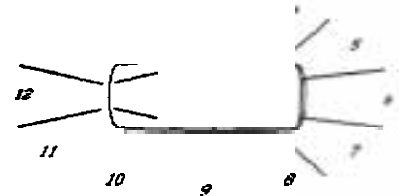

Road Site Details

<i>Traffic Control</i>	None	<i>Road Type</i>	Other main traffic route
<i>Traffic Conditions</i>	Light		
<i>Weather Conditions</i>	Fine, dry road	<i>Road Alignment</i>	Straight
<i>Number of Lanes</i>	1	<i>Natural Lighting</i>	Day
<i>Road Division</i>	Centre line	<i>Street Lighting</i>	Not applicable

Reduced Travel Speed Analysis

	5 km/hr reduction	10 km/hr reduction	10% reduction	20% reduction
Travel Speed (km/hr)	45	40	45	40
Impact Speed (km/hr)	28	0	28	0

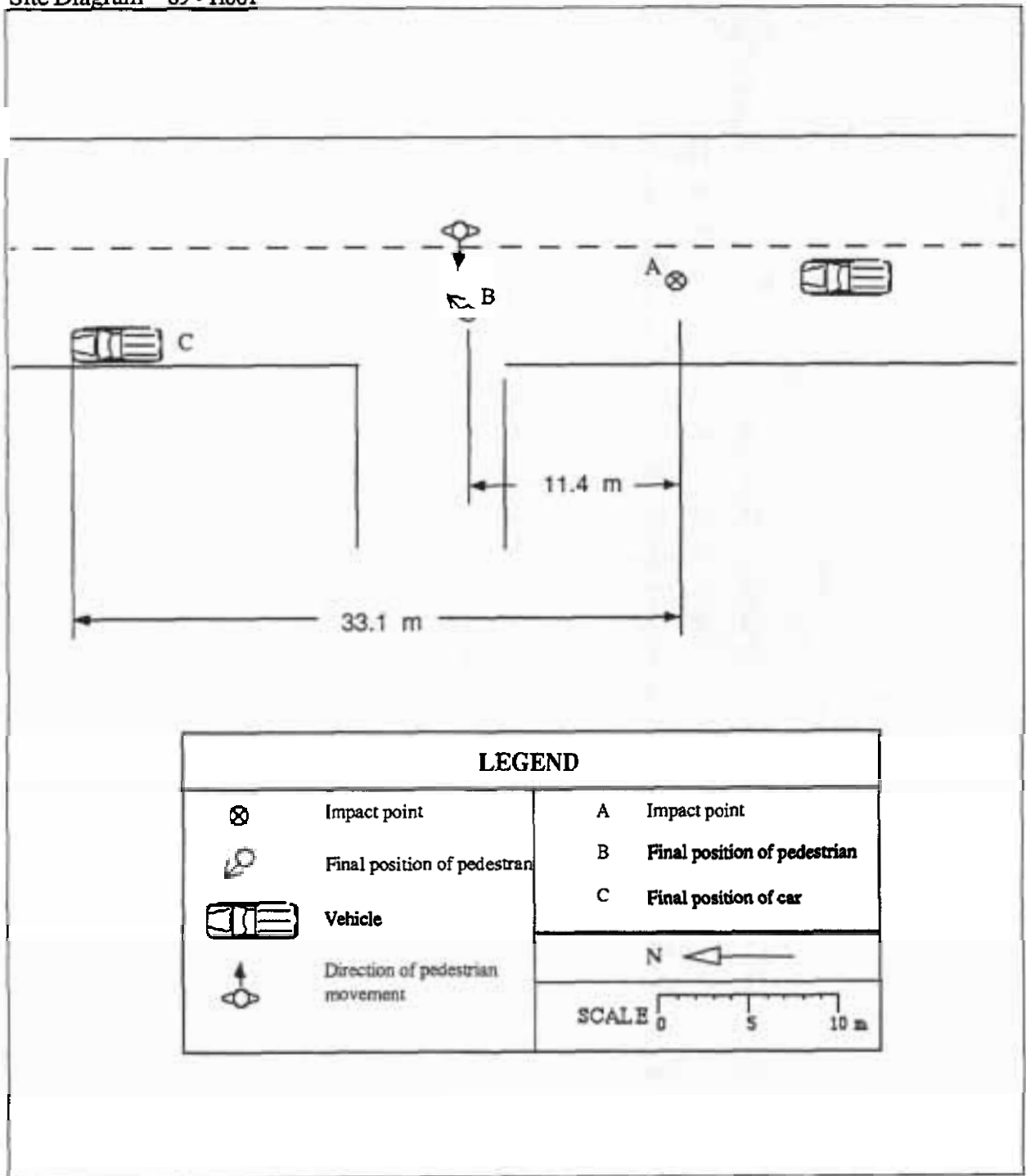

Accident Description

The vehicle was travelling in a northerly direction at 50 km/hr about 1 metre from the centre line. The driver estimated that he saw the pedestrian 20 yards away about 3 yards to the east of the centre line. The driver thought the pedestrian would stop on the centre line but the pedestrian continued walking and collided with the vehicle at point A. The pedestrian was struck on his left hand side by the right front of the the vehicle. He then rolled onto the bonnet and fell to the road off the right side, coming to rest at point D. The vehicle continued and stopped at point C.

Case Details

<i>Case Number</i>	89 - H002	<i>Calculation type</i>	2.1
<i>Date of Accident</i>	Friday, January	<i>Time</i>	3 pm
<i>Speed Limit</i>	60 km/hr	<i>Number of Pedestrians Involved</i>	1
<i>Travel Speed</i>	73 km/hr	<i>Travel Speed Source</i>	Skid marks
<i>Impact Speed</i>	38 km/hr	<i>Impact Speed Source</i>	Skid marks

Pedestrian Details

<i>Fatal</i>	Yes
<i>Age</i>	5
<i>Sex</i>	Male
<i>BAC Pedestrian</i>	0 %
<i>Action</i>	Running
<i>Movement</i>	Crossing the road
<i>Side Impacted</i>	Left side to vehicle

Driver Details

<i>Age</i>	50
<i>Sex</i>	Male
<i>BAC Driver</i>	0 %
<i>Driving Experience</i>	34 years
<i>Licence Type</i>	Full
<i>Driver Action</i>	Braked before impact

Impact Vehicle Details

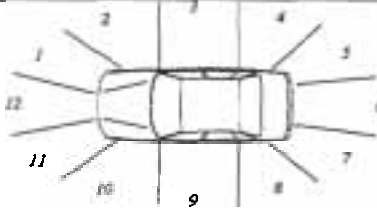
<i>Vehicle Model</i>	1972 Chrysler sedan	<i>Impact Point</i>	11	
<i>Type</i>	Car			
<i>Number Involved</i>	1			
<i>Modifications</i>	None			





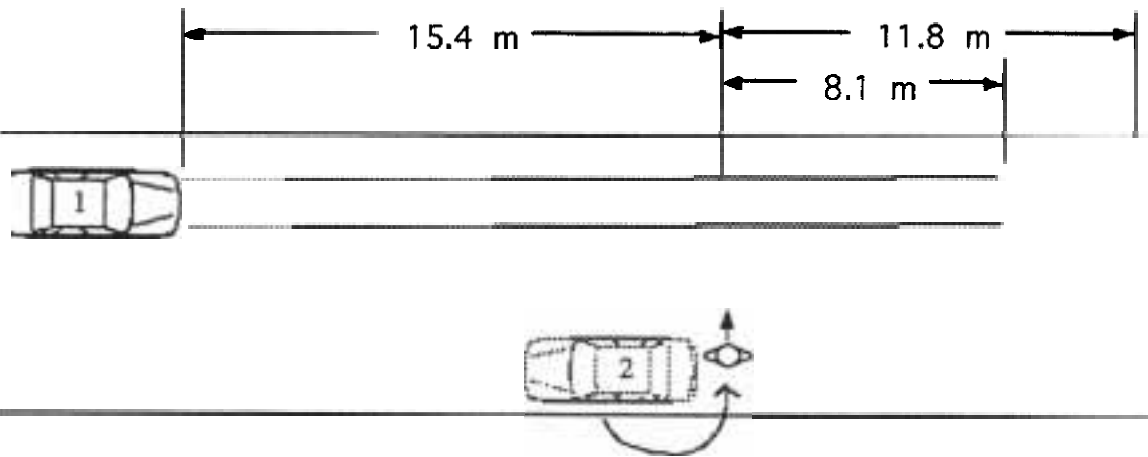

Road Site Details

<i>Traffic Control</i>	None	<i>Road Type</i>	Local street
<i>Traffic Conditions</i>	Light	<i>Road Alignment</i>	Straight
<i>Weather Conditions</i>	Fine, dry road	<i>Natural Lighting</i>	Day
<i>Number of Lanes</i>	1	<i>Street Lighting</i>	Not applicable
<i>Road Division</i>	None		

Reduced Travel Speed Analysis

	5 km/hr	10 km/hr	10%	20%
Travel Speed (km/hr)	68	63	66	59
Impact Speed (km/hr)	20	0	0	0



LEGEND									
	Impact point								
	Final position of pedestrian								
	Vehicle1								
	Parked Vehicle2								
	Direction of pedestrian movement								
<table border="1"> <tr> <td>SCALE</td> <td>0</td> <td>1</td> <td>2</td> <td>3</td> <td>4</td> <td>5</td> <td>m</td> </tr> </table>		SCALE	0	1	2	3	4	5	m
SCALE	0	1	2	3	4	5	m		
 N									

Accident Description

Vehicle 1 was travelling in a northerly direction at 73 km/hr. The pedestrian ran in a westerly direction from behind Vehicle 2 parked by the eastern kerb. The driver saw him stop in the middle of the road as someone called out, but he then ran in front of the Vehicle 1 and was hit at point A. The pedestrian was struck on his left hand side by the left side of the front of the car. He was then thrown forward and slid along the road, coming to rest at point B.

Case Details

<i>Case Number</i>	89- H005	<i>Calculation type</i>	2.1
<i>Date of Accident</i>	Thursday, January	<i>Time</i>	10 am
<i>Speed Limit</i>	60 km/hr	<i>Number of Pedestrians Involved</i>	1
<i>Travel Speed</i>	70 km/hr	<i>Travel Speed Source</i>	Skid marks
<i>Impact Speed</i>	59 km/hr	<i>Impact Speed Source</i>	Skid marks

Pedestrian Details

<i>Fatal</i>	Yes
<i>Age</i>	53
<i>Sex</i>	Male
<i>BAC Pedestrian</i>	0 %
<i>Action</i>	Walking
<i>Movement</i>	At road works
<i>Side Impacted</i>	Right side to vehicle

Driver Details

<i>Age</i>	67
<i>Sex</i>	Male
<i>BAC Driver</i>	0 %
<i>Driving Experience</i>	55 years
<i>Licence Type</i>	Full
<i>Driver Action</i>	Braked before impact

Impact Vehicle Details

<i>Vehicle Model</i>	1974 Dodge utility towing trailer	<i>Impact Point</i>	11
<i>Type</i>	Car derivative		
<i>Number Involved</i>	1		
<i>Modifications</i>	None		

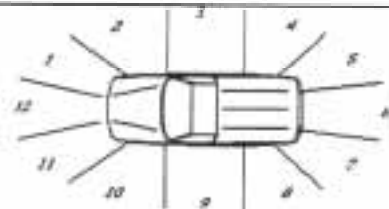

Road Site Details

<i>Traffic Control</i>	None	<i>Road Type</i>	Arterial
<i>Traffic Conditions</i>	Moderate	<i>Road Alignment</i>	Straight
<i>Weather Conditions</i>	Fine, dry road	<i>Natural Lighting</i>	Day
<i>Number of Lanes</i>	2	<i>Street Lighting</i>	None
<i>Road Division</i>	Raised median strip		

Reduced Travel Speed Analysis

	5 km/hr reduction	10 km/hr reduction	10% reduction	20% reduction
Travel Speed (km/hr)	65	60	63	56
Impact Speed (km/hr)	52	45	50	38

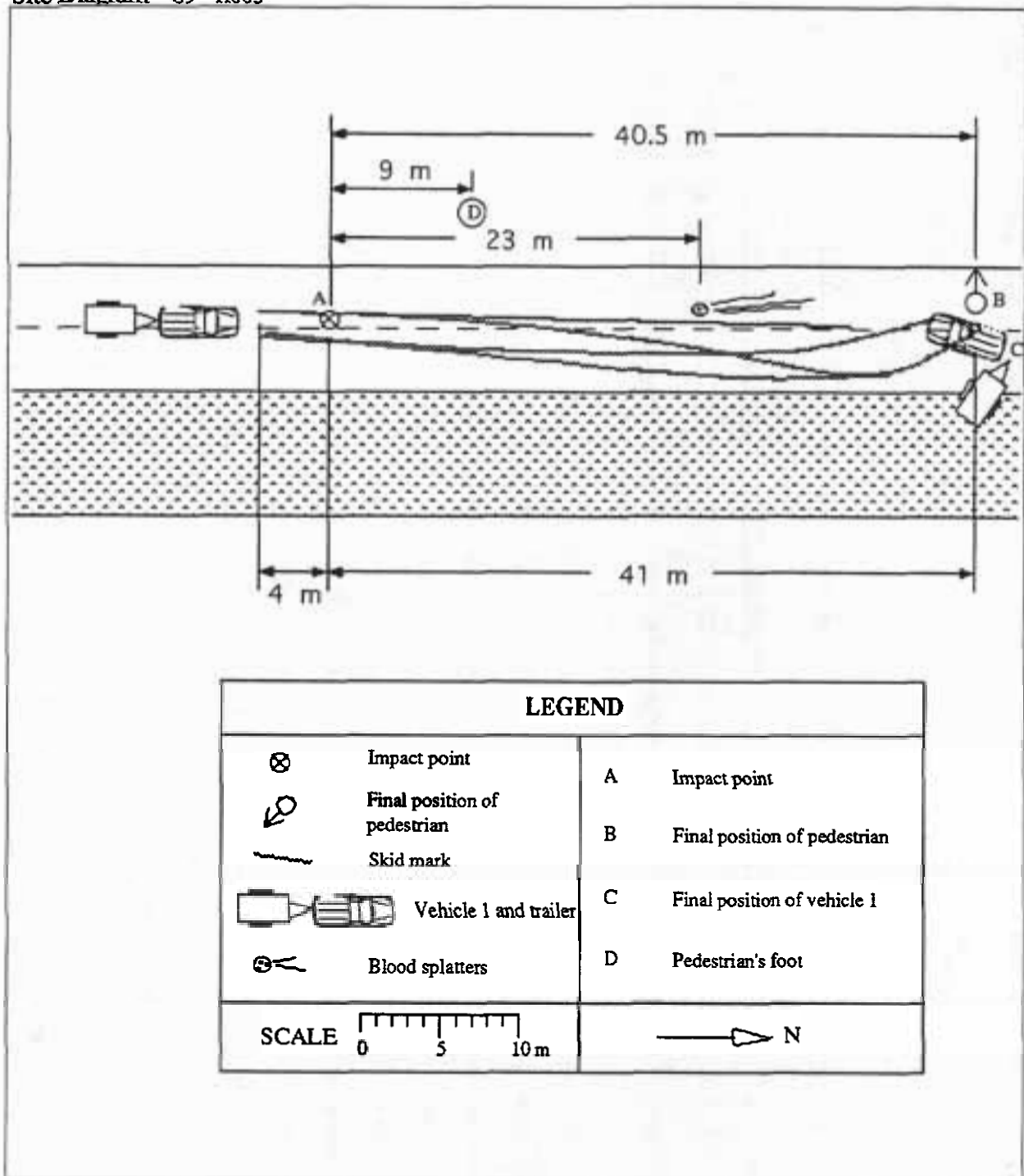

Accident Description

The vehicle, a utility towing a trailer, was travelling in a northerly direction at a speed calculated from skid marks to have been 70 km/hr. The vehicle was approaching roadworks at which there was a temporary speed limit of 60 km/hr. The pedestrian was walking inside the coned off area of the road works. Vehicle 2 was in front of Vehicle 1 and the driver states that he was hailed to slow down further by the pedestrian. It appears that the driver of vehicle 1 was not aware of the reduction in speed and swerved left sharply to avoid colliding with Vehicle 2. On moving to the left he crossed into the roadworks area and the pedestrian was directly in his path. He applied his brakes, locking up the wheels and collided with the pedestrian at point A. The pedestrian's movements and orientation before the impact are unknown. From the injuries obtained the pedestrian was probably hit on his right side and hit the A pillar and windscreen with his head. He was then thrown over the roof and fell off the left side and rolled along the road coming to rest at point B. The pedestrian's right foot was amputated during the collision and this was found at point D. The car skidded to a complete stop at point C, rotating nearly 180 degrees in the process.

Case Details

<i>Case Number</i>	89 - H014	<i>Calculation type</i>	2.1
<i>Date of Accident</i>	Saturday, March	<i>Time</i>	12 pm
<i>Speed Limit</i>	80 km/hr	<i>Number of Pedestrians Involved</i>	1
<i>Travel Speed</i>	79 km/hr	<i>Travel Speed Source</i>	Skid marks
<i>Impact Speed</i>	15 km/hr	<i>Impact Speed Source</i>	Skid marks

<i>Fatal</i>	Yes
<i>Age</i>	73
<i>Sex</i>	Female
<i>BAC Pedestrian</i>	0 %
<i>Action</i>	Standing
<i>Movement</i>	Crossing the road
<i>Side Impacted</i>	Right side to vehicle

<i>Age</i>	21
<i>Sex</i>	Male
<i>BAC Driver</i>	0 %
<i>Driving Experience</i>	5 years
<i>Licence Type</i>	Full
<i>Driver Action</i>	Braked before impact



Road Site Details

<i>Traffic Control</i>	None	<i>Road Type</i>	Arterial
<i>Traffic Conditions</i>	Moderate	<i>Road Alignment</i>	Curved
<i>Weather Conditions</i>	Fine, dry road	<i>Natural Lighting</i>	Day
<i>Number of Lanes</i>	3	<i>Street Lighting</i>	Not applicable
<i>Road Division</i>	Raised median strip		

Reduced Travel Speed Analysis

	5 km/hr reduction	10 km/hr reduction	10% reduction	20% reduction
Travel Speed (km/hr)	74	69	71	63
Impact Speed (km/hr)	0	0	0	0

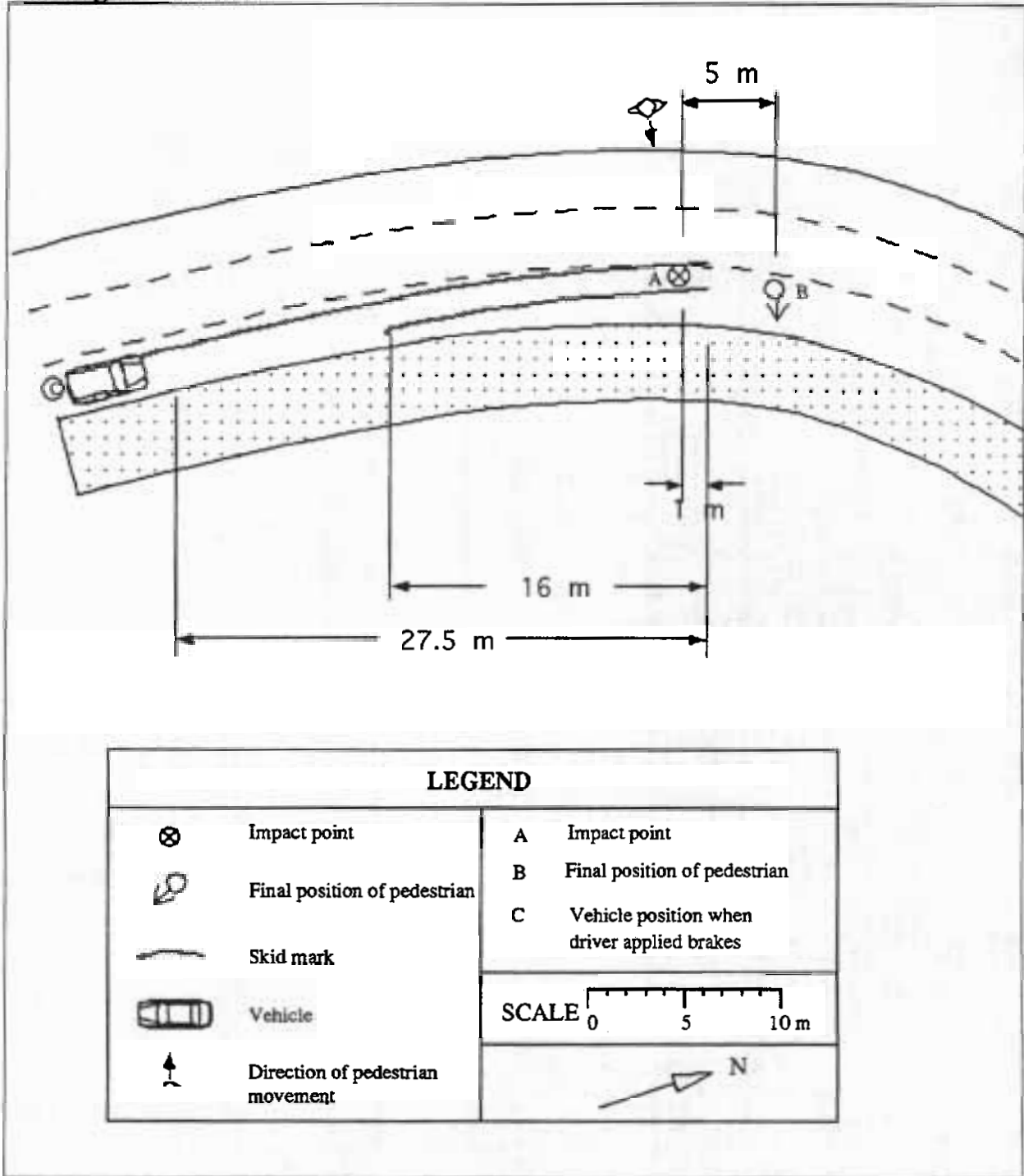

Accident Description

The car was travelling north in the right hand lane at a calculated speed of 79 km/hr. The pedestrian was crossing the road in an easterly direction at a curve in the road. The driver and several witnesses stated she was not looking to her right for oncoming traffic. The vehicle was about 40 metres away when the driver saw the pedestrian (driver estimation). He sounded his horn and braked, locking up the wheels at point C. The pedestrian looked to her right and 'froze' in her position. The vehicle struck the pedestrian at point A. The right side of the front of the car struck the right side of the pedestrian causing her to roll up onto the bonnet and her head impact the base of the windscreen (which shattered). She came to rest at point B. The driver stopped the car and parked on the median strip.

Case Details

<i>Case Number</i>	89 - H020	<i>Calculation type</i>	1
<i>Date of Accident</i>	Tuesday, April	<i>Time</i>	7 am
<i>Speed Limit</i>	60 km/hr	<i>Number of Pedestrians Involved</i>	1
<i>Travel Speed</i>	60 km/hr	<i>Travel Speed Source</i>	Driver
<i>Impact Speed</i>	60 km/hr	<i>Impact Speed Source</i>	Driver

<i>Fatal</i>	Yes	<i>Age</i>	36
<i>Age</i>	80	<i>Sex</i>	Male
<i>Sex</i>	Female	<i>BAC Driver</i>	0 %
<i>BAC Pedestrian</i>	0 %	<i>Driving Experience</i>	17 years
<i>Action</i>	Walking	<i>Licence Type</i>	Full
<i>Movement</i>	Crossing the road	<i>Driver Action</i>	Braked after impact
<i>Side Impacted</i>	Left side to vehicle		

Impact Vehicle Details

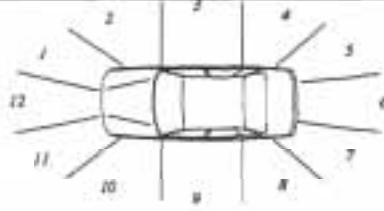
<i>Vehicle Model</i>	1963 Ford Falcon sedan	
<i>Type</i>	Car	
<i>Number Involved</i>	1	
<i>Modifications</i>	None	

Road Site Details

<i>Traffic Control</i>	None	<i>Road Type</i>	Arterial
<i>Traffic Conditions</i>	Moderate	<i>Road Alignment</i>	Curved
<i>Weather Conditions</i>	Fine, wet road	<i>Natural Lighting</i>	Day
<i>Number of Lanes</i>	1	<i>Street Lighting</i>	Not applicable
<i>Road Division</i>	Centre line		

Reduced Travel Speed Analysis

	5 km/hr reduction	10 km/hr reduction	10% reduction	20% reduction
Travel Speed (km/hr)	55	50	54	48
Impact Speed (km/hr)	55	50	54	48

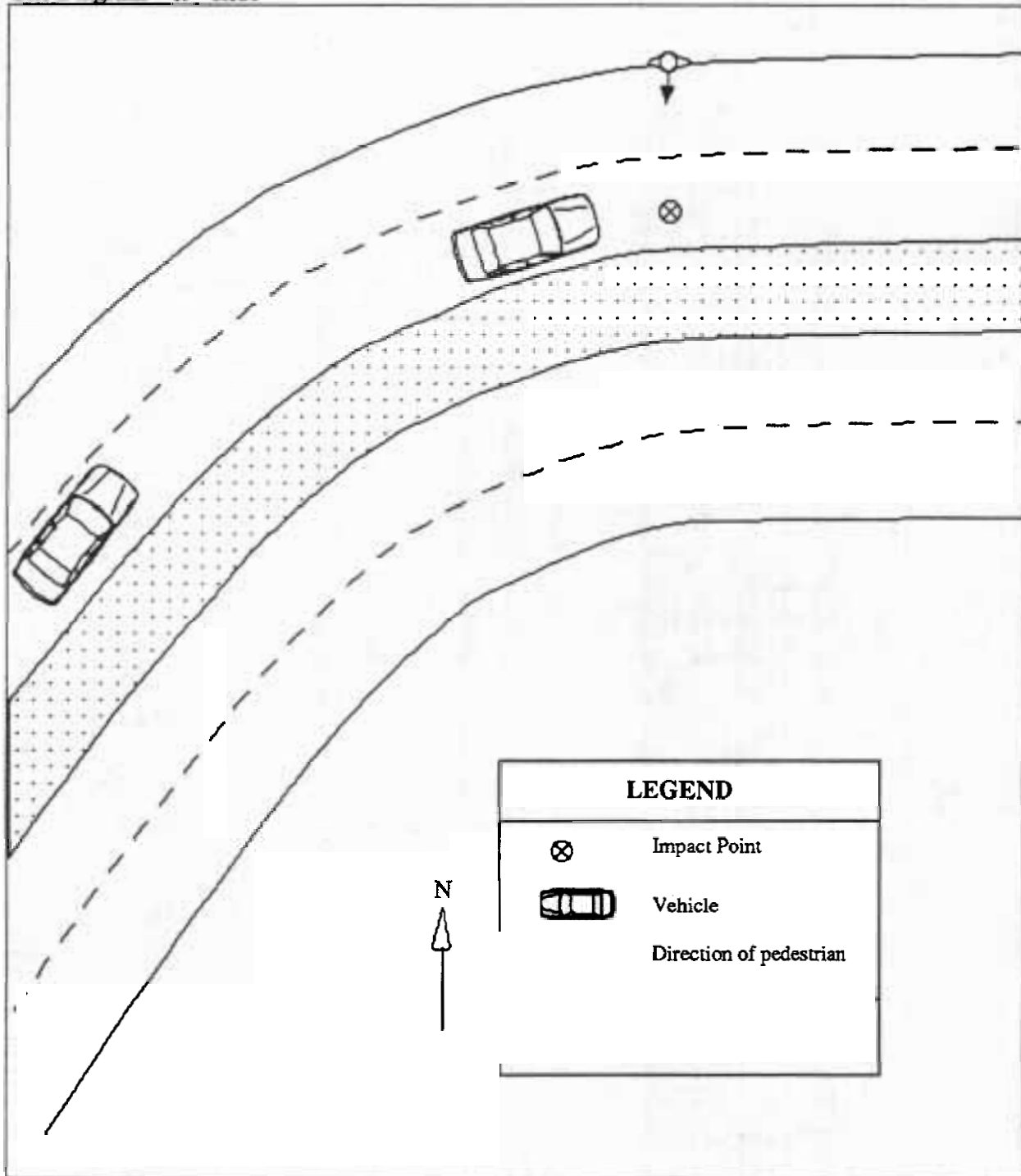

Accident Description

The pedestrian was walking in a southerly direction across the road. The car was travelling north heading towards the bend at about 60 km/hr. The driver stated that after negotiating the bend, his view was obscured by bright sunlight and he collided with the pedestrian. The driver also stated that he had not seen the pedestrian prior to the collision and was only able to apply the brakes after the collision. The pedestrian was struck by the right front corner of the car. The final positions of the car and pedestrian are unknown.

Case Details

<i>Case Number</i>	89 - H026	<i>Calculation type</i>	1
<i>Date of Accident</i>	Saturday, July	<i>Time</i>	12 am
<i>Speed Limit</i>	60 km/hr	<i>Number of Pedestrians Involved</i>	1
<i>Travel Speed</i>	62 km/hr	<i>Travel Speed Source</i>	Skid marks
<i>Impact Speed</i>	62 km/hr	<i>Impact Speed Source</i>	Skid marks

Pedestrian Details

<i>Fatal</i>	Yes
<i>Age</i>	22
<i>Sex</i>	Male
<i>BAC Pedestrian</i>	0.169 %
<i>Action</i>	Walking
<i>Movement</i>	Along the road
<i>Side Impacted</i>	Back to vehicle

Driver Details

<i>Age</i>	33
<i>Sex</i>	Male
<i>BAC Driver</i>	0.116 %
<i>Driving Experience</i>	16 years
<i>Licence Type</i>	Full
<i>Driver Action</i>	Braked after impact

Impact Vehicle Details

<i>Vehicle Model</i>	1976 Ford XB station wagon	<i>Impact Point</i>	12
<i>Type</i>	Car		
<i>Number Involved</i>	1		
<i>Modifications</i>	None		

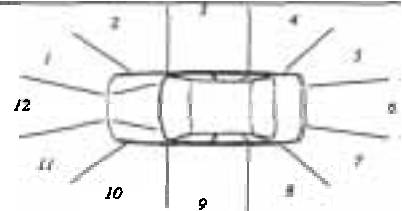

Road Site Details

<i>Traffic Control</i>	None	<i>Road Type</i>	Arterial
<i>Traffic Conditions</i>	Light	<i>Road Alignment</i>	Straight
<i>Weather Conditions</i>	Fine, dry road	<i>Natural Lighting</i>	Night
<i>Number of Lanes</i>	1	<i>Street Lighting</i>	Street lights
<i>Road Division</i>	Centre line		

Reduced Travel Speed Analysis

	5 km/hr reduction	10 km/hr reduction	10% reduction	20% reduction
Travel Speed (km/hr)	57	52	56	50
Impact Speed (km/hr)	57	52	56	50

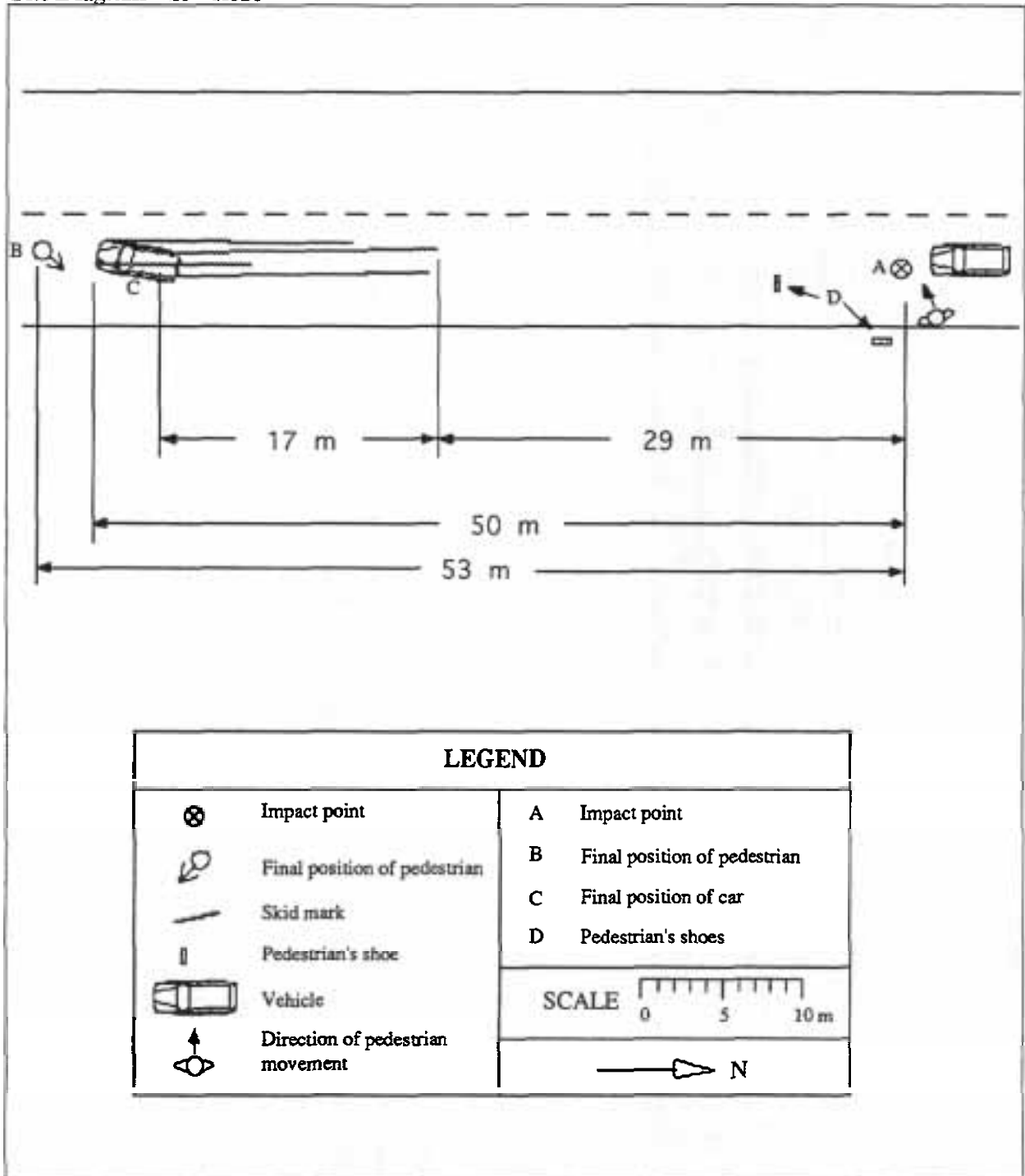

Accident Description

The car was travelling in a southerly direction at about 62 km/hr. The pedestrian was walking in a southerly direction in the middle of the southbound lane. The driver said that he came over the crest of the hill and the pedestrian was in front of him. He had no time to avoid the accident and impact occurred at point A. The pedestrian was struck from the rear by the left side of the front of the car, causing him to roll up and impact the the top of the bonnet. He then fell off to the left, rolling forward on the road to point B. The car stopped at point C.

Case Details

<i>Case Number</i>	89 - H029	<i>Calculation type</i>	1
<i>Date of Accident</i>	Tuesday, August	<i>Time</i>	7 pm
<i>Speed Limit</i>	60 km/hr	<i>Number of Pedestrians Involved</i>	1
<i>Travel Speed</i>	60 km/hr	<i>Travel Speed Source</i>	Driver
<i>Impact Speed</i>	60 km/hr	<i>Impact Speed Source</i>	Driver

Pedestrian Details

<i>Fatal</i>	Yes
<i>Age</i>	87
<i>Sex</i>	Male
<i>BAC Pedestrian</i>	0.171 %
<i>Action</i>	Walking
<i>Movement</i>	Crossing the road
<i>Side Impacted</i>	Left side to vehicle

Driver Details

<i>Age</i>	35
<i>Sex</i>	Male
<i>BAC Driver</i>	0 %
<i>Driving Experience</i>	Unknown
<i>Licence Type</i>	Full
<i>Driver Action</i>	Braked after impact

Impact Vehicle Details

<i>Vehicle Model</i>	1976 Datsun Bluebird station wagon
<i>Type</i>	<i>Impact Point</i> 12
<i>Number Involved</i>	1
<i>Modifications</i>	None

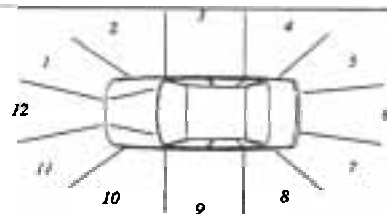

Road Site Details

<i>Traffic Control</i>	Pedestrian operated traffic signals	<i>Road Type</i>	Arterial
<i>Traffic Conditions</i>	Light	<i>Road Alignment</i>	Straight
<i>Weather Conditions</i>	Raining	<i>Natural Lighting</i>	Night
<i>Number of Lanes</i>	1	<i>Street Lighting</i>	Street lights
<i>Road Division</i>	Painted median strip		

	5 km/hr reduction	10 km/hr reduction	10% reduction	20% reduction
Travel Speed (km/hr)	55	50	54	48
Impact Speed (km/hr)	55	50	54	48

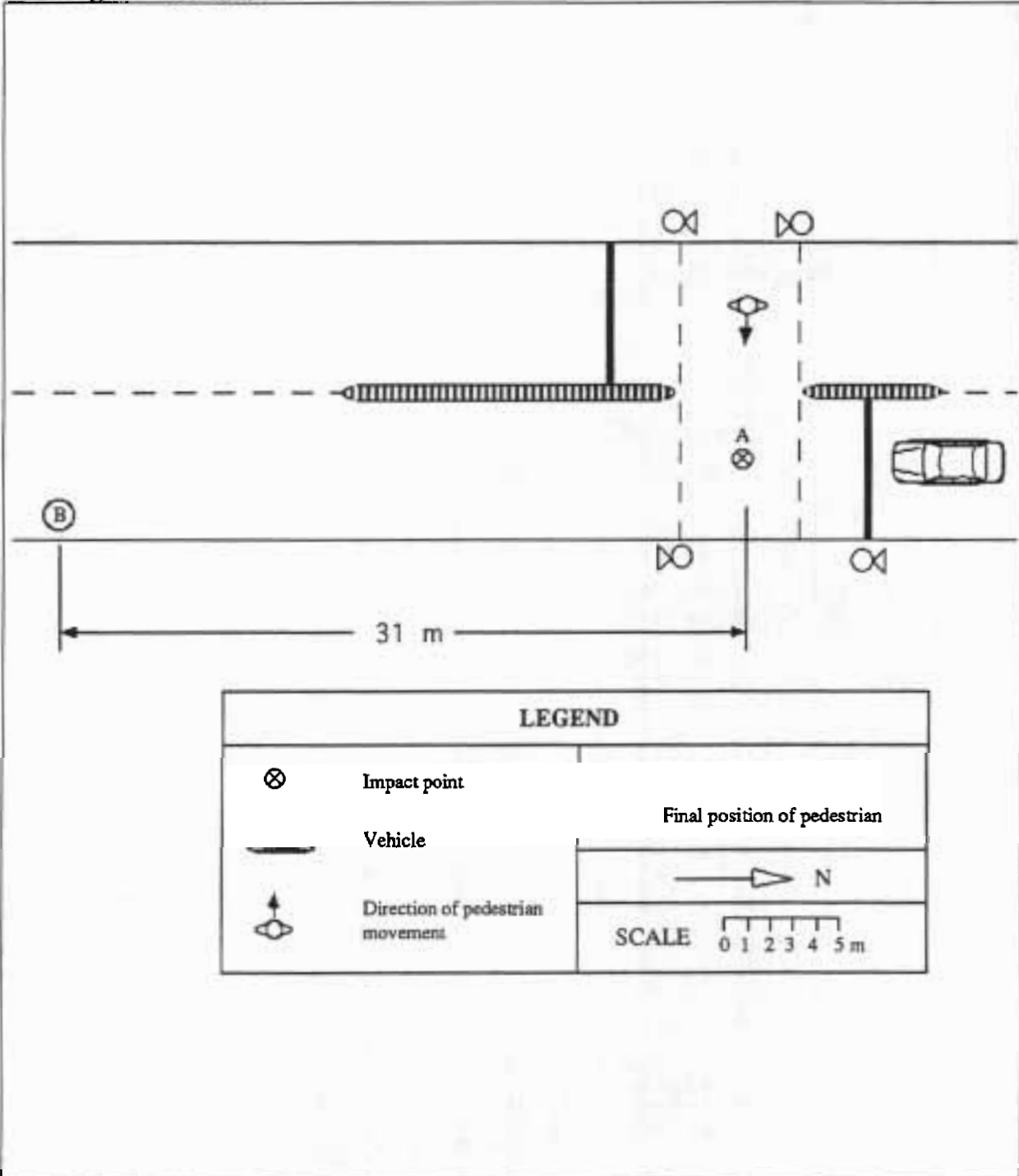

Accident Description

The car was travelling in a southerly direction at 60 km/hr. It was raining very hard and as the driver approached the pedestrian crossing he saw a shadow in front of him and then he hit the pedestrian who was crossing the road in an easterly direction. The driver states that the lights were green for cars at the time of the accident and that they did not change at any time after the accident. The pedestrian was struck on his left hand side by the centre of the front of the car, he then rolled up and struck his head on the bonnet and was thrown over the roof and off to the left. He came to rest at point B. The driver stopped his vehicle further down the road.

Case Details

<i>Case Number</i>	89 - H033	<i>Calculation type</i>	1
<i>Date of Accident</i>	Saturday, September	<i>Time</i>	12 am
<i>Speed Limit</i>	60 km/hr	<i>Number of Pedestrians Involved</i>	1
<i>Travel Speed</i>	65 km/hr	<i>Travel Speed Source</i>	Driver
<i>Impact Speed</i>	65 km/hr	<i>Impact Speed Source</i>	Driver

Pedestrian Details

<i>Fatal</i>	Yes
<i>Age</i>	42
<i>Sex</i>	Male
<i>BAC Pedestrian</i>	0 %
<i>Action</i>	Standing
<i>Movement</i>	Other
<i>Side Impacted</i>	Facing vehicle

Driver Details

<i>Age</i>	26
<i>Sex</i>	Male
<i>BAC Driver</i>	0 %
<i>Driving Experience</i>	9 years
<i>Licence Type</i>	Full
<i>Driver Action</i>	Braked after impact

Impact Vehicle Details

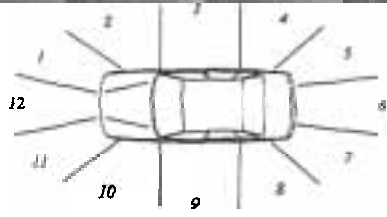
<i>Vehicle Model</i>	1984 Toyota Corolla sedan	<i>Impact Point</i>	1	
<i>Type</i>	Car			
<i>Number Involved</i>	1			
<i>Modifications</i>	None			

Road Site Details

<i>Traffic Control</i>	None	<i>Road Type</i>	Local street
<i>Traffic Conditions</i>	Light	<i>Road Alignment</i>	Straight
<i>Weather Conditions</i>	Fine, dry road	<i>Natural Lighting</i>	Night
<i>Number of Lanes</i>	1	<i>Street Lighting</i>	Street lights
<i>Road Division</i>	None		

Reduced Travel Speed Analysis

	5 km/hr reduction	10 km/hr reduction	10% reduction	20% reduction
Travel Speed (km/hr)	60	55	59	52
Impact Speed (km/hr)	60	55	59	52

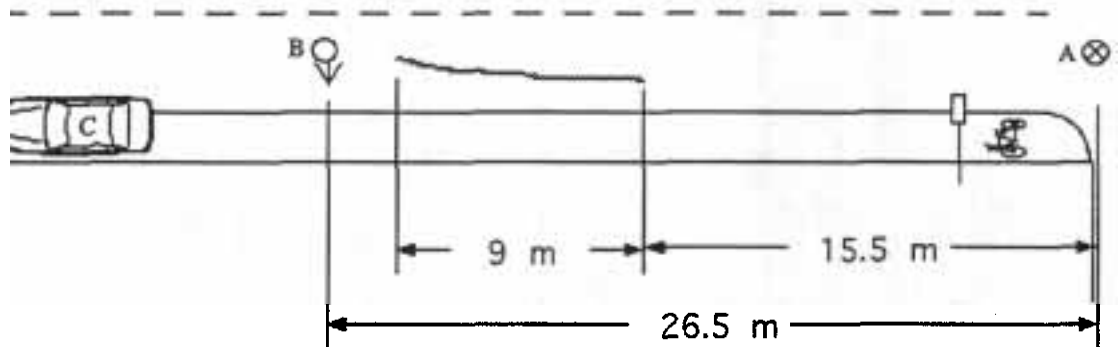

LEGEND			
	Impact point	A	Impact point
	Final position of pedestrian	B	Final position of pedestrian
	Vehicle	C	Car position on Police arrival
	Direction of pedestrian movement	N	
	Street light	SCALE	
	Skid mark		

Accident Description

The car was travelling in a southerly direction at 65 km/hr. The pedestrian was standing on the road facing in a northerly direction. The driver of the vehicle did not see the pedestrian until he hit him (point A). The pedestrian was struck front on by the right side of the front of the car near the headlights. His head then struck the plenum, and he fell off to the right side of the car coming to rest at point B. The driver braked hard at impact and one tyre locked up, leaving a skid mark. After stopping the driver then pulled his car to the side of the road at point C.

Case Details

<i>Case Number</i>	89 - H031	<i>Calculation type</i>	1
<i>Date of Accident</i>	Saturday, August	<i>Time</i>	5 am
<i>Speed Limit</i>	60 km/hr	<i>Number of Pedestrians Involved</i>	1
<i>Travel Speed</i>	50 km/hr	<i>Travel Speed Source</i>	Driver
<i>Impact Speed</i>	50 km/hr	<i>Impact Speed Source</i>	Driver

Pedestrian Details

<i>Fatal</i>	Yes
<i>Age</i>	28
<i>Sex</i>	Male
<i>BAC Pedestrian</i>	0.246 %
<i>Action</i>	Walking
<i>Movement</i>	Crossing the road
<i>Side Impacted</i>	Right side to vehicle

Driver Details

<i>Age</i>	24
<i>Sex</i>	Male
<i>BAC Driver</i>	0.143 %
<i>Driving Experience</i>	8 years
<i>Licence Type</i>	Probationary
<i>Driver Action</i>	Braked after impact

Impact Vehicle Details

<i>Vehicle Model</i>	1986 Toyota Corolla sedan
<i>Type</i>	Impact Point 12
<i>Number Involved</i>	1
<i>Modifications</i>	None

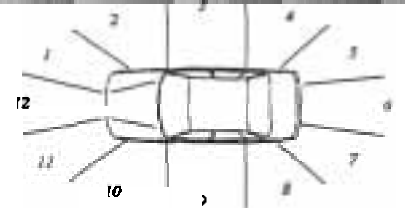

Road Site Details

<i>Traffic Control</i>	Pedestrian operated traffic signals	<i>Road Type</i>	Arterial
<i>Traffic Conditions</i>	Light	<i>Road Alignment</i>	Straight
<i>Weather Conditions</i>	Fine, wet road	<i>Natural Lighting</i>	Night
<i>Number of Lanes</i>	3	<i>Street Lighting</i>	Street lights
<i>Road Division</i>	Raised median strip		

Reduced Travel Speed Analysis

	5 km/hr reduction	10 km/hr reduction	10% reduction	20% reduction
Travel Speed (km/hr)	45	40	45	40
Impact Speed (km/hr)	45	40	45	40

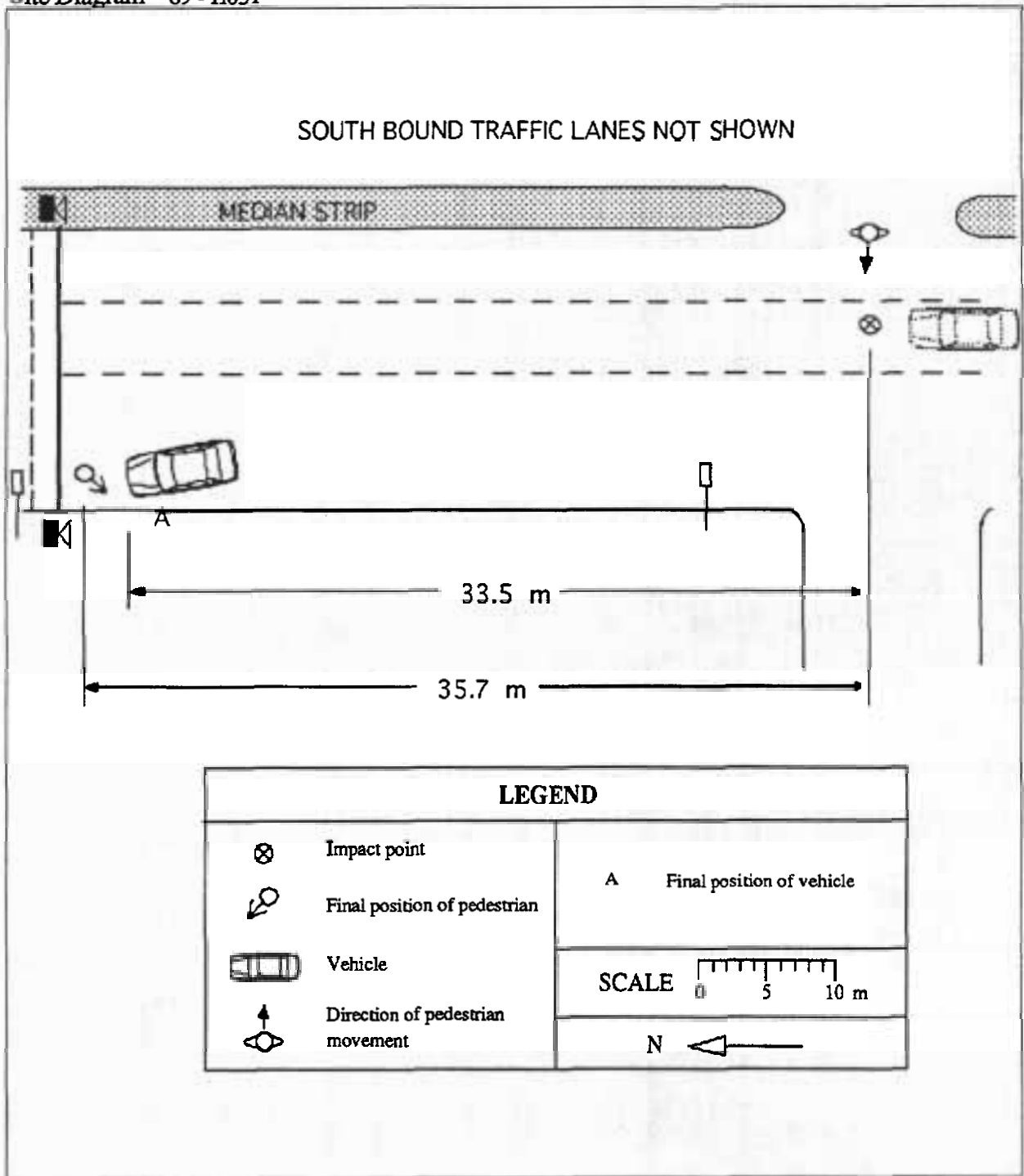

Accident Description

The car was travelling north in the lane nearest the centre of the road at about 50 km/hr. The driver stated that he did not see the pedestrian prior to the collision and did not take any evasive action. Pedestrian movements prior to the impact are unknown. However the driver believes that the pedestrian must have been crossing the road from west to east. The pedestrian was struck by the front left of the vehicle and then by the windscreen.

Case Details

<i>Case Number</i>	89 - H032	<i>Calculation type</i>	2.2
<i>Date of Accident</i>	Thursday, September	<i>Time</i>	9 pm
<i>Speed Limit</i>	60 km/hr	<i>Number of Pedestrians Involved</i>	1
<i>Travel Speed</i>	55 km/hr	<i>Travel Speed Source</i>	Witness
<i>Impact Speed</i>	21 km/hr	<i>Impact Speed Source</i>	Skid marks

Pedestrian Details

<i>Fatal</i>	Yes
<i>Age</i>	80
<i>Sex</i>	Male
<i>BAC Pedestrian</i>	0 %
<i>Action</i>	Walking
<i>Movement</i>	Crossing the road
<i>Side Impacted</i>	Left side to vehicle

Driver Details

<i>Age</i>	19
<i>Sex</i>	Male
<i>BAC Driver</i>	0 %
<i>Driving Experience</i>	2 years
<i>Licence Type</i>	Full
<i>Driver Action</i>	Braked before impact

Impact Vehicle Details

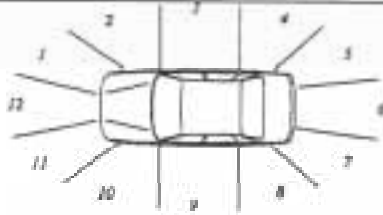
<i>Vehicle Model</i>	1972 Holden Monaro sedan	
<i>Type</i>	Car	
<i>Impact Point</i>	2	
<i>Number Involved</i>	1	
<i>Modifications</i>	None	

Road Site Details

<i>Traffic Control</i>	None	<i>Road Type</i>	Arterial
<i>Traffic Conditions</i>	Light	<i>Road Alignment</i>	Straight
<i>Weather Conditions</i>	Fine, dry road	<i>Natural Lighting</i>	Night
<i>Number of Lanes</i>	2	<i>Street Lighting</i>	Street lights
<i>Road Division</i>	Centre line		

Reduced Travel Speed Analysis

	5 km/hr reduction	10 km/hr reduction	10% reduction	20% reduction
Travel Speed (km/hr)	50	45	50	44
Impact Speed (km/hr)	0	0	0	0

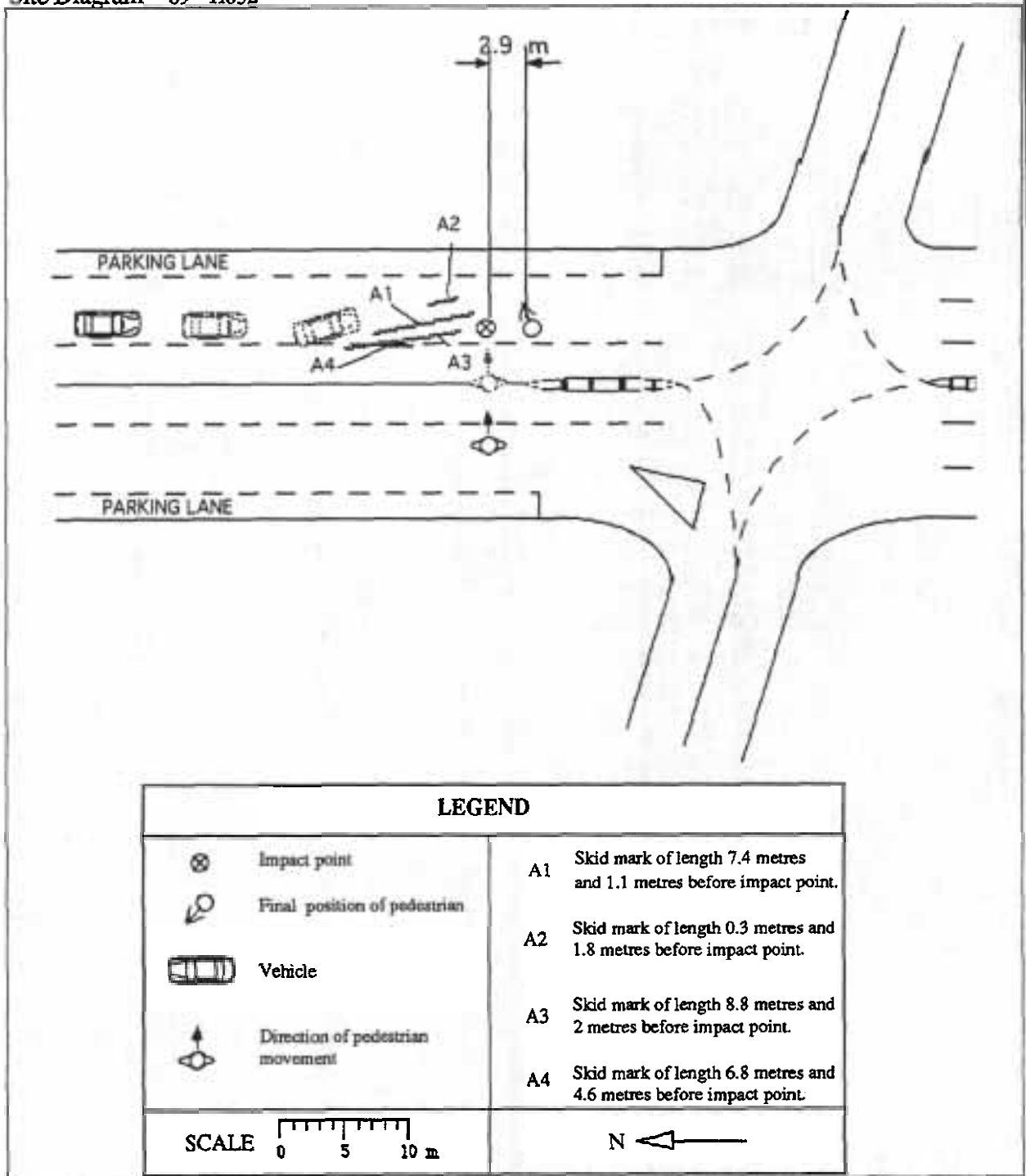

Accident Description

Vehicle 1 was travelling south when it collided with a pedestrian walking across the road in a easterly direction. The driver stated that he was driving in the left lane at a speed of about 40 km/hr and saw the pedestrian about 30 to 35 metres away in the centre of the road. The driver then stated that about 10 metres from the pedestrian, he saw the pedestrian walk east into the path of his vehicle. At this time the driver was slowing down and locked up the brakes to avoid the collision. The pedestrian collided with the right hand side of the vehicle. A witness stated that the vehicle speed was around 45 to 55 km/hr.

Case Details

<i>Case Number</i>	89 - H034	<i>Calculation type</i>	3.1
<i>Date of Accident</i>	Tuesday, September	<i>Time</i>	7 pm
<i>Speed Limit</i>	80 km/hr	<i>Number of Pedestrians Involved</i>	1
<i>Travel Speed</i>	75 km/hr	<i>Travel Speed Source</i>	Driver
<i>Impact Speed</i>	72 km/hr	<i>Impact Speed Source</i>	Projection distance

Pedestrian Details

<i>Fatal</i>	Yes
<i>Age</i>	36
<i>Sex</i>	Male
<i>BAC Pedestrian</i>	0.134 %
<i>Action</i>	Walking
<i>Movement</i>	Crossing the road
<i>Side Impacted</i>	Left side to vehicle

Driver Details

<i>Age</i>	61
<i>Sex</i>	Male
<i>BAC Driver</i>	0 %
<i>Driving Experience</i>	31 years
<i>Licence Type</i>	Full
<i>Driver Action</i>	Braked after impact

Impact Vehicle Details

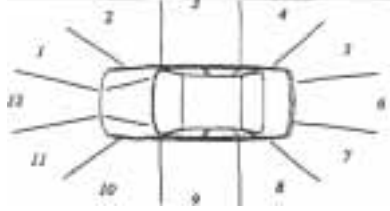
<i>Vehicle Model</i>	1974 Honda Civic sedan		
<i>Type</i>	Car		<i>Impact Point</i> 12
<i>Number Involved</i>	2		
<i>Modifications</i>	None		

Road Site Details

<i>Traffic Control</i>	None	<i>Road Type</i>	Arterial
<i>Traffic Conditions</i>	Light	<i>Road Alignment</i>	Straight
<i>Weather Conditions</i>	Fine, dry road	<i>Natural Lighting</i>	Night
<i>Number of Lanes</i>	2	<i>Street Lighting</i>	Street lights
<i>Road Division</i>	Raised median strip		

Reduced Travel Speed Analysis

	5 km/hr	10 km/hr	10%	20%
Travel Speed (km/hr)	70	65	68	60
Impact Speed (km/hr)	63	52	57	38

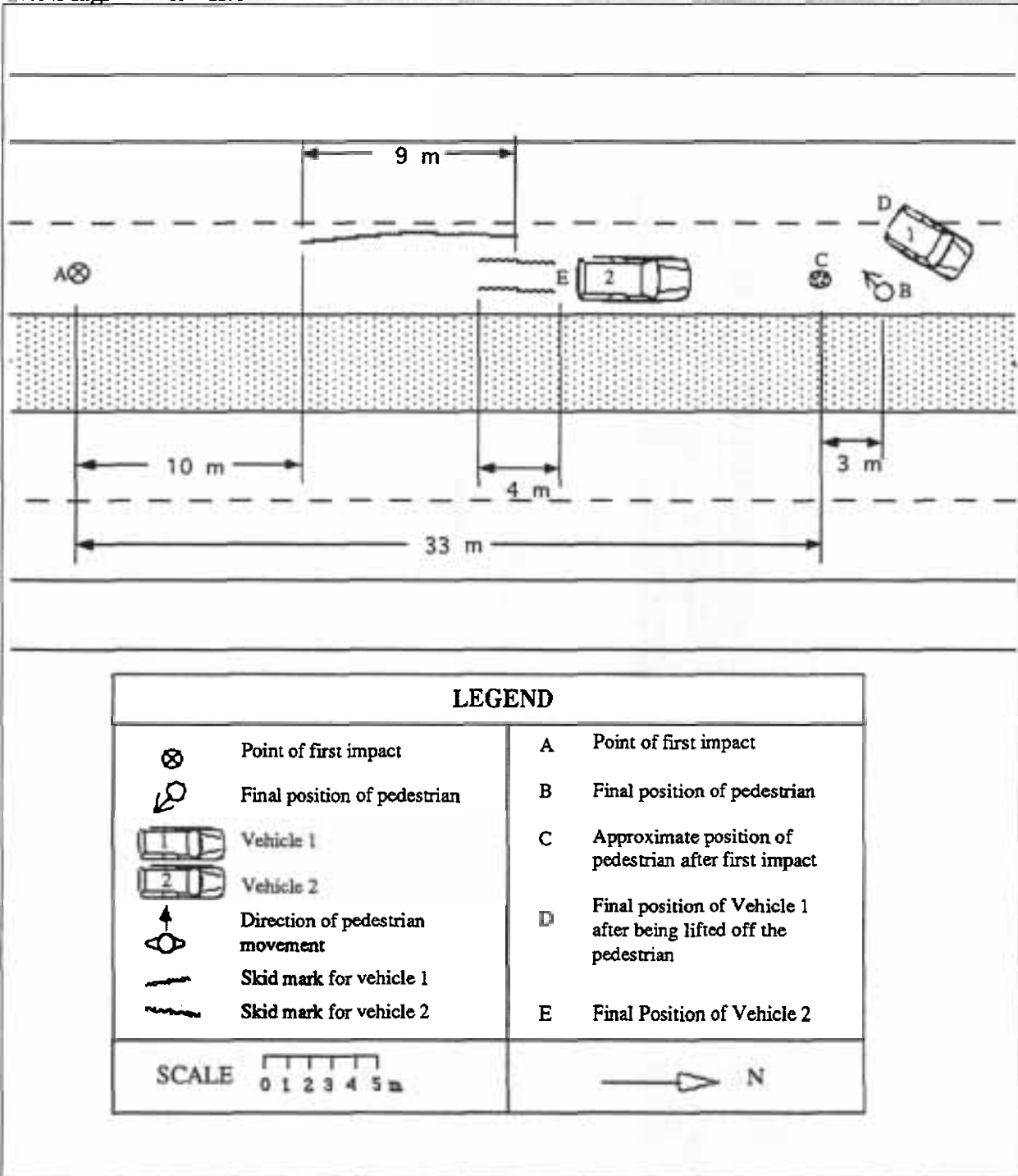

Accident Description

Vehicle 1 was travelling in a northerly direction at 75 km/hr. The pedestrian was standing on the median strip facing in a westerly direction with his head down. The pedestrian then stepped into the path of the vehicle at point A. He was hit on his left side by the front of the right side of the bonnet. The pedestrian was then thrown to the roadway in front of Vehicle 1, which was then run into the back of by a second vehicle and pushed forward onto the pedestrian running over his chest with the front wheel. The pedestrian came to rest at point B under vehicle 1. Vehicle 1 was then lifted off the pedestrian.

Case Details

<i>Case Number</i>	89 - H035	<i>Calculation type</i>	1
<i>Date of Accident</i>	Friday, September	<i>Time</i>	7 pm
<i>Speed Limit</i>	60 km/hr	<i>Number of Pedestrians Involved</i>	1
<i>Travel Speed</i>	50 km/hr	<i>Travel Speed Source</i>	Driver
<i>Impact Speed</i>	50 km/hr	<i>Impact Speed Source</i>	Driver

Pedestrian Details

<i>Fatal</i>	Yes
<i>Age</i>	22
<i>Sex</i>	Male
<i>BAC Pedestrian</i>	0.325 %
<i>Action</i>	Walking
<i>Movement</i>	Crossing the road
<i>Side Impacted</i>	Right side to vehicle

Driver Details

<i>Age</i>	37
<i>Sex</i>	Male
<i>BAC Driver</i>	0 %
<i>Driving Experience</i>	21 years
<i>Licence Type</i>	Full
<i>Driver Action</i>	Braked after impact

Impact Vehicle Details

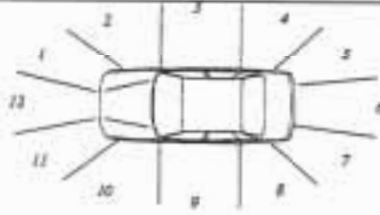
<i>Vehicle Model</i>	1984 Toyota Land Cruiser	
<i>Type</i>	Multi purpose vehicle	
<i>Number Involved</i>	1	
<i>Modifications</i>	Bull bar	
<i>Impact Point</i>	11	

Road Site Details

<i>Traffic Control</i>	None	<i>Road Type</i>	Other main traffic route
<i>Traffic Conditions</i>	Moderate	<i>Road Alignment</i>	Straight
<i>Weather Conditions</i>	Fine, dry road	<i>Natural Lighting</i>	Night
<i>Number of Lanes</i>	1	<i>Street Lighting</i>	Street lights
<i>Road Division</i>	Centre line		

Reduced Travel Speed Analysis

	5 km/hr reduction	10 km/hr reduction	10% reduction	20% reduction
Travel Speed (km/hr)	45	40	45	40
Impact Speed (km/hr)	45	40	45	40

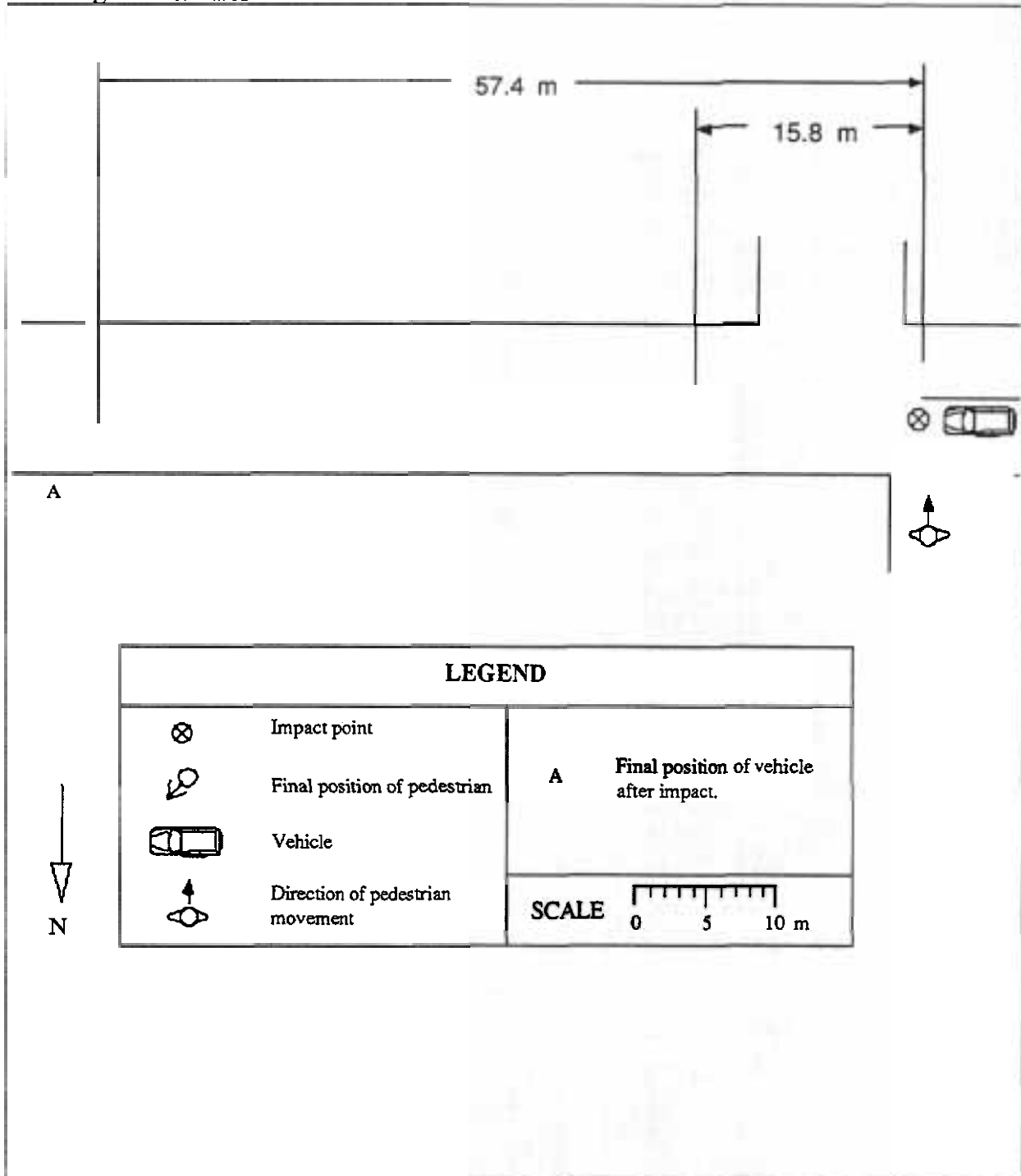

Accident Description

The vehicle was travelling east and collided with the pedestrian who was crossing the road in a southerly direction from the northern side of the road. The driver stated that he was travelling at about 50 km/hr and did not see the pedestrian prior to impact. The driver also stated that he applied the brakes when he realised that his vehicle had struck the pedestrian. No skid marks were left at the scene. The pedestrian was hit on his right hand side by the left hand side of the bull bar of the vehicle.

Case Details

<i>Case Number</i>	89 - H041	<i>Calculation type</i>	3.1
<i>Date of Accident</i>	Monday, December	<i>Time</i>	7 am
<i>Speed Limit</i>	60 km/hr	<i>Number of Pedestrians Involved</i>	1
<i>Travel Speed</i>	50 km/hr	<i>Travel Speed Source</i>	Driver
<i>Impact Speed</i>	43 km/hr	<i>Impact Speed Source</i>	Projection distance

Pedestrian Details

<i>Fatal</i>	Yes
<i>Age</i>	50
<i>Sex</i>	Male
<i>BAC Pedestrian</i>	0 %
<i>Action</i>	Walking
<i>Movement</i>	Crossing the road
<i>Side Impacted</i>	Right side to vehicle

Driver Details

<i>Age</i>	20
<i>Sex</i>	Male
<i>BAC Driver</i>	0 %
<i>Driving Experience</i>	4 years
<i>Licence Type</i>	Full
<i>Driver Action</i>	Braked after impact

Impact Vehicle Details

<i>Vehicle Model</i>	1977 Ford Cortina sedan	<i>Impact Point</i>	11
<i>Type</i>	Car		
<i>Number Involved</i>	1		
<i>Modifications</i>	None		

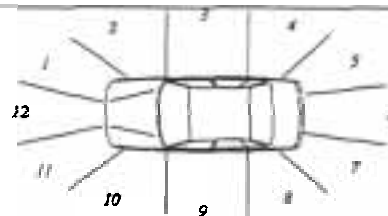

Road Site Details

<i>Traffic Control</i>	None	<i>Road Type</i>	Local street
<i>Traffic Conditions</i>	Light	<i>Road Alignment</i>	Straight
<i>Weather Conditions</i>	Fine, dry road	<i>Natural Lighting</i>	Day
<i>Number of Lanes</i>	1	<i>Street Lighting</i>	Not applicable
<i>Road Division</i>	None		

	5 km/hr reduction	10 km/hr reduction	10% reduction	20% reduction
Travel Speed (km/hr)	45	40	45	40
Impact Speed (km/hr)	27	0	27	0

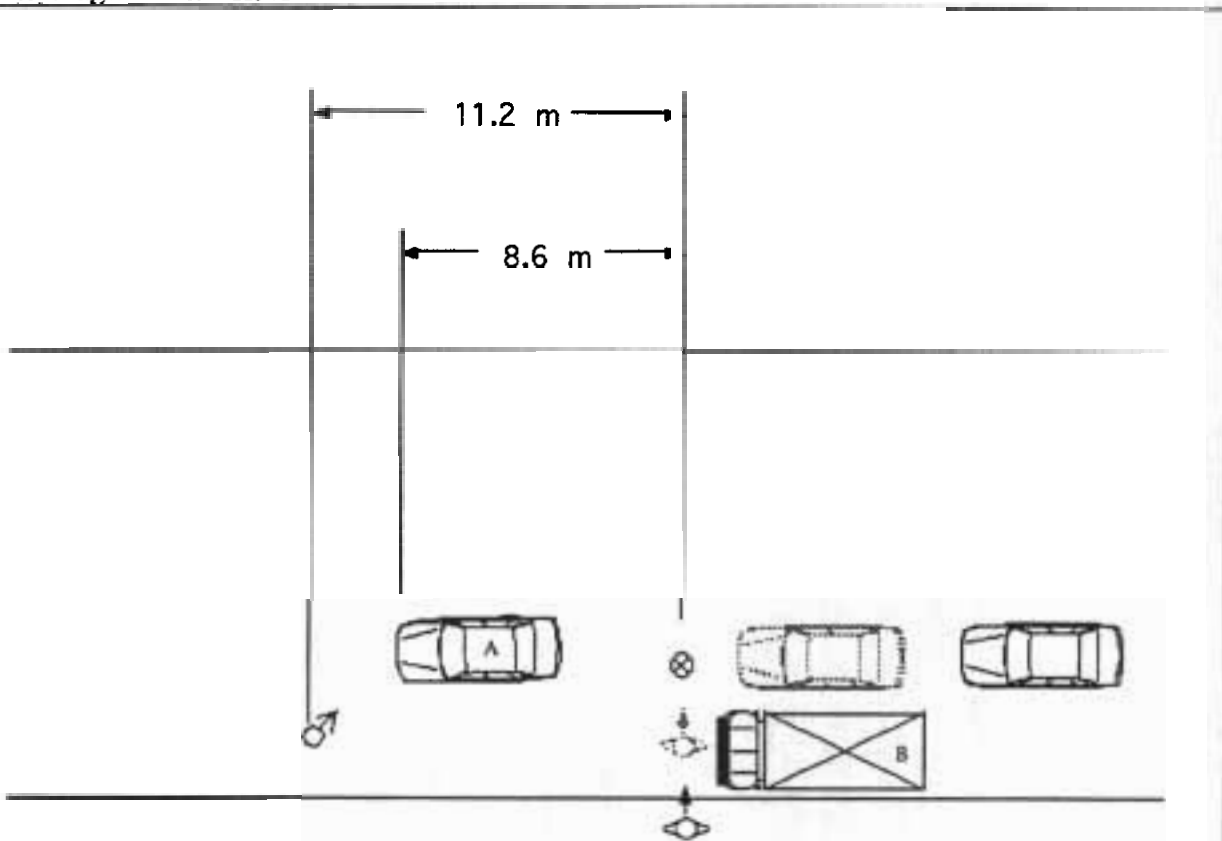

LEGEND					
	Impact point				
	Final position of pedestrian				
	Truck				
	Vehicle				
	Direction of pedestrian movement				
<table border="0"> <tr> <td>A</td> <td>Final car position after impact.</td> </tr> <tr> <td>B</td> <td>Parked truck.</td> </tr> </table>		A	Final car position after impact.	B	Parked truck.
A	Final car position after impact.				
B	Parked truck.				
<p>SCALE </p>					

Accident Description

Vehicle 1 was travelling west when it collided with a pedestrian who was walking in a northerly direction across the road. The pedestrian walked from in front of a parked light truck. The driver stated that he was travelling at about 50 km/hr and saw the pedestrian only seconds before the impact. The driver did not take any evasive action before the impact. The pedestrian was hit by the front left hand corner of the vehicle.

Case Details

<i>Case Number</i>	90 - H002	<i>Calculation type</i>	2.1
<i>Date of Accident</i>	Monday, January	<i>Time</i>	11 am
<i>Speed Limit</i>	60 km/hr	<i>Number of Pedestrians Involved</i>	1
<i>Travel Speed</i>	92 km/hr	<i>Travel Speed Source</i>	Skid marks
<i>Impact Speed</i>	47 km/hr	<i>Impact Speed Source</i>	Skid marks

Pedestrian Details

<i>Fatal</i>	Yes
<i>Age</i>	80
<i>Sex</i>	Female
<i>BAC Pedestrian</i>	Unknown
<i>Action</i>	Walking
<i>Movement</i>	Crossing the road
<i>Side Impacted</i>	Left side to vehicle

Driver Details

<i>Age</i>	Unknown
<i>Sex</i>	
<i>BAC Driver</i>	Unknown
<i>Driving Experience</i>	Unknown
<i>Licence Type</i>	Unknown
<i>Driver Action</i>	Braked before impact

Impact Vehicle Details

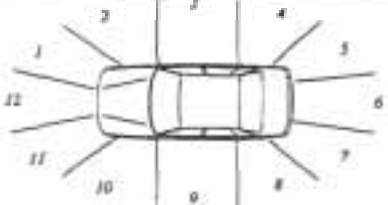
<i>Vehicle Model</i>	Chrysler sedan	<i>Impact Point</i>	12	
<i>Type</i>	Car			
<i>Number Involved</i>	1			
<i>Modifications</i>	None			

Road Site Details

<i>Traffic Control</i>	None	<i>Road Type</i>	Arterial
<i>Traffic Conditions</i>	Moderate	<i>Road Alignment</i>	Straight
<i>Weather Conditions</i>	Fine, dry road	<i>Natural Lighting</i>	Day
<i>Number of Lanes</i>	1	<i>Street Lighting</i>	Not applicable
<i>Road Division</i>	Centre line		

Reduced Travel Speed Analysis

	5 km/hr reduction	10 km/hr reduction	10% reduction	20% reduction
Travel Speed (km/hr)	87	82	83	74
Impact Speed (km/hr)	31	0	0	0

Site Diagram 90 - H002

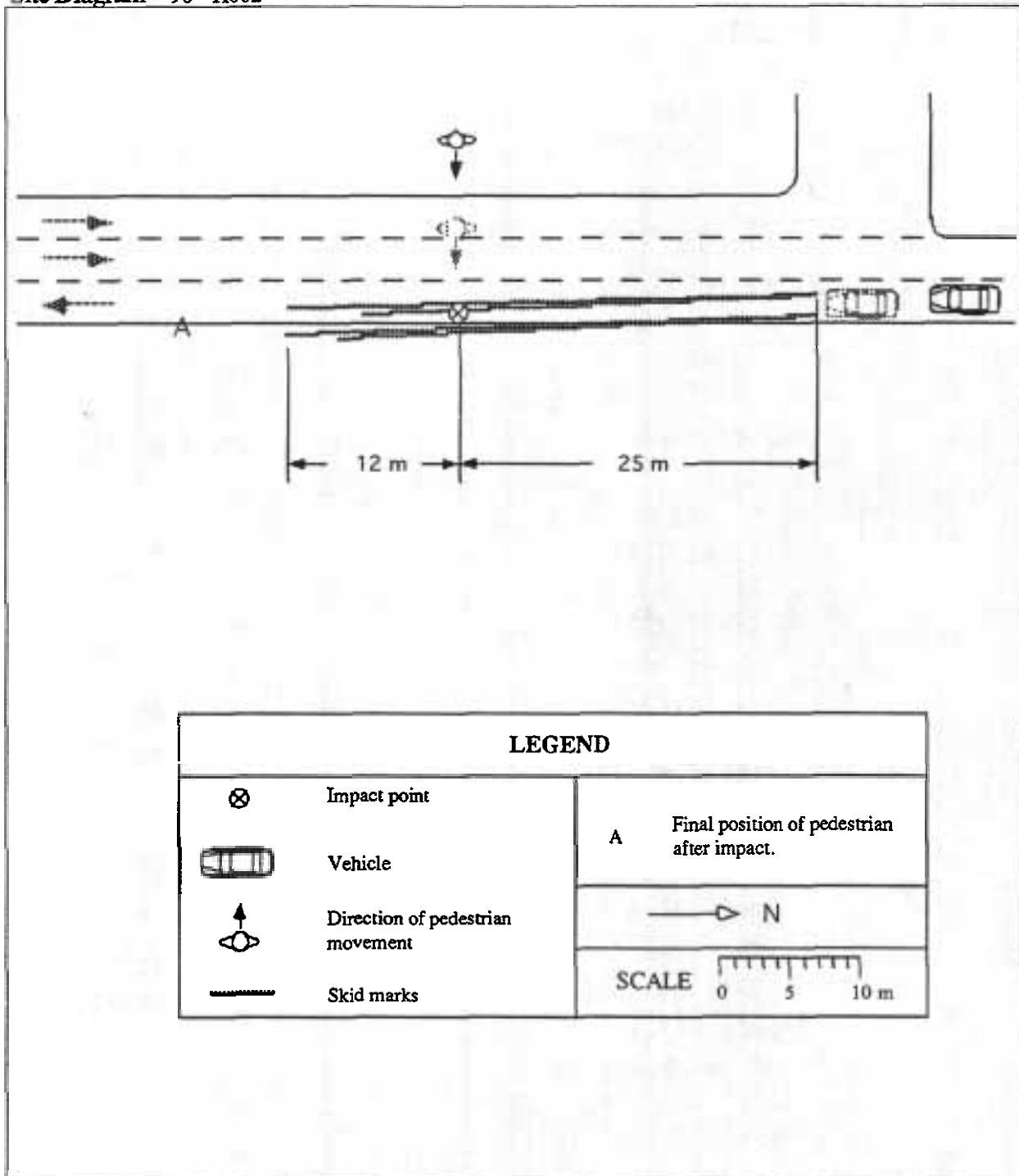

Accident Description

The car was heading south and the pedestrian was crossing the road from west to east when the collision occurred. The pedestrian was hit on her left side by the vehicle and was thrown into the air. The vehicle skidded to a stop in 37 metres. The length of the skid marks from the impact point to the rest position was 12 metres. The pedestrian was thrown 18 metres giving an impact speed estimate of 45 - 50 km/hr.

Case Details

<i>Case Number</i>	90 - H003	<i>Calculation type</i>	1
<i>Date of Accident</i>	Saturday, December	<i>Time</i>	10 am
<i>Speed Limit</i>	60 km/hr	<i>Number of Pedestrians Involved</i>	1
<i>Travel Speed</i>	50 km/hr	<i>Travel Speed Source</i>	Driver
<i>Impact Speed</i>	50 km/hr	<i>Impact Speed Source</i>	Driver

Pedestrian Details

<i>Fatal</i>	Yes
<i>Age</i>	66
<i>Sex</i>	Male
<i>BAC Pedestrian</i>	0 %
<i>Action</i>	Walking
<i>Movement</i>	Crossing the road
<i>Side Impacted</i>	Right side to vehicle

Driver Details

<i>Age</i>	42
<i>Sex</i>	Male
<i>BAC Driver</i>	0 %
<i>Driving Experience</i>	26 years
<i>Licence Type</i>	Full
<i>Driver Action</i>	Braked after impact

Impact Vehicle Details

<i>Vehicle Model</i>	Datsun 180B sedan	<i>Impact Point</i>	12
<i>Type</i>	Car		
<i>Number Involved</i>	1		
<i>Modifications</i>	None		

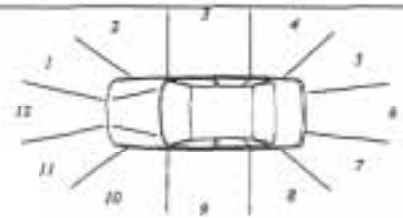

Road Site Details

<i>Traffic Control</i>	Traffic signal at intersection	<i>Road Type</i>	Arterial
<i>Traffic Conditions</i>	Light	<i>Road Alignment</i>	Straight
<i>Weather Conditions</i>	Fine, dry road	<i>Natural Lighting</i>	Day
<i>Number of Lanes</i>	1	<i>Street Lighting</i>	Not applicable
<i>Road Division</i>	Raised median strip		

Reduced Travel Speed Analysis

	5 km/hr reduction	10 km/hr reduction	10% reduction	20% reduction
Travel Speed (km/hr)	45	40	45	40
Impact Speed (km/hr)	45	40	45	40

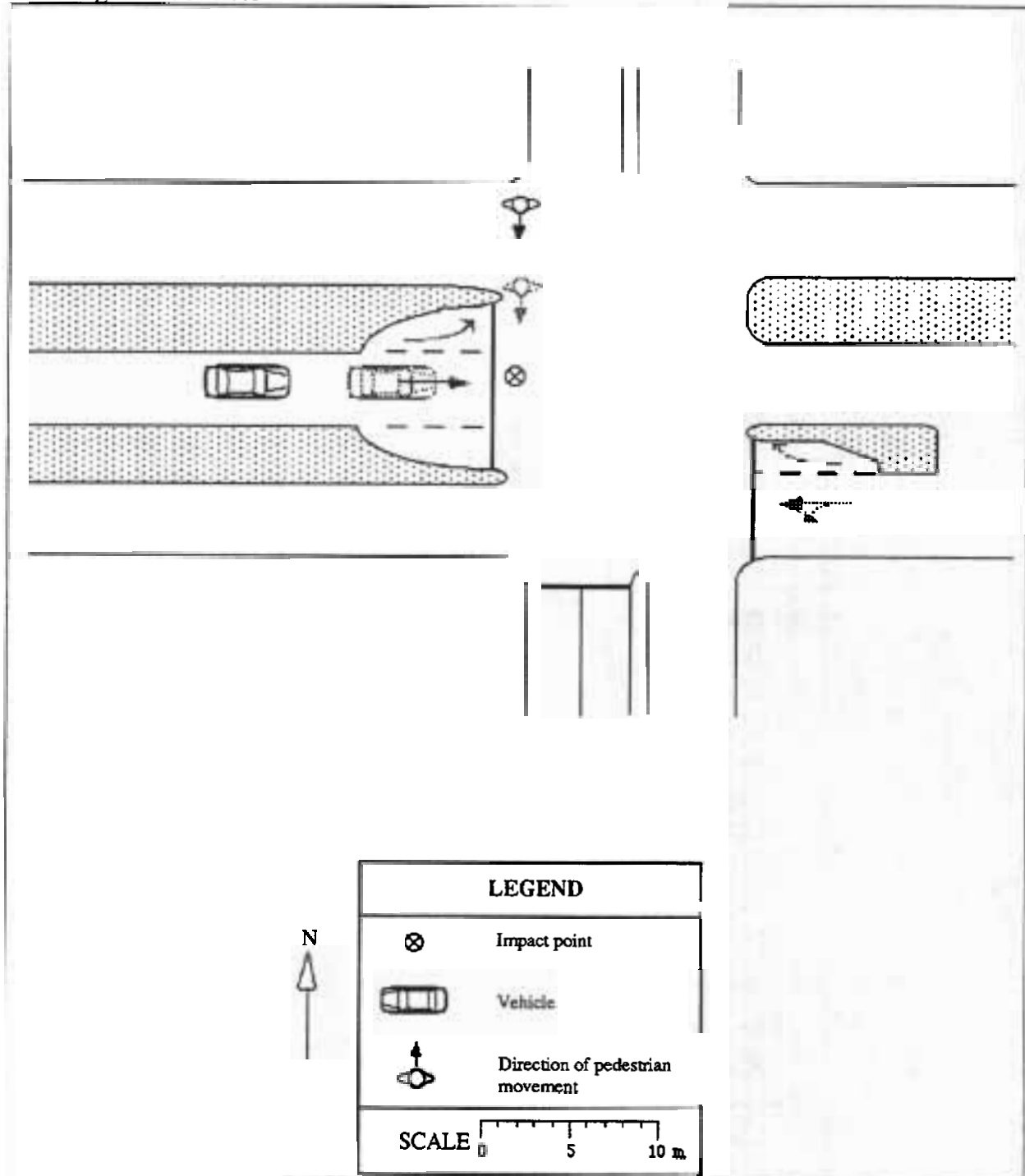

Accident Description

The car was travelling east in the middle lane and collided with a pedestrian crossing the road from north to south. The driver stated that he was travelling about 50 km/hr and did not see the pedestrian prior to the collision. Final position of the pedestrian was not recorded in the files.

Case Details

<i>Case Number</i>	90 - H010	<i>Calculation type</i>	1
<i>Date of Accident</i>	Thursday, April	<i>Time</i>	8 am
<i>Speed Limit</i>	60 km/hr	<i>Number of Pedestrians Involved</i>	1
<i>Travel Speed</i>	55 km/hr	<i>Travel Speed Source</i>	Driver
<i>Impact Speed</i>	55 km/hr	<i>Impact Speed Source</i>	Driver

Pedestrian Details

<i>Fatal</i>	Yes
<i>Age</i>	25
<i>Sex</i>	Male
<i>BAC Pedestrian</i>	Unknown
<i>Action</i>	Running
<i>Movement</i>	Crossing the road
<i>Side Impacted</i>	Right side to vehicle

Driver Details

<i>Age</i>	41
<i>Sex</i>	Male
<i>BAC Driver</i>	Unknown
<i>Driving Experience</i>	25 years
<i>Licence Type</i>	Full
<i>Driver Action</i>	Braked after impact

Impact Vehicle Details

<i>Vehicle Model</i>	1984 Toyota Hiace van	<i>Impact Point</i>	1
<i>Type</i>	Van		
<i>Number Involved</i>	1		
<i>Modifications</i>	None		

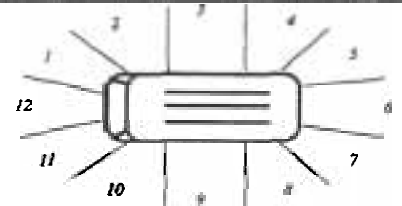

Road Site Details

<i>Traffic Control</i>	None	<i>Road Type</i>	Arterial
<i>Traffic Conditions</i>	Heavy	<i>Road Alignment</i>	Straight
<i>Weather Conditions</i>	Fine, dry road	<i>Natural Lighting</i>	Day
<i>Number of Lanes</i>	1	<i>Street Lighting</i>	Not applicable
<i>Road Division</i>	Centre line		

	5 km/hr reduction	10 km/hr reduction	10% reduction	20% reduction
Travel Speed (km/hr)	50	45	50	44
Impact Speed (km/hr)	50	45	50	44

Site Diagram 90 - H010

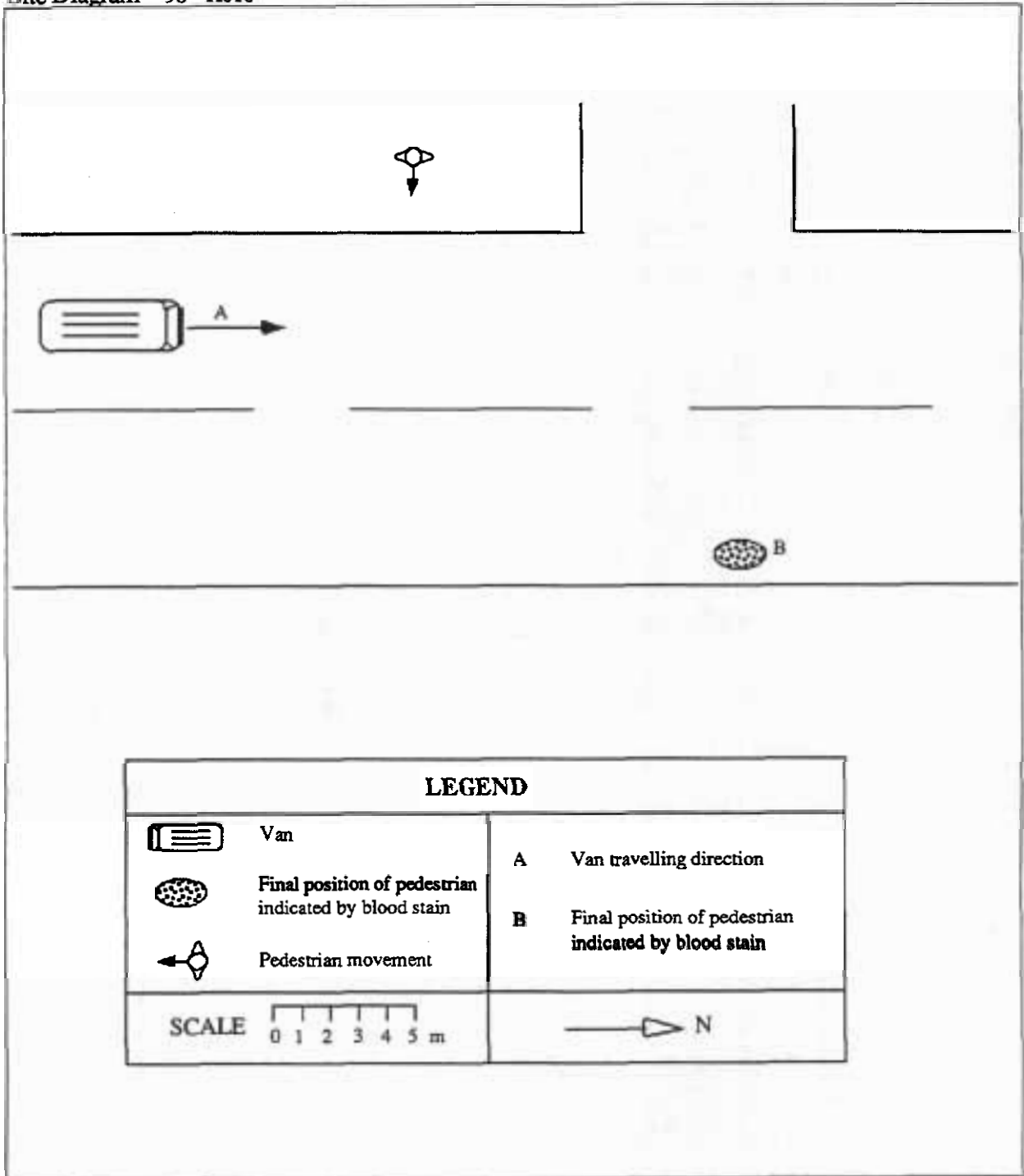

Accident Description

The van was travelling in a northerly direction at 55 km/hr. The pedestrian was running in an easterly direction across the road. The driver of the van did not see the pedestrian before impact. The pedestrian was struck on his right side by the front right side of the van in front of the driver. He was thrown forward and came to rest at point B. Neither the impact point nor the final vehicle position could be located.

Case Details

<i>Case Number</i>	90 - H014	<i>Calculation type</i>	3.1
<i>Date of Accident</i>	Tuesday, May	<i>Time</i>	8 am
<i>Speed Limit</i>	60 km/hr	<i>Number of Pedestrians Involved</i>	1
<i>Travel Speed</i>	60 km/hr	<i>Travel Speed Source</i>	Driver
<i>Impact Speed</i>	58 km/hr	<i>Impact Speed Source</i>	Projection distance

Pedestrian Details

<i>Fatal</i>	Yes
<i>Age</i>	9
<i>Sex</i>	Female
<i>BAC Pedestrian</i>	Unknown
<i>Action</i>	Running
<i>Movement</i>	Crossing the road
<i>Side Impacted</i>	Left side to vehicle

Driver Details

<i>Age</i>	33
<i>Sex</i>	Male
<i>BAC Driver</i>	Unknown
<i>Driving Experience</i>	15 years
<i>Licence Type</i>	Full
<i>Driver Action</i>	Braked after impact

Impact Vehicle Details

<i>Vehicle Model</i>	1968 Morris sedan	<i>Impact Point</i>	12
<i>Type</i>	Car		
<i>Number Involved</i>	1		
<i>Modifications</i>	None		

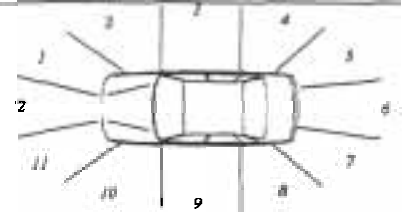

	5 km/hr reduction	10 km/hr reduction	10% reduction	20% reduction
Travel Speed (km/hr)	55	50	54	48
Impact Speed (km/hr)	47	34	45	26

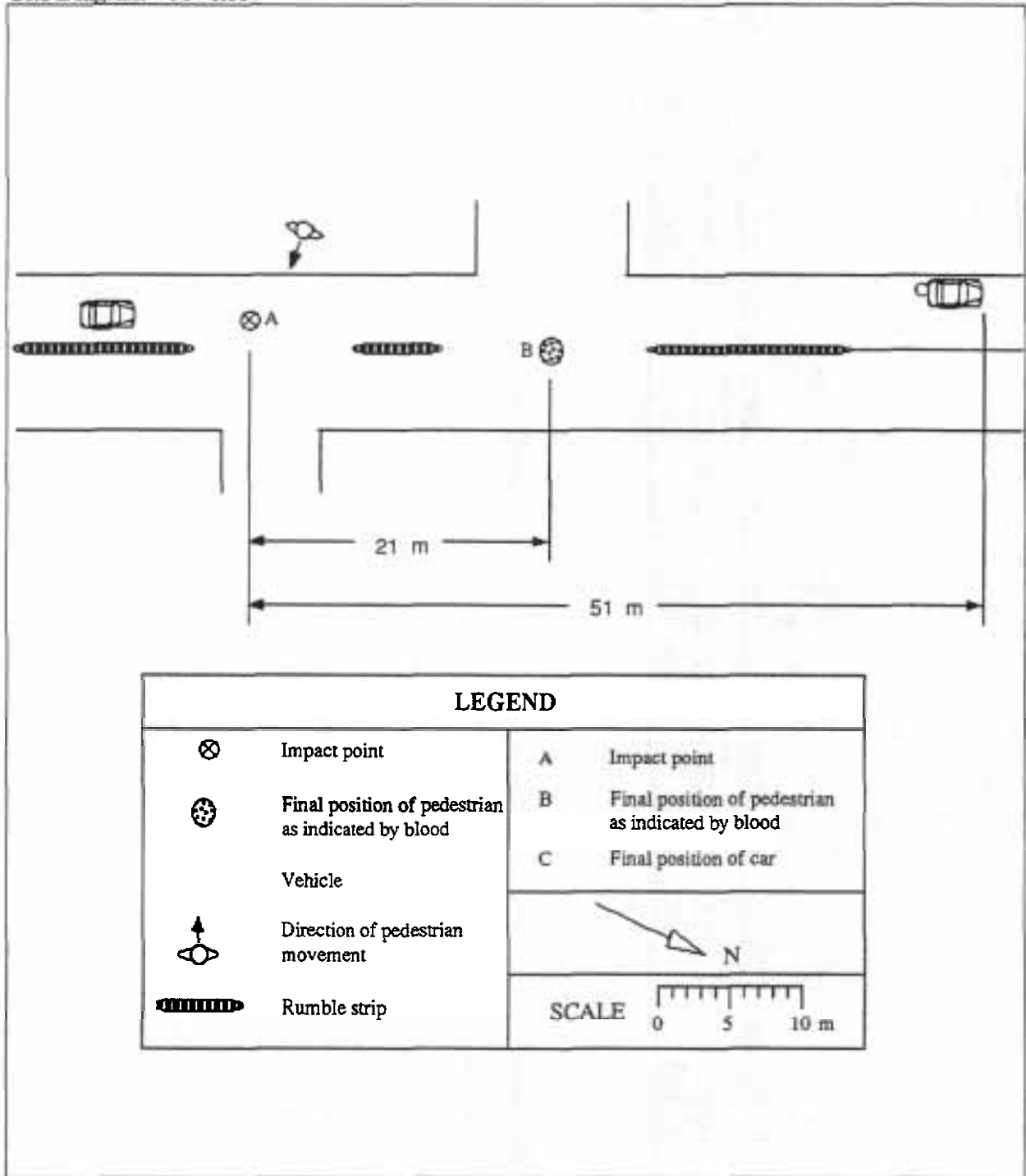

Accident Description

The car was travelling in a north westerly direction at about 60 km/hr when the pedestrian ran from the left hand kerb across the road. The driver saw the pedestrian an instant before impact and braked and tried to swerve. The pedestrian was hit on her right side was thrown up on the bonnet and then fell to the roadway where her feet were run over by the car. She came to rest at point B. The driver pulled her vehicle over and stopped at point C.



<i>Fatal</i>	Yes
<i>Age</i>	27
<i>Sex</i>	Female
<i>BAC Pedestrian</i>	0 %
<i>Action</i>	Standing
<i>Movement</i>	Crossing the road
<i>Side Impacted</i>	Right side to vehicle

<i>Age</i>	18
<i>Sex</i>	Male
<i>BAC Driver</i>	0 %
<i>Driving Experience</i>	2 years
<i>Licence Type</i>	Full
<i>Driver Action</i>	No evasive action



Road Site Details

<i>Traffic Control</i>	None	<i>Road Type</i>	Arterial
<i>Traffic Conditions</i>	Heavy	<i>Road Alignment</i>	Straight
<i>Weather Conditions</i>	Fine, dry road	<i>Natural Lighting</i>	Day
<i>Number of Lanes</i>	1	<i>Street Lighting</i>	None
<i>Road Division</i>	None		

Reduced Travel Speed Analysis

	5 km/hr reduction	10 km/hr reduction	10% reduction	20% reduction
Travel Speed (km/hr)	57	52	56	50
Impact Speed (km/hr)	57	52	56	50

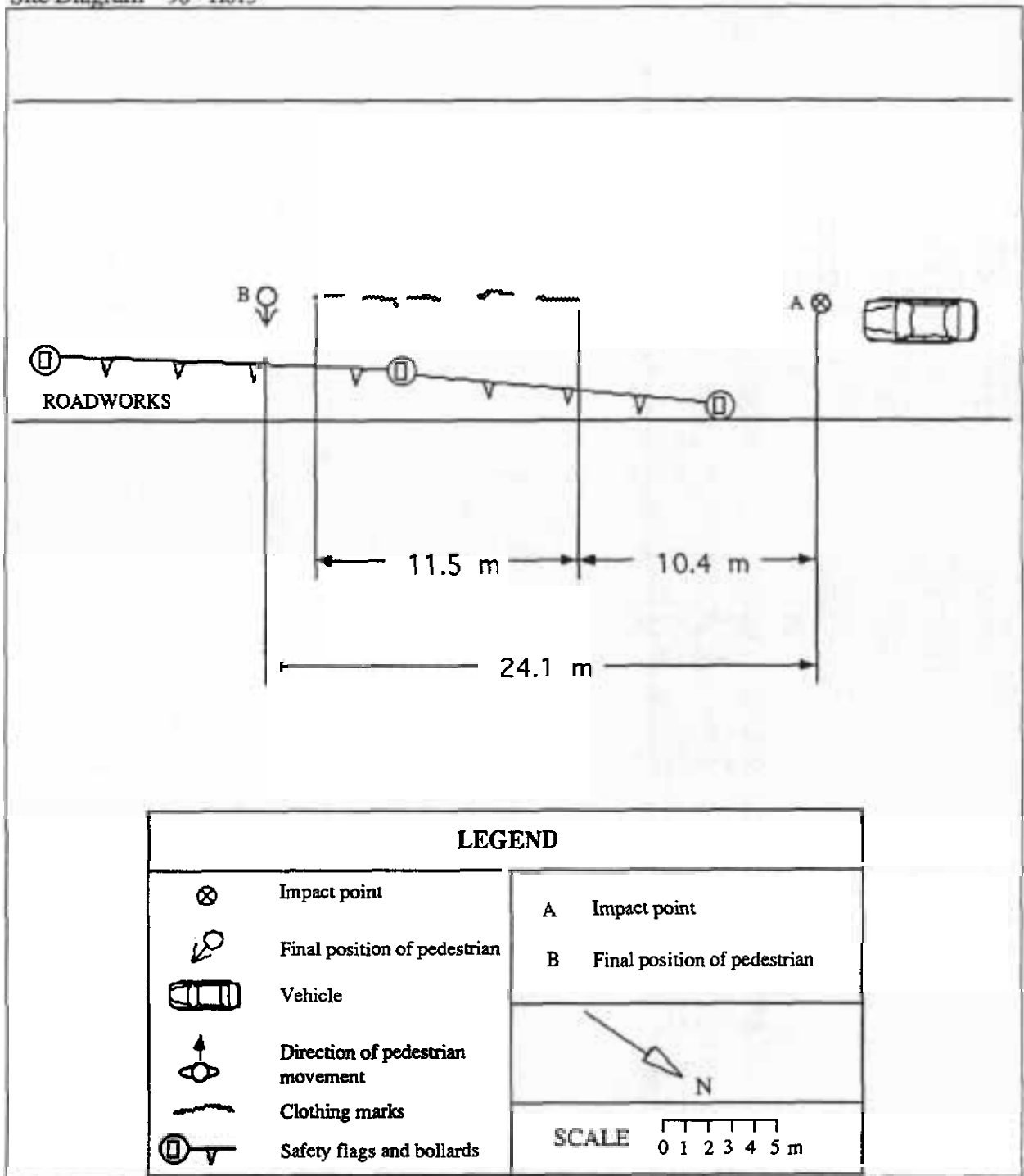

Accident Description

The car was travelling in a south easterly direction at about 62 km/hr. Three pedestrians were crossing the road in a north easterly direction and stopped near the centre of the road for traffic to pass. The pedestrians were holding hands when the car struck one of them. The driver of the vehicle did not see the pedestrians before the impact. The pedestrian was struck on her left hand side by right hand side of the front of the car above the headlights. She was thrown onto the bonnet, impacted her head on the plenum, went over the roof, onto the boot and then fell to the road. She came to rest at point B. The driver continued and parked in a carpark before returning to the scene.

Case Details

<i>Case Number</i>	90 - H016	<i>Calculation type</i>	2.2
<i>Date of Accident</i>	Saturday, May	<i>Time</i>	7 pm
<i>Speed Limit</i>	80 km/hr	<i>Number of Pedestrians Involved</i>	1
<i>Travel Speed</i>	80 km/hr	<i>Travel Speed Source</i>	Driver
<i>Impact Speed</i>	51 km/hr	<i>Impact Speed Source</i>	Skid marks

Pedestrian Details

<i>Fatal</i>	Yes
<i>Age</i>	26
<i>Sex</i>	Male
<i>BAC Pedestrian</i>	Unknown
<i>Action</i>	Running
<i>Movement</i>	Crossing the road
<i>Side Impacted</i>	Right side to vehicle

Driver Details

<i>Age</i>	22
<i>Sex</i>	Male
<i>BAC Driver</i>	0 %
<i>Driving Experience</i>	4 years
<i>Licence Type</i>	Full
<i>Driver Action</i>	Braked before impact

Impact Vehicle Details

<i>Vehicle Model</i>	1978 Holden Commodore sedan	<i>Impact Point</i>	1
<i>Type</i>			
<i>Number Involved</i>	1		
<i>Modifications</i>	None		

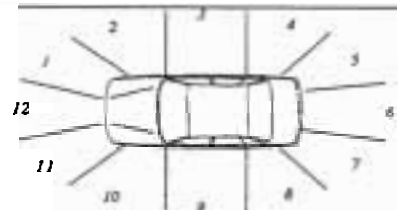

Road Site Details

--	--	--	--	--

	5 km/hr reduction	10 km/hr reduction	10% reduction	20% reduction
Travel Speed (km/hr)	75	70	72	64
Impact Speed (km/hr)	39	21	29	0

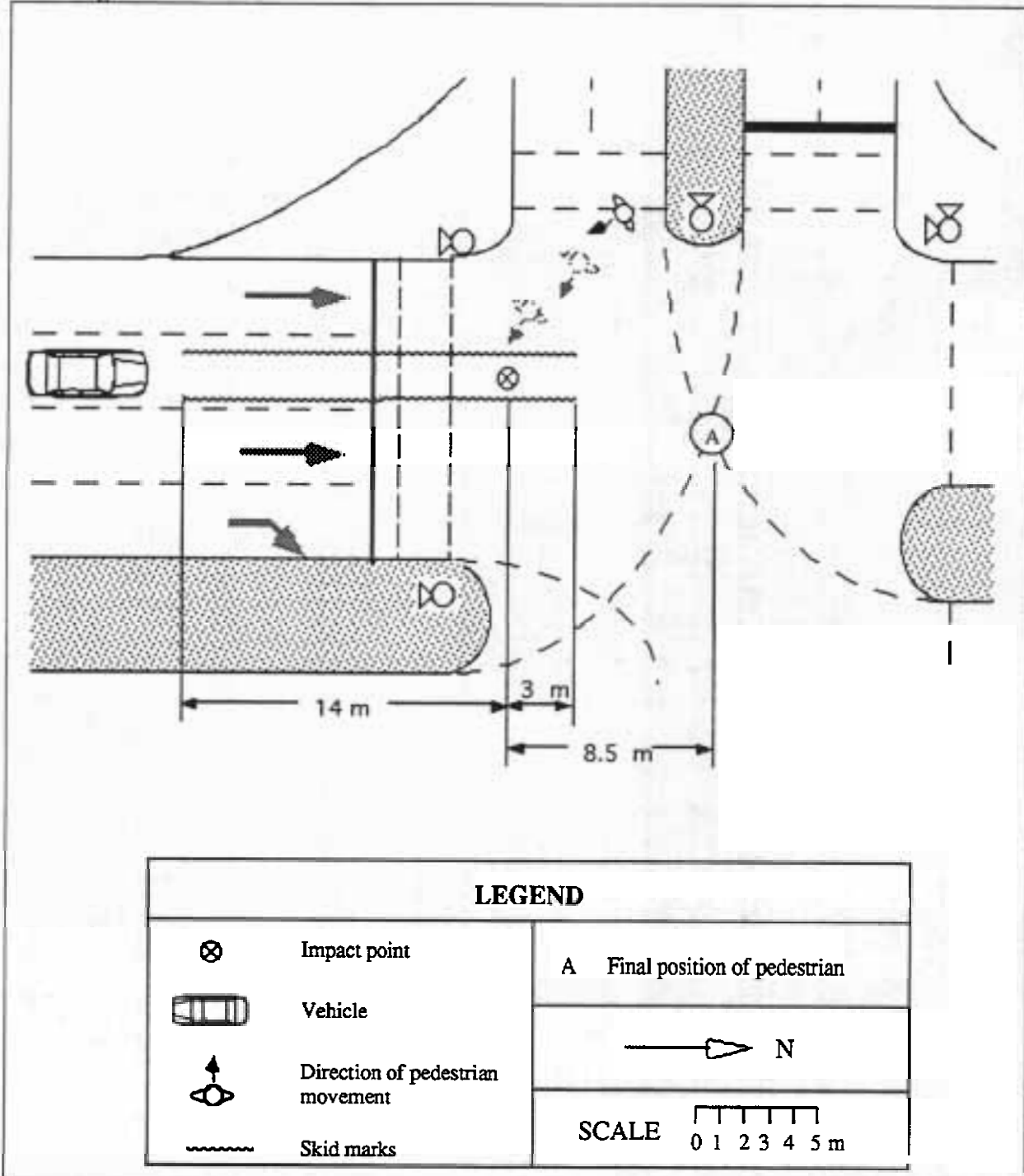

Accident Description

The car was travelling north heading towards a signalised intersection. The pedestrian was attempting to cross from west to east at the southern pedestrian crossing without waiting for the lights to change in his favour. The driver braked and then, while still skidding, struck the pedestrian. The driver stated that he was travelling at about 80 km/hr. The pedestrian was hit by the right side of the vehicle.

Case Details

<i>Case Number</i>	90 - H024	<i>Calculation type</i>	1
<i>Date of Accident</i>	Friday, August	<i>Time</i>	5 pm
<i>Speed Limit</i>	60 km/hr	<i>Number of Pedestrians Involved</i>	1
<i>Travel Speed</i>	40 km/hr	<i>Travel Speed Source</i>	Driver
<i>Impact Speed</i>	40 km/hr	<i>Impact Speed Source</i>	Driver

<i>Fatal</i>	Yes	<i>Age</i>	22
<i>Age</i>	57	<i>Sex</i>	Male
<i>Sex</i>	Male	<i>BAC Driver</i>	0 %
<i>BAC Pedestrian</i>	0.342 %	<i>Driving Experience</i>	6 years
<i>Action</i>	Lying on road	<i>Licence Type</i>	Full
<i>Movement</i>	Other	<i>Driver Action</i>	No evasive action
<i>Side Impacted</i>	Left side to vehicle		

Impact Vehicle Details

<i>Vehicle Model</i>	Mazda 929L sedan	<i>Impact Point</i>	12
<i>Type</i>	Car		

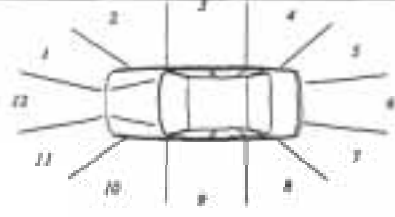

Road Site Details

<i>Traffic Control</i>	Traffic signal at intersection	<i>Road Type</i>	Arterial
<i>Traffic Conditions</i>	Heavy	<i>Road Alignment</i>	Straight
<i>Weather Conditions</i>	Raining	<i>Natural Lighting</i>	Dusk
<i>Number of Lanes</i>	4	<i>Street Lighting</i>	Street lights
<i>Road Division</i>	Raised median strip		

Reduced Travel Speed Analysis

	5 km/hr reduction	10 km/hr reduction	10% reduction	20% reduction
Travel Speed (km/hr)	35	30	36	32
Impact Speed (km/hr)	35	30	36	32

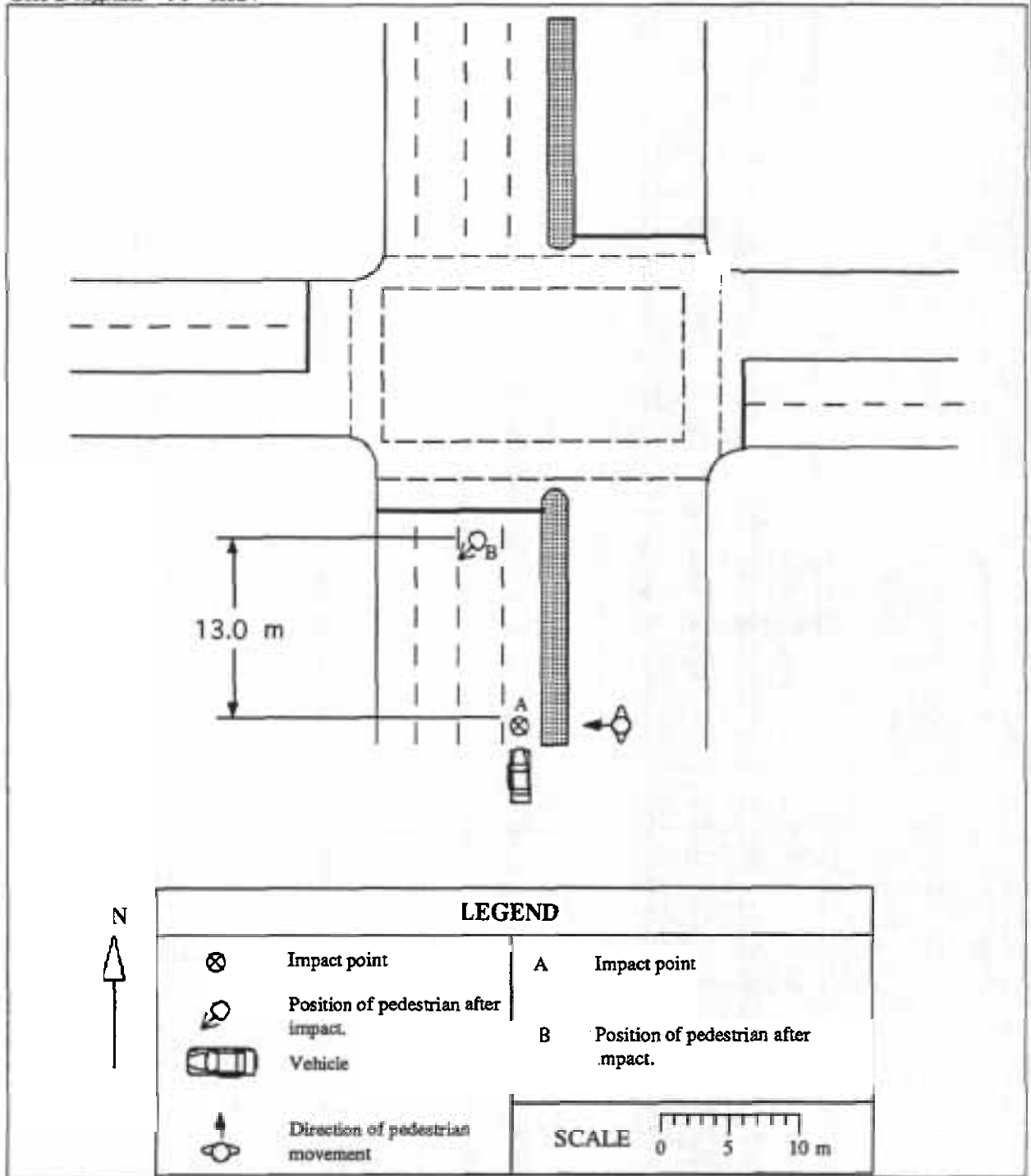

Accident Description

The pedestrian was walking in a westerly direction across an arterial road. From a witness statement the pedestrian appeared slow and disoriented. The pedestrian fell onto the roadway and lay on his right hand side for approximately 10 seconds before a bank of traffic travelling north approached and a vehicle in the eastern most lane collided with him. The driver stated that he saw the pedestrian immediately in front of his car and did not have time to take any evasive action or time to brake before the collision. At the time of the collision, the roadway was wet and the visibility was poor.

Case Details

<i>Case Number</i>	90 - H028	<i>Calculation type</i>	1
<i>Date of Accident</i>	Saturday, August	<i>Time</i>	6 pm
<i>Speed Limit</i>	60 km/hr	<i>Number of Pedestrians Involved</i>	1
<i>Travel Speed</i>	76 km/hr	<i>Travel Speed Source</i>	Projection distance
<i>Impact Speed</i>	76 km/hr	<i>Impact Speed Source</i>	Projection distance

Pedestrian Details

<i>Fatal</i>	Yes
<i>Age</i>	29
<i>Sex</i>	Male
<i>BAC Pedestrian</i>	0 %
<i>Action</i>	Other
<i>Movement</i>	Crossing the road
<i>Side Impacted</i>	Right side to vehicle

Driver Details

<i>Age</i>	37
<i>Sex</i>	Male
<i>BAC Driver</i>	0 %
<i>Driving Experience</i>	20 years
<i>Licence Type</i>	Full
<i>Driver Action</i>	No evasive action

Impact Vehicle Details

<i>Vehicle Model</i>	1973 Ford Cortina sedan	<i>Impact Point</i>	1
<i>Type</i>	Car		
<i>Number Involved</i>	1		
<i>Modifications</i>	None		

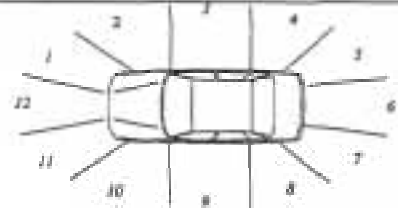

Road Site Details

<i>Traffic Control</i>	None	<i>Road Type</i>	Arterial
<i>Traffic Conditions</i>	Moderate	<i>Road Alignment</i>	Straight
<i>Weather Conditions</i>	Fine, dry road	<i>Natural Lighting</i>	Dusk
<i>Number of Lanes</i>	1	<i>Street Lighting</i>	Street lights
<i>Road Division</i>	Centre line		

Reduced Travel Speed Analysis

	5 km/hr reduction	10 km/hr reduction	10% reduction	20% reduction
Travel Speed (km/hr)	71	66	68	60
Impact Speed (km/hr)	71	66	68	60

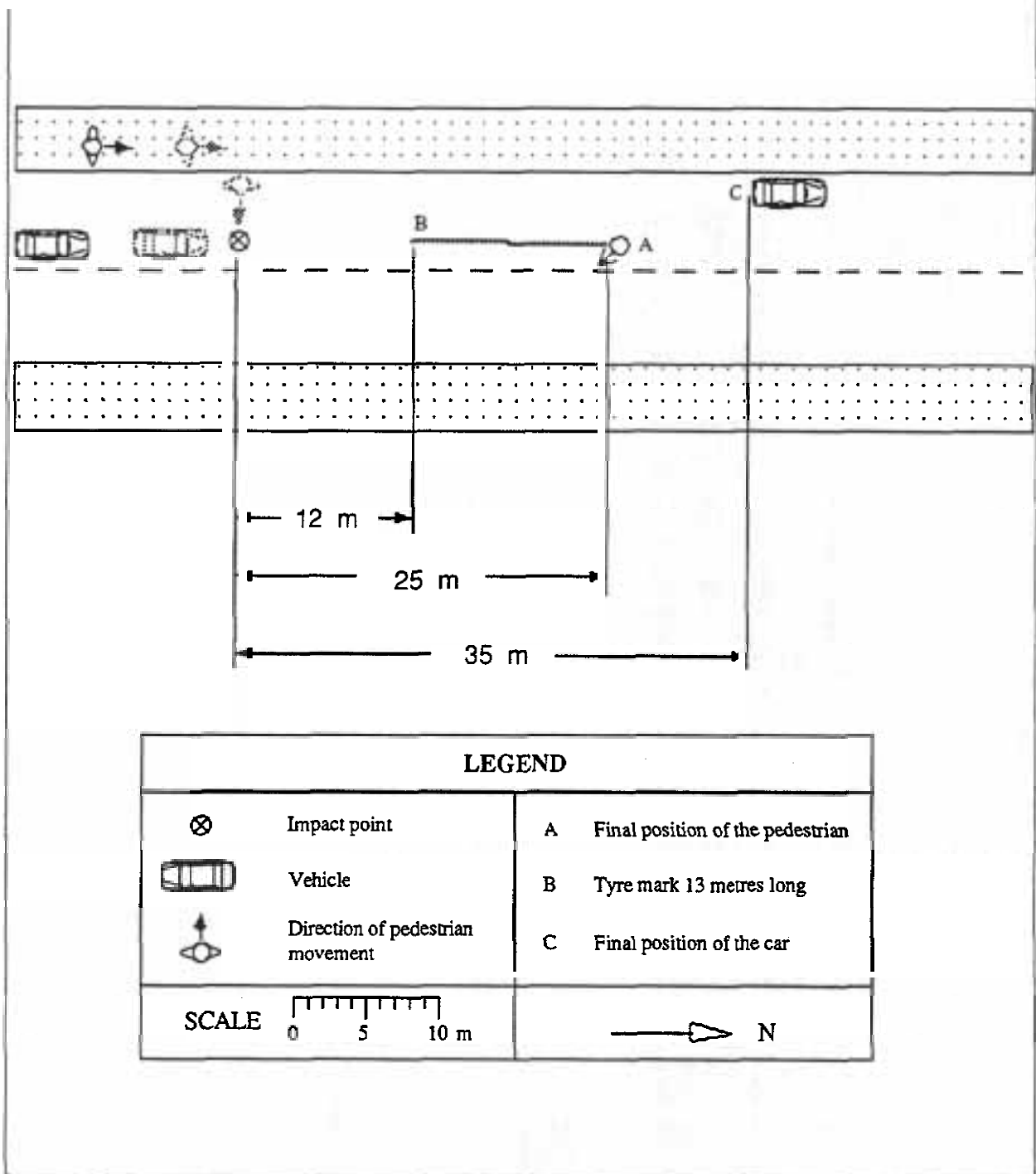

Accident Description

The car was travelling north at about 76 km/hr. The pedestrian was walking with the aid of crutches in a northerly direction on the footpath before turning to cross the road from west to east. From a witness statement, the pedestrian was about half way across the north bound lane when he dropped something on the road way and at the time of collision he was bending down. A witness said that the driver did not appear to brake or slow down before the collision. The pedestrian was hit by the front right hand side of the vehicle.

Case Details

<i>Case Number</i>	90 - H030	<i>Calculation type</i>	1
<i>Date of Accident</i>	Tuesday, September	<i>Time</i>	3 pm
<i>Speed Limit</i>	60 km/hr	<i>Number of Pedestrians Involved</i>	1
<i>Travel Speed</i>	55 km/hr	<i>Travel Speed Source</i>	Driver
<i>Impact Speed</i>	55 km/hr	<i>Impact Speed Source</i>	Driver

Pedestrian Details

<i>Fatal</i>	Yes
<i>Age</i>	52
<i>Sex</i>	Male
<i>BAC Pedestrian</i>	0 %
<i>Action</i>	Walking
<i>Movement</i>	Crossing the road
<i>Side Impacted</i>	Right side to vehicle

Driver Details

<i>Age</i>	28
<i>Sex</i>	Male
<i>BAC Driver</i>	0 %
<i>Driving Experience</i>	12 years
<i>Licence Type</i>	Full
<i>Driver Action</i>	Braked after impact

Impact Vehicle Details

<i>Vehicle Model</i>	1974 Ford Cortina sedan	<i>Impact Point</i>	12
<i>Type</i>	Car		
<i>Number Involved</i>	1		
<i>Modifications</i>	None		

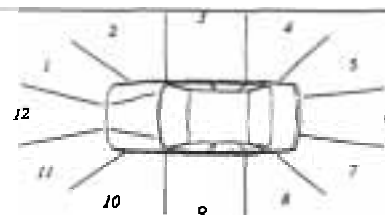

Road Site Details

<i>Traffic Control</i>	None	<i>Road Type</i>	Arterial
<i>Traffic Conditions</i>	Heavy	<i>Road Alignment</i>	Straight
<i>Weather Conditions</i>	Raining	<i>Natural Lighting</i>	Day
<i>Number of Lanes</i>	2	<i>Street Lighting</i>	Not applicable
<i>Road Division</i>	Painted median strip		

	5 km/hr reduction	10 km/hr reduction	10% reduction	20% reduction
Travel Speed (km/hr)	50	45	50	44
Impact Speed (km/hr)	50	45	50	44

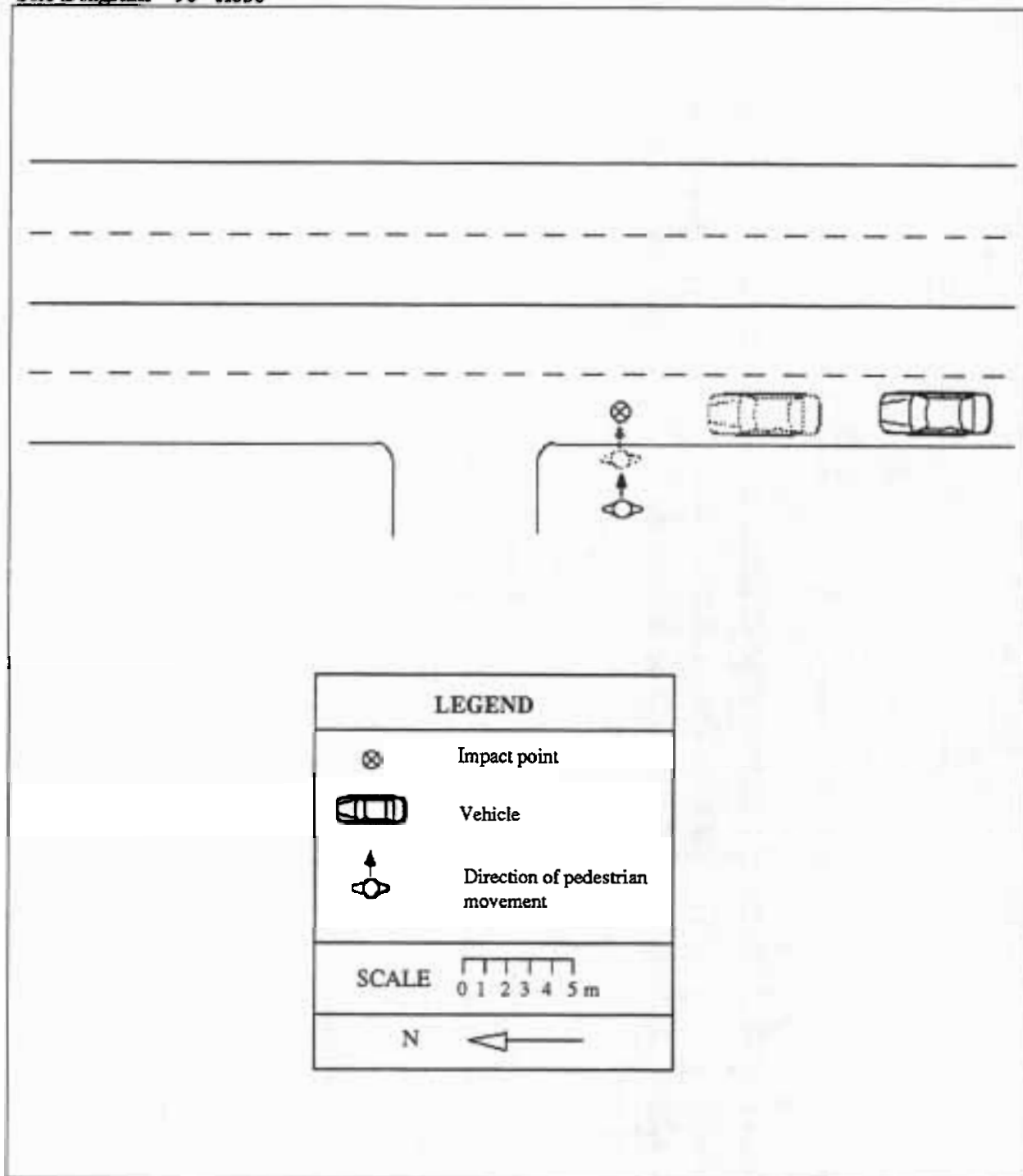

Accident Description

The car was travelling north in the left lane when it collided with a pedestrian crossing the road from west to east. The driver stated that he was travelling at about 55 km/hr and did not see the pedestrian until a passenger in his vehicle called out to him a split second before impact. No evasive action was taken by driver before impact.

Case Details

<i>Case Number</i>	90 - H037	<i>Calculation type</i>	1
<i>Date of Accident</i>	Saturday, December	<i>Time</i>	2 am
<i>Speed Limit</i>	60 km/hr	<i>Number of Pedestrians Involved</i>	1
<i>Travel Speed</i>	60 km/hr	<i>Travel Speed Source</i>	Driver
<i>Impact Speed</i>	60 km/hr	<i>Impact Speed Source</i>	Driver

Pedestrian Details

<i>Fatal</i>	Yes
<i>Age</i>	35
<i>Sex</i>	Male
<i>BAC Pedestrian</i>	0.189 %
<i>Action</i>	Walking
<i>Movement</i>	Crossing the road
<i>Side Impacted</i>	Unknown

Driver Details

<i>Age</i>	25
<i>Sex</i>	Male
<i>BAC Driver</i>	Unknown
<i>Driving Experience</i>	Unknown years
<i>Licence Type</i>	Full
<i>Driver Action</i>	Braked before impact

Impact Vehicle Details

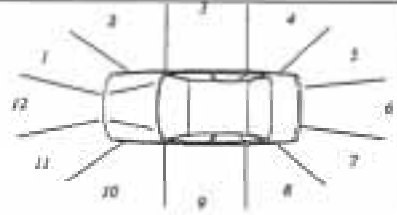
<i>Vehicle Model</i>	1974 Toyota Corolla sedan	
<i>Type</i>	Car	
<i>Impact Point</i>	12	
<i>Number Involved</i>	1	
<i>Modifications</i>	None	

Road Site Details

<i>Traffic Control</i>	None	<i>Road Type</i>	Arterial
<i>Traffic Conditions</i>	Light	<i>Road Alignment</i>	Straight
<i>Weather Conditions</i>	Fine, dry road	<i>Natural Lighting</i>	Night
<i>Number of Lanes</i>	2	<i>Street Lighting</i>	Street lights
<i>Road Division</i>	Painted median strip		

Reduced Travel Speed Analysis

	5 km/hr reduction	10 km/hr reduction	10% reduction	20% reduction
Travel Speed (km/hr)	55	50	54	48
Impact Speed (km/hr)	55	50	54	48

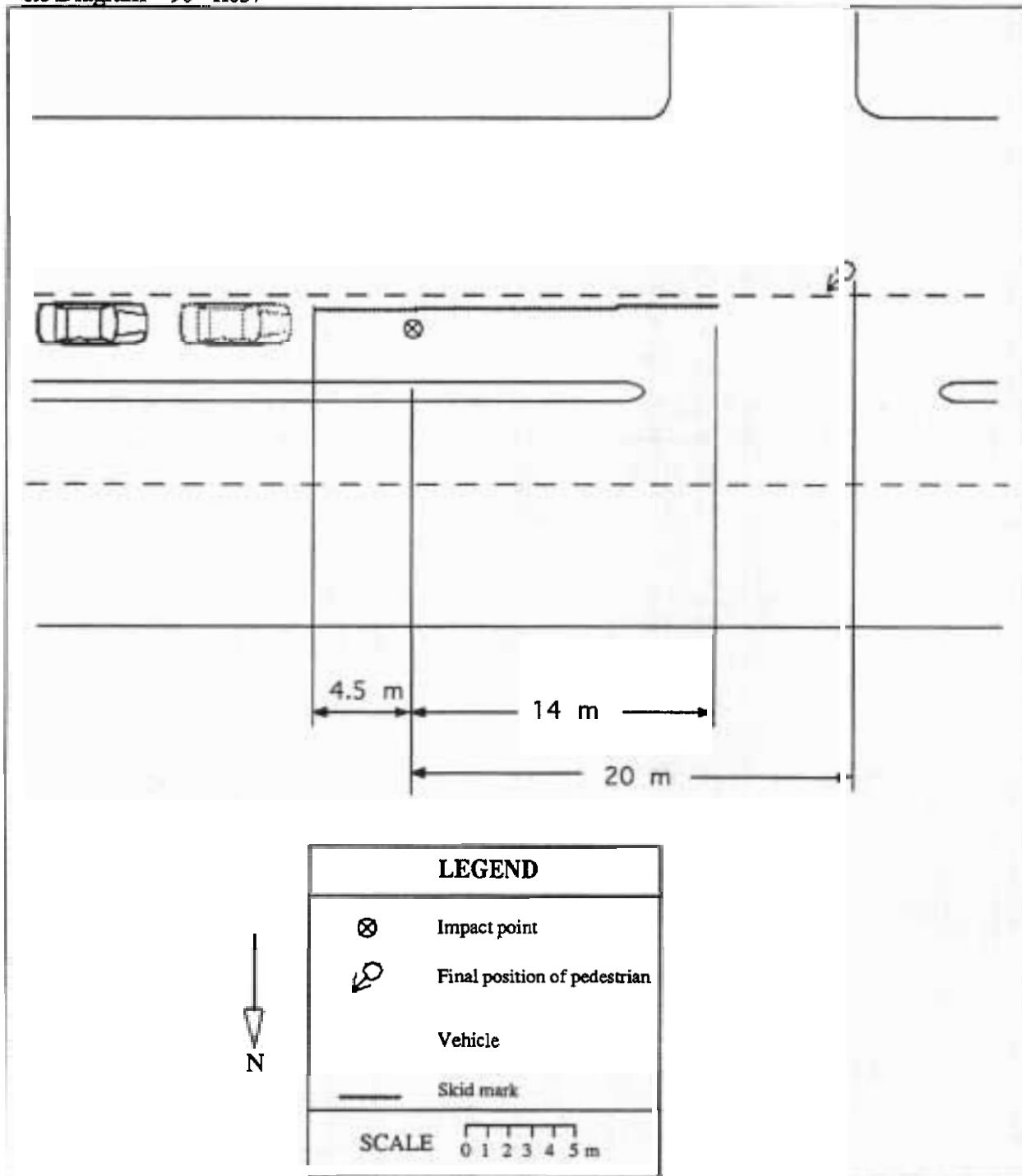

Accident Description

The car was travelling west in the right lane and collided with a pedestrian who was crossing the road (orientation unknown). The driver stated that he was travelling at about 60 km/hr and that he did not see the pedestrian prior to the impact and therefore took no evasive action. A witness also stated that he did not see the brake lights of the vehicle come on. The point of impact from the police files was located along the skid mark, indicating that the driver may have braked before the impact point. The pedestrian was hit by the centre right of the front of the vehicle.

Case Details

<i>Case Number</i>	91 - H012	<i>Calculation type</i>	3.1
<i>Date of Accident</i>	Saturday, March	<i>Time</i>	7 pm
<i>Speed Limit</i>	60 km/hr	<i>Number of Pedestrians Involved</i>	1
<i>Travel Speed</i>	40 km/hr	<i>Travel Speed Source</i>	Driver
<i>Impact Speed</i>	26 km/hr	<i>Impact Speed Source</i>	Projection distance

Pedestrian Details

<i>Fatal</i>	Yes
<i>Age</i>	79
<i>Sex</i>	Female
<i>BAC Pedestrian</i>	0 %
<i>Action</i>	Walking
<i>Movement</i>	Crossing the road
<i>Side Impacted</i>	Right side to vehicle

Driver Details

<i>Age</i>	17
<i>Sex</i>	Male
<i>BAC Driver</i>	0.016 %
<i>Driving Experience</i>	8 months
<i>Licence Type</i>	Probationary
<i>Driver Action</i>	Braked before impact

Impact Vehicle Details

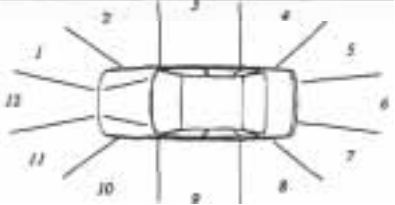
<i>Vehicle Model</i>	1978 Mazda 323 sedan	<i>Impact Point</i>	1	
<i>Type</i>	Car			
<i>Number Involved</i>	1			
<i>Modifications</i>	None			





Road Site Details

<i>Traffic Control</i>	None	<i>Road Type</i>	Arterial
<i>Traffic Conditions</i>	Moderate	<i>Road Alignment</i>	Straight
<i>Weather Conditions</i>	Fine, dry road	<i>Natural Lighting</i>	Day
<i>Number of Lanes</i>	2	<i>Street Lighting</i>	None
<i>Road Division</i>	Centre line		

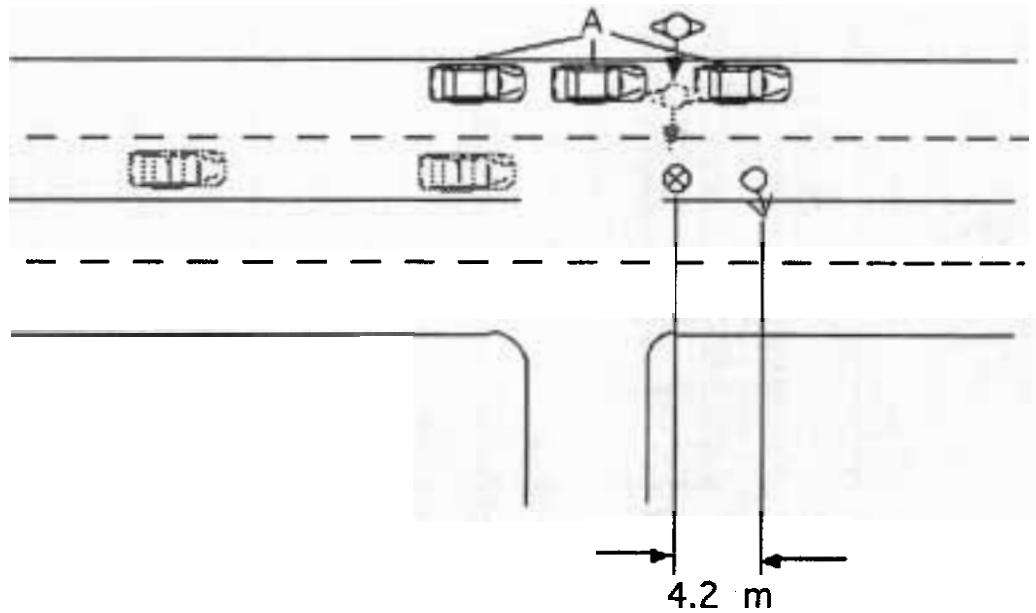
Reduced Travel Speed Analysis

	5 km/hr	10 km/hr	10%	20%
<i>Travel Speed (km/hr)</i>	35	30	36	32
<i>Impact Speed (km/hr)</i>	0	0	0	0

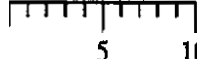

LEGEND	
	Impact point
	Final position of pedestrian
	Vehicle
	Direction of pedestrian movement
A Parked vehicles.	
SCALE 	

Accident Description

The car was travelling west at about 40 km/hr in the left hand lane of a two lane road for west bound traffic. The pedestrian walked between parked cars on the southern side of the road and was walking in a northerly direction when he was struck by the vehicle. The driver stated that he had insufficient time to react when the pedestrian appeared in front of him. The pedestrian was hit by the front right hand corner of the vehicle.

Case Details

<i>Case Number</i>	91 - H016	<i>Calculation type</i>	2.1
<i>Date of Accident</i>	Friday, April	<i>Time</i>	6 pm
<i>Speed Limit</i>	60 km/hr	<i>Number of Pedestrians Involved</i>	1
<i>Travel Speed</i>	57 km/hr	<i>Travel Speed Source</i>	Skid marks
<i>Impact Speed</i>	46 km/hr	<i>Impact Speed Source</i>	Skid marks

Pedestrian Details

<i>Fatal</i>	Yes
<i>Age</i>	27
<i>Sex</i>	Male
<i>BAC Pedestrian</i>	Unknown
<i>Action</i>	Walking
<i>Movement</i>	Crossing the road
<i>Side Impacted</i>	Left side to vehicle

Driver Details

<i>Age</i>	Unknown
<i>Sex</i>	
<i>BAC Driver</i>	Unknown
<i>Driving Experience</i>	Unknown
<i>Licence Type</i>	Unknown
<i>Driver Action</i>	Braked before impact

Impact Vehicle Details

<i>Vehicle Model</i>	1973 Alfa Romeo sedan	<i>Impact Point</i>	12
<i>Type</i>	Car		
<i>Number Involved</i>	1		
<i>Modifications</i>	None		

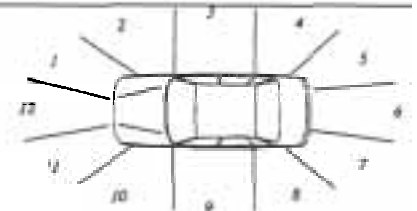

Road Site Details

<i>Traffic Control</i>	Traffic signal at intersection	<i>Road Type</i>	Arterial
<i>Traffic Conditions</i>	Moderate	<i>Road Alignment</i>	Straight
<i>Weather Conditions</i>	Unknown	<i>Natural Lighting</i>	Dusk
<i>Number of Lanes</i>	4	<i>Street Lighting</i>	Unknown
<i>Road Division</i>	Raised median strip		

	5 km/hr reduction	10 km/hr reduction	10% reduction	20% reduction
<i>Travel Speed (km/hr)</i>	52	47	51	46
<i>Impact Speed (km/hr)</i>	35	20	34	13

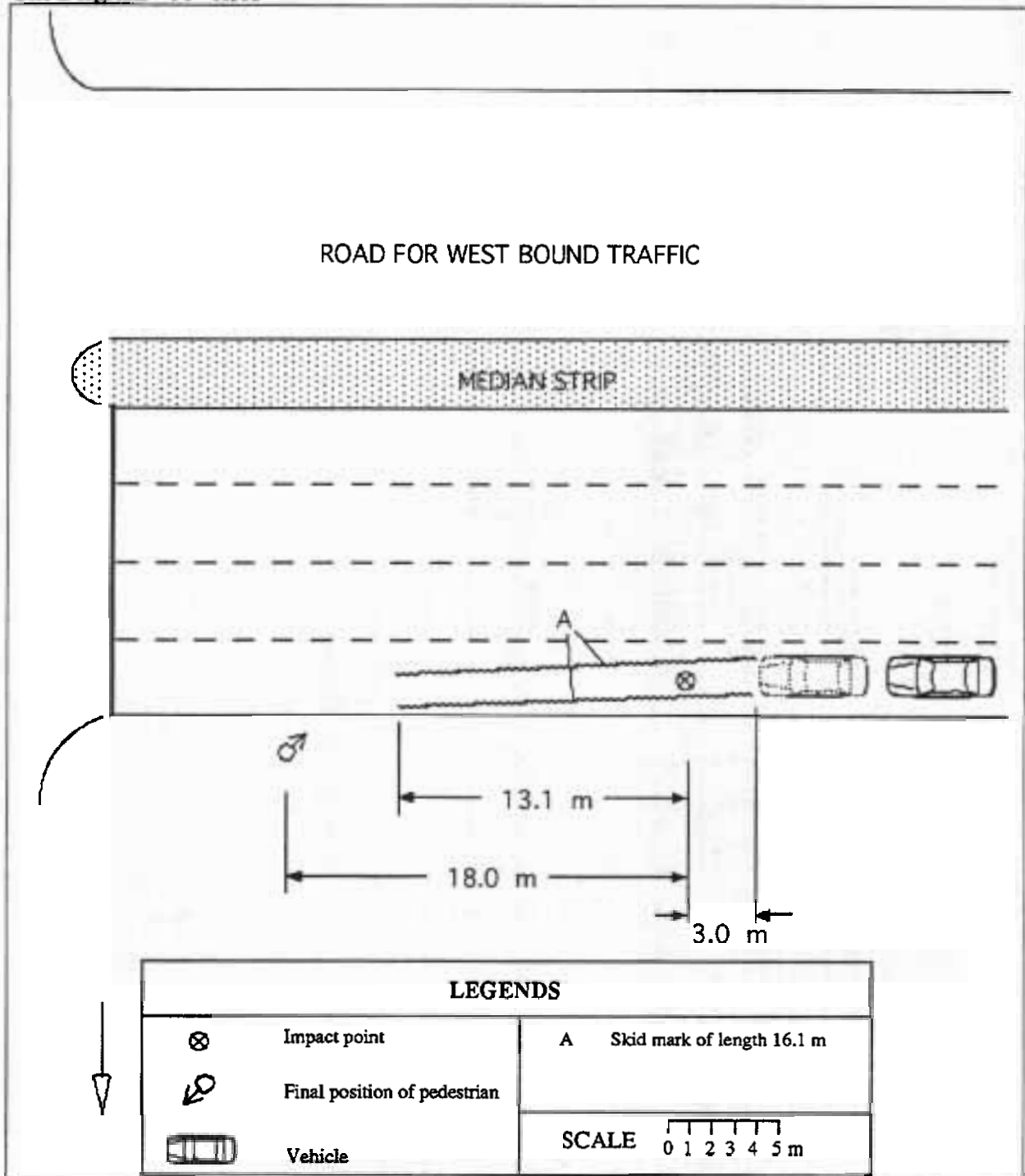

Accident Description

The car was travelling east in the far left lane when it collided with a pedestrian. The driver and witness statements were not available and so the pedestrian's movements are unknown. However the pedestrian was hit on the left hand side, indicating that he was crossing the road from south to north. Skid marks at the accident site indicated that the driver braked before impact. The calculated travel speed from the skid marks, indicated that the vehicle was travelling at about 57 km/hr.

Case Details

<i>Case Number</i>	91 - H021	<i>Calculation type</i>	3.1
<i>Date of Accident</i>	Saturday, June	<i>Time</i>	1 pm
<i>Speed Limit</i>	80 km/hr	<i>Number of Pedestrians Involved</i>	1
<i>Travel Speed</i>	40 km/hr	<i>Travel Speed Source</i>	Driver
<i>Impact Speed</i>	29 km/hr	<i>Impact Speed Source</i>	Projection distance

Pedestrian Details

<i>Fatal</i>	Yes
<i>Age</i>	71
<i>Sex</i>	Female
<i>BAC Pedestrian</i>	0 %
<i>Action</i>	Walking
<i>Movement</i>	Crossing the road
<i>Side Impacted</i>	Unknown

Driver Details

<i>Age</i>	27
<i>Sex</i>	Female
<i>BAC Driver</i>	0 %
<i>Driving Experience</i>	8 years
<i>Licence Type</i>	Full
<i>Driver Action</i>	Braked before impact

Impact Vehicle Details

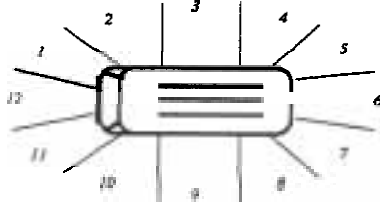
<i>Vehicle Model</i>	1986 Toyota Liteace van	
<i>Type</i>	Van	
<i>Number Involved</i>	1	
<i>Modifications</i>	Bull bar	
		<i>Impact Point</i> 11

Road Site Details

<i>Traffic Control</i>	None	<i>Road Type</i>	Arterial
<i>Traffic Conditions</i>	Light	<i>Road Alignment</i>	Straight
<i>Weather Conditions</i>	Fine, dry road	<i>Natural Lighting</i>	Day
<i>Number of Lanes</i>	3	<i>Street Lighting</i>	None
<i>Road Division</i>	Raised median strip		

Reduced Travel Speed Analysis

	5 km/hr	10 km/hr	10%	20%
<i>Travel Speed (km/hr)</i>	35	30	36	32
<i>Impact Speed (km/hr)</i>	0	0	7	0

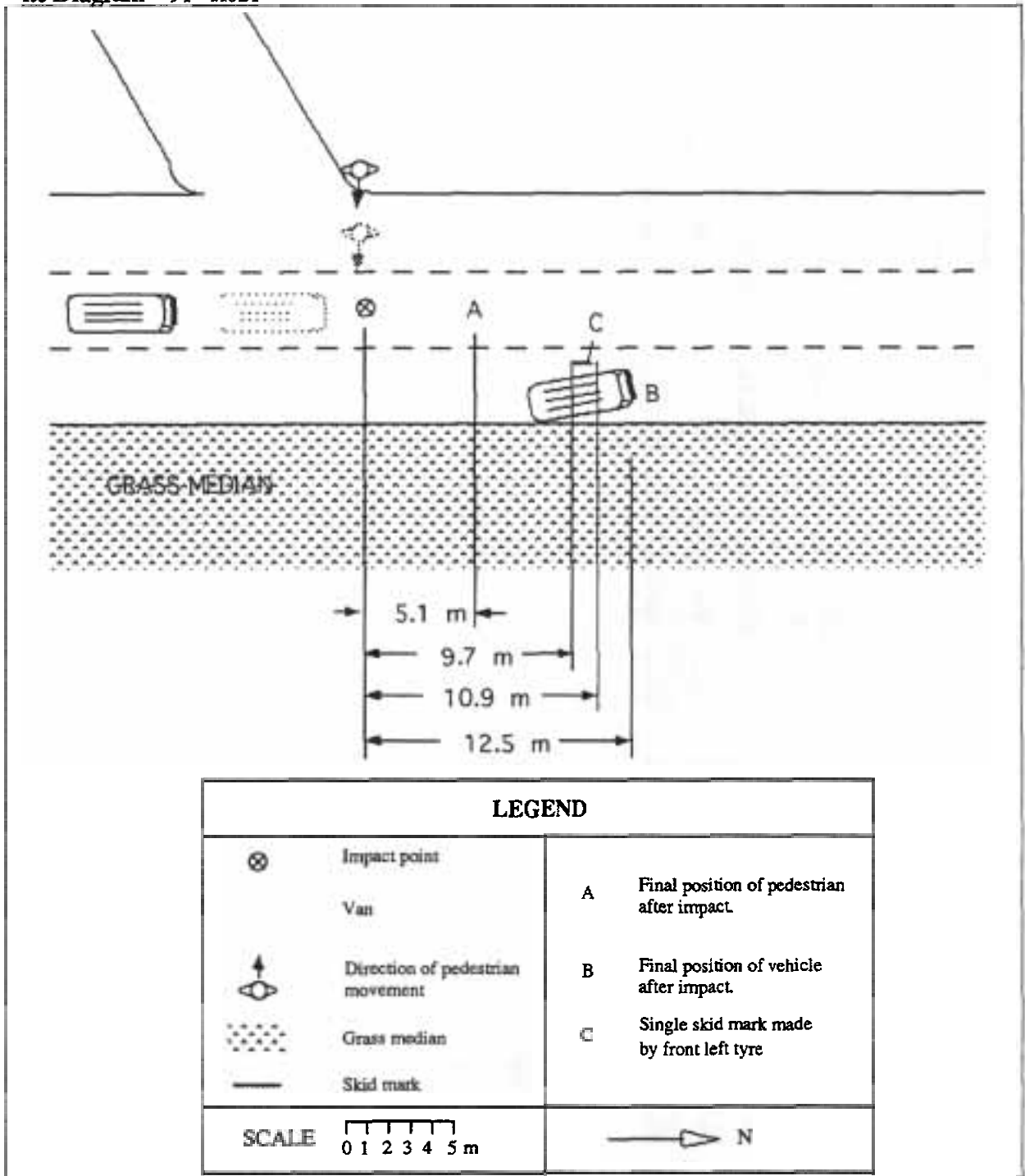

Accident Description

The van was travelling in a northerly direction at about 40 km/hr in the centre lane of a three lane road. The pedestrian, who was crossing from the driver's left walked rapidly into the path of oncoming light traffic and was struck by the left hand front corner of the van. The driver's statement was not available. From the statement of a passenger in the vehicle at the time of the accident, the driver braked and swerved to the right before impact.

Case Details

<i>Case Number</i>	91 - H022	<i>Calculation type</i>	3.1
<i>Date of Accident</i>	Tuesday, January	<i>Time</i>	8 am
<i>Speed Limit</i>	60 km/hr	<i>Number of Pedestrians Involved</i>	1
<i>Travel Speed</i>	60 km/hr	<i>Travel Speed Source</i>	Driver
<i>Impact Speed</i>	60 km/hr	<i>Impact Speed Source</i>	Projection distance

Pedestrian Details

<i>Fatal</i>	Yes
<i>Age</i>	65
<i>Sex</i>	Female
<i>BAC Pedestrian</i>	Unknown
<i>Action</i>	Walking
<i>Movement</i>	Crossing the road
<i>Side Impacted</i>	Left side to vehicle

Driver Details

<i>Age</i>	42
<i>Sex</i>	Male
<i>BAC Driver</i>	Unknown
<i>Driving Experience</i>	25 years
<i>Licence Type</i>	Full
<i>Driver Action</i>	Braked after impact

Impact Vehicle Details

<i>Vehicle Model</i>	1990 Ford Falcon sedan	<i>Impact Point</i>	11
<i>Type</i>	Car		
<i>Number Involved</i>	1		
<i>Modifications</i>	None		

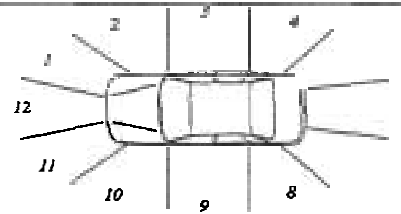

Road Site Details

<i>Traffic Control</i>	None	<i>Road Type</i>	Arterial
<i>Traffic Conditions</i>	Moderate	<i>Road Alignment</i>	Straight
<i>Weather Conditions</i>	Fine, dry road	<i>Natural Lighting</i>	Day
<i>Number of Lanes</i>	3	<i>Street Lighting</i>	None
<i>Road Division</i>	Raised median strip		

	5 km/hr reduction	10 km/hr reduction	10% reduction	20% reduction
Travel Speed (km/hr)	55	50	54	48
Impact Speed (km/hr)	49	37	47	30

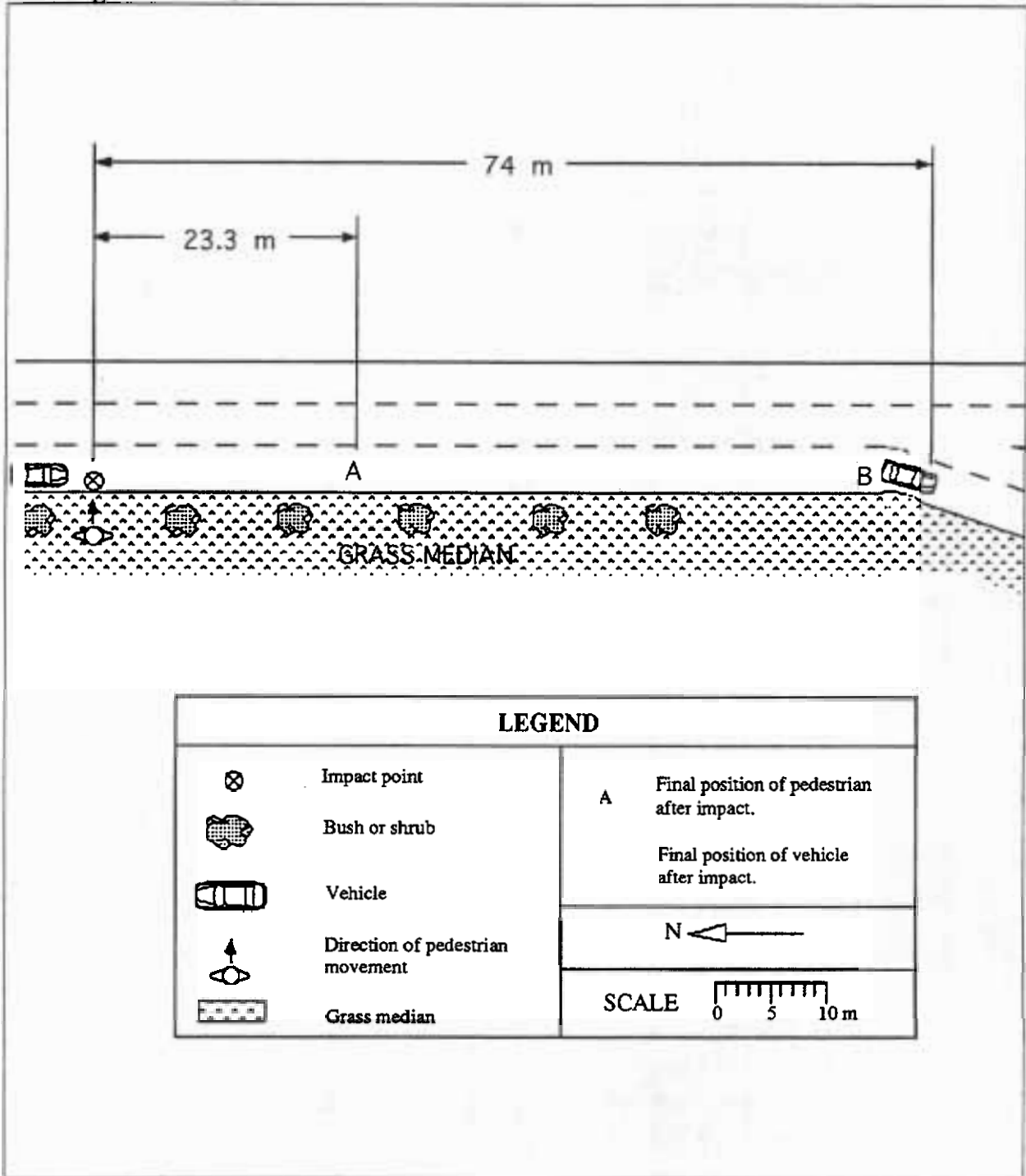

Accident Description

A pedestrian walked in an easterly direction from behind a group of bushes into the path of a vehicle travelling south. The driver stated he was travelling at about 60 km/hr in the lane closest to the raised median when a figure appeared in front of his vehicle and no evasive action was taken as he did not have time. The driver also stated that at no time prior to the collision did he see any person standing on the median strip. However, a witness travelling behind the driver saw the pedestrian about 30 metres ahead. The pedestrian was hit by the front left hand side of the vehicle and was thrown on to the bonnet before falling to the road.

Case Details

<i>Case Number</i>	91 - H023	<i>Calculation type</i>	2.1
<i>Date of Accident</i>	Friday, July	<i>Time</i>	10 pm
<i>Speed Limit</i>	60 km/hr	<i>Number of Pedestrians Involved</i>	1
<i>Travel Speed</i>	79 km/hr	<i>Travel Speed Source</i>	Skid marks
<i>Impact Speed</i>	45 km/hr	<i>Impact Speed Source</i>	Skid marks

Pedestrian Details

<i>Fatal</i>	Yes
<i>Age</i>	62
<i>Sex</i>	Male
<i>BAC Pedestrian</i>	0.159 %
<i>Action</i>	Walking
<i>Movement</i>	Crossing the road
<i>Side Impacted</i>	Left side to vehicle

Driver Details

<i>Age</i>	22
<i>Sex</i>	Male
<i>BAC Driver</i>	0 %
<i>Driving Experience</i>	Unknown
<i>Licence Type</i>	Full
<i>Driver Action</i>	Braked before impact

Impact Vehicle Details

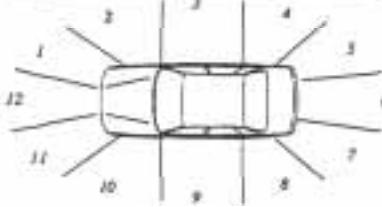
<i>Vehicle Model</i>	1982 Datsun Stanza sedan	
<i>Type</i>	Car	
<i>Number Involved</i>	1	
<i>Modifications</i>	None	

Road Site Details

<i>Traffic Control</i>	Traffic signal at intersection	<i>Road Type</i>	Arterial
<i>Traffic Conditions</i>	Moderate	<i>Road Alignment</i>	Straight
<i>Weather Conditions</i>	Fine, dry road	<i>Natural Lighting</i>	Night
<i>Number of Lanes</i>	4	<i>Street Lighting</i>	Street lights
<i>Road Division</i>	Raised median strip		

Reduced Travel Speed Analysis

	5 km/hr reduction	10 km/hr reduction	10% reduction	20% reduction
Travel Speed (km/hr)	74	69	71	64
Impact Speed (km/hr)	30	0	16	0

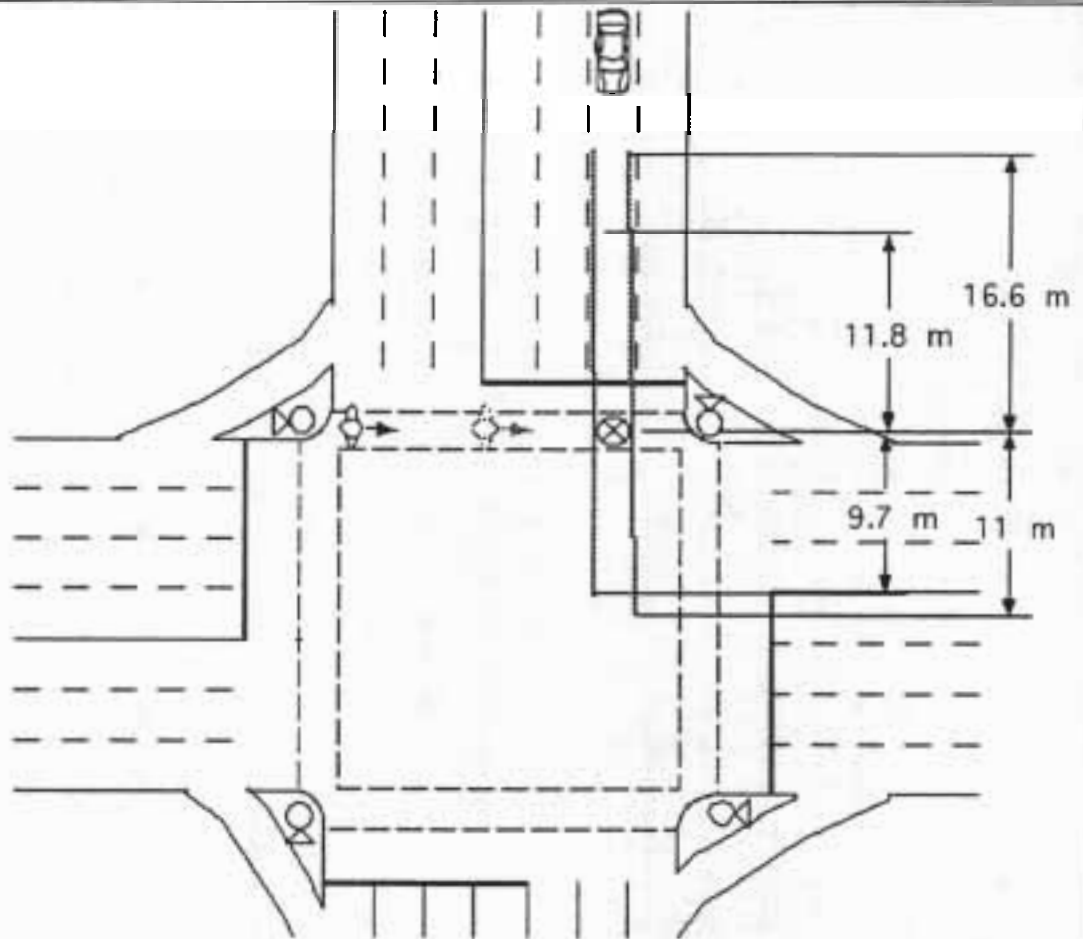

LEGEND	
	Point of impact
	Vehicle
	Direction of pedestrian movement
	Traffic lights
	A Skid marks
	N
	SCALE 0 5 10 m

Accident Description

The car was travelling east at about 79 km/hr. As the vehicle approached an intersection, the driver stated that he first saw the pedestrian about two metres in front of the car, walking in a northerly direction. The driver braked and the car skidded just before impact. The driver did not stop after the collision. From witnesses statements, the pedestrian was disobeying the 'don't walk' pedestrian signal. The front left of the vehicle struck the pedestrian on his left side. The pedestrian then was carried on the bonnet across the intersection before falling off the left side of the vehicle. The final position of the pedestrian was not recorded in the files.

Case Details

<i>Case Number</i>	91 - H025	<i>Calculation type</i>	2.1
<i>Date of Accident</i>	Sunday, August	<i>Time</i>	4 pm
<i>Speed Limit</i>	60 km/hr	<i>Number of Pedestrians Involved</i>	1
<i>Travel Speed</i>	55 km/hr	<i>Travel Speed Source</i>	Skid marks
<i>Impact Speed</i>	27 km/hr	<i>Impact Speed Source</i>	Skid marks

Pedestrian Details

<i>Fatal</i>	Yes
<i>Age</i>	9
<i>Sex</i>	Female
<i>BAC Pedestrian</i>	0 %
<i>Action</i>	Running
<i>Movement</i>	Crossing the road
<i>Side Impacted</i>	Unknown

Driver Details

<i>Age</i>	29
<i>Sex</i>	Male
<i>BAC Driver</i>	0 %
<i>Driving Experience</i>	15 years
<i>Licence Type</i>	Full
<i>Driver Action</i>	Braked before impact

Impact Vehicle Details

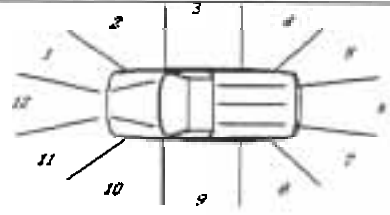
<i>Vehicle Model</i>	1985 Ford Falcon station wagon	
<i>Type</i>	Car derivative	
<i>Number Involved</i>	1	<i>Impact Point</i> 1
<i>Modifications</i>	None	

Road Site Details

<i>Traffic Control</i>	None	<i>Road Type</i>	Other main traffic route
<i>Traffic Conditions</i>	Moderate	<i>Road Alignment</i>	Straight
<i>Weather Conditions</i>	Fine, dry road	<i>Natural Lighting</i>	Day
<i>Number of Lanes</i>	1	<i>Street Lighting</i>	Not applicable
<i>Road Division</i>	None		

Reduced Travel Speed Analysis

	5 km/hr reduction	10 km/hr reduction	10% reduction	20% reduction
Travel Speed (km/hr)	50	45	50	44
Impact Speed (km/hr)	0	0	0	0

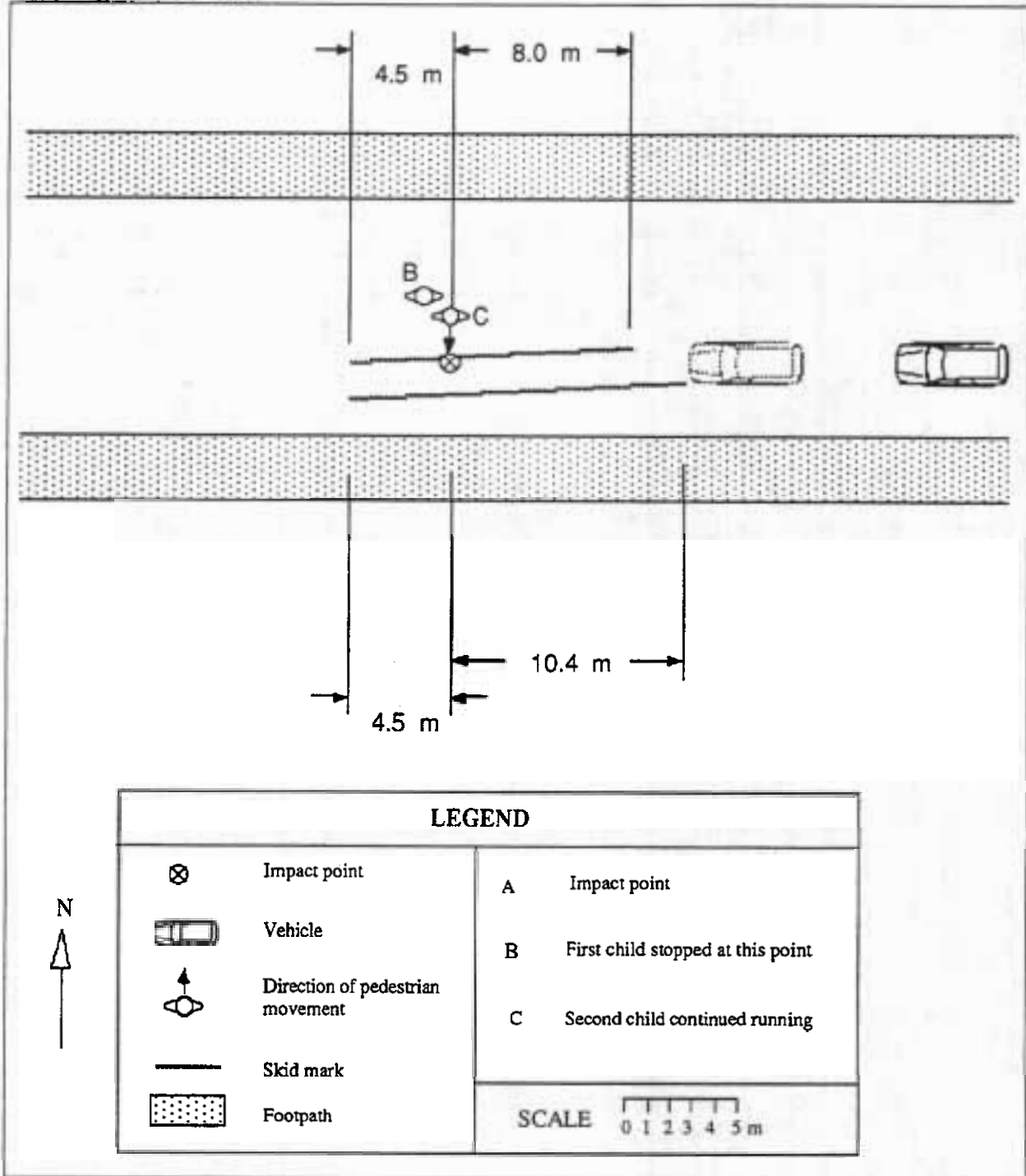

Accident Description

The car was travelling in a westerly direction at about 55 km/hr when it collided with the pedestrian who was running across the road in a southerly direction. The driver stated that he saw two children on the northern side of the road. The children ran onto the road and stopped part way across. The driver applied the brakes and sounded the horn when they started to run again. One of the children stopped but the second child continued to run across and was struck by the car.

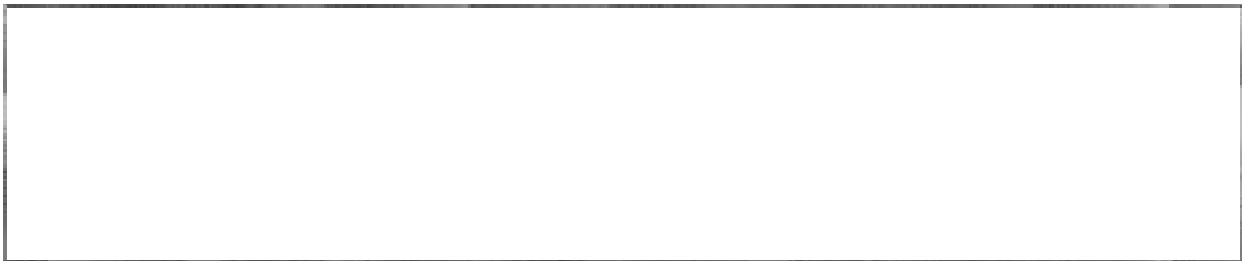

<i>Fatal</i>	Yes	<i>Age</i>	28
<i>Age</i>	80	<i>Sex</i>	Female
<i>Sex</i>	Male	<i>BAC Driver</i>	0 %
<i>BAC Pedestrian</i>	0 %	<i>Driving Experience</i>	Unknown
<i>Action</i>	Walking	<i>Licence Type</i>	Full
<i>Movement</i>	Crossing the road	<i>Driver Action</i>	Braked before impact
<i>Side Impacted</i>	Left side to vehicle		



Road Site Details

<i>Traffic Control</i>	None	<i>Road Type</i>	Arterial
<i>Traffic Conditions</i>	Heavy	<i>Road Alignment</i>	Straight
<i>Weather Conditions</i>	Fine, dry road	<i>Natural Lighting</i>	Night
<i>Number of Lanes</i>	2	<i>Street Lighting</i>	Street lights
<i>Road Division</i>	Centre line		

	5 km/hr reduction	10 km/hr reduction	10% reduction	20% reduction
Travel Speed (km/hr)	51	46	51	45
Impact Speed (km/hr)	0	0	0	0

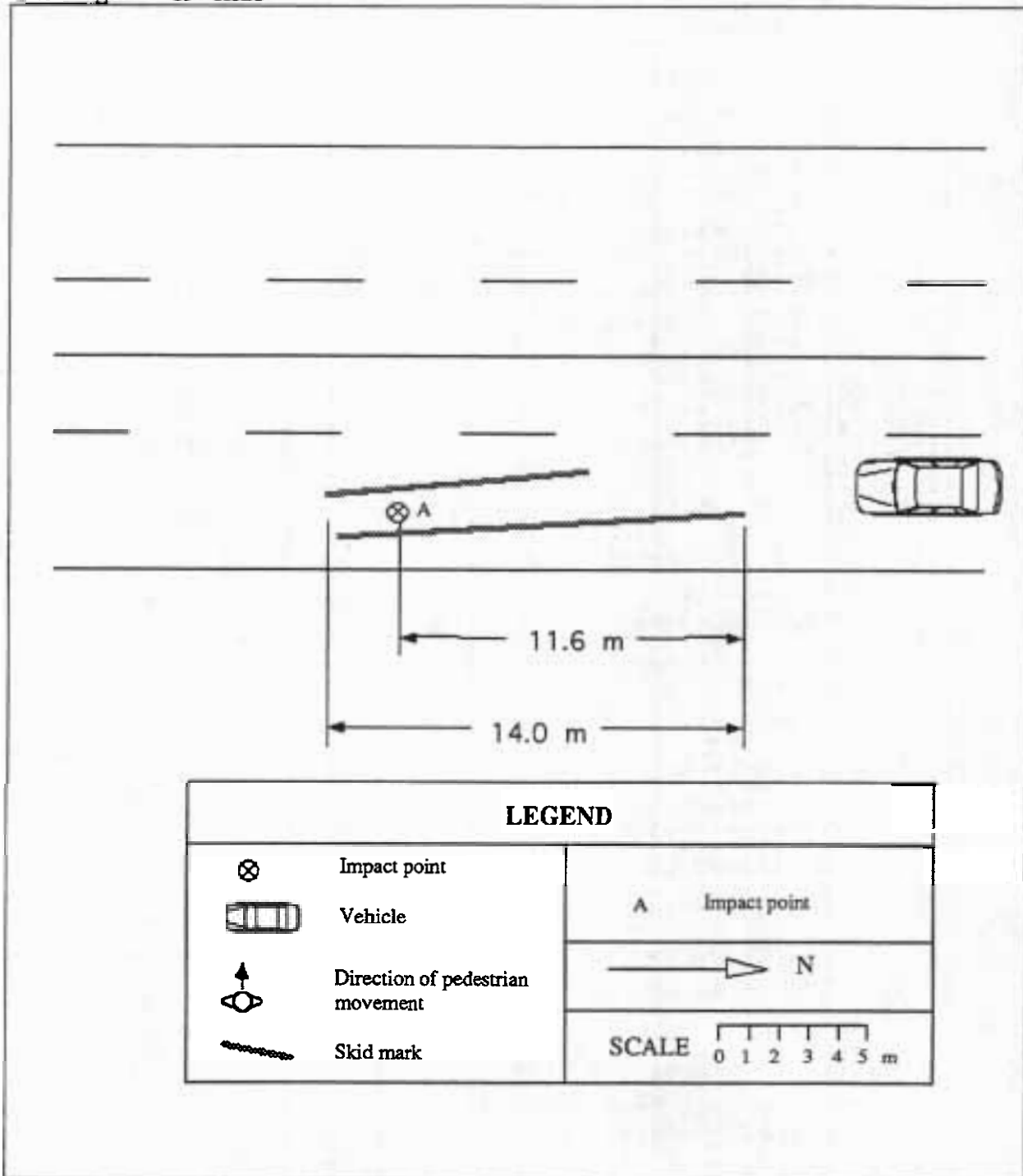

Accident Description

The car was travelling south at 56 km/hr in the left lane in heavy traffic. The driver saw a pedestrian 10 metres ahead crossing the road from west to east. The driver applied the brakes immediately, but the car slid forward hitting the pedestrian with the front of the right fender. The pedestrian was thrown up onto the bonnet and into the windscreen, before off to the right side. The car braked to a stop at point B.

Case Details

<i>Case Number</i>	89 - H022	<i>Calculation type</i>	1
<i>Date of Accident</i>	Friday, June	<i>Time</i>	12 am
<i>Speed Limit</i>	60 km/hr	<i>Number of Pedestrians Involved</i>	1
<i>Travel Speed</i>	80 km/hr	<i>Travel Speed Source</i>	Driver
<i>Impact Speed</i>	80 km/hr	<i>Impact Speed Source</i>	Driver

Pedestrian Details

<i>Fatal</i>	Yes
<i>Age</i>	35
<i>Sex</i>	Male
<i>BAC Pedestrian</i>	0 %
<i>Action</i>	Running
<i>Movement</i>	Crossing the road
<i>Side Impacted</i>	Right side to vehicle

Driver Details

<i>Age</i>	53
<i>Sex</i>	Male
<i>BAC Driver</i>	0.226 %
<i>Driving Experience</i>	34 years
<i>Licence Type</i>	Full
<i>Driver Action</i>	Braked before impact

Impact Vehicle Details

<i>Vehicle Model</i>	1989 Holden Commodore	<i>Impact Point</i>	1
<i>Type</i>	Car		
<i>Number Involved</i>	1		
<i>Modifications</i>	None		

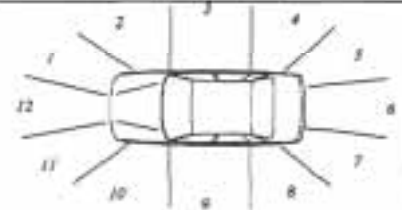

Road Site Details

<i>Traffic Control</i>	None	<i>Road Type</i>	Arterial
<i>Traffic Conditions</i>	Moderate	<i>Road Alignment</i>	Straight
<i>Weather Conditions</i>	Fine, dry road	<i>Natural Lighting</i>	Night
<i>Number of Lanes</i>	2	<i>Street Lighting</i>	Street lights
<i>Road Division</i>	Raised median strip		

Reduced Travel Speed Analysis

	5 km/hr reduction	10 km/hr reduction	10% reduction	20% reduction
Travel Speed (km/hr)	75	70	72	64
Impact Speed (km/hr)	75	70	72	64

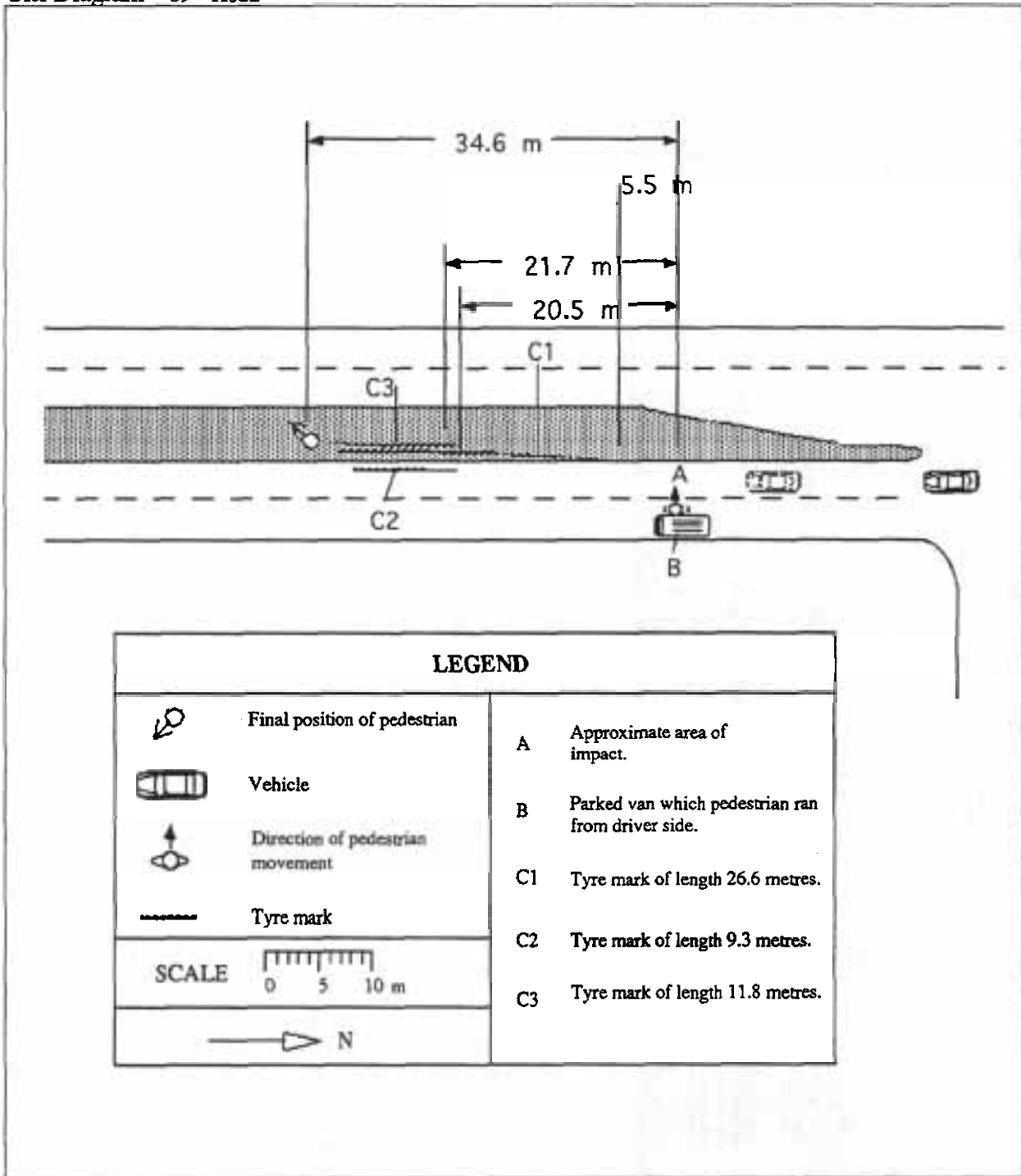

Accident Description

The car was travelling south when it collided with a pedestrian who was running across the road from a van parked on the eastern side of the road. The driver stated that he was travelling about 60 km/hr, when he saw the van 40 to 50 metres away. When about 20 to 30 metres away, he saw the pedestrian get out of the driver's side door of the van and run across the road into the path of his car. The driver also stated that he swerved right but did not brake before impact. Two independent witnesses estimated the speed of the striking car to have been in excess of 60 km/hr. One of the witnesses who was travelling between 70 to 75 km/hr estimated the striking car to have been travelling in excess of 100 km/hr when he was overtaken by it approximately 600m away from the accident site. Another witness travelling north estimated the vehicle to have been at around 80 km/hr.

Case Details

<i>Case Number</i>	85 - H043	<i>Calculation type</i>	1
<i>Date of Accident</i>	Friday, September	<i>Time</i>	12 am
<i>Speed Limit</i>	80 km/hr	<i>Number of Pedestrians Involved</i>	2
<i>Travel Speed</i>	90 km/hr	<i>Travel Speed Source</i>	Driver
<i>Impact Speed</i>	90 km/hr	<i>Impact Speed Source</i>	Driver

Pedestrian 1 Details

<i>Fatal</i>	Yes
<i>Age</i>	23
<i>Sex</i>	Male
<i>BAC Pedestrian</i>	0.175 %
<i>Action</i>	Walking
<i>Movement</i>	Pushing vehicle
<i>Side Impacted</i>	Unknown

Pedestrian 2 Details

<i>Fatal</i>	No
<i>Age</i>	Unknown
<i>Sex</i>	Male
<i>BAC Pedestrian</i>	Unknown
<i>Action</i>	Walking
<i>Movement</i>	Pushing vehicle
<i>Side Impacted</i>	Unknown

Driver Details

<i>Age</i>	28	<i>Driving Experience</i>	11 years	<i>Driver Action</i>	Braked after impact
<i>Sex</i>	Male	<i>Licence Type</i>	Full		
		<i>BAC Driver</i>	0.185 %		

Impact Vehicle Details

<i>Vehicle Model</i>	1967 Holden utility	<i>Impact Point</i>	11
<i>Type</i>	Car derivative		
<i>Number Involved</i>	1		
<i>Modifications</i>	None		

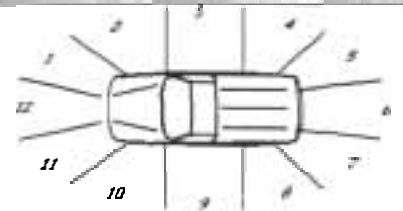

Road Site Details

<i>Traffic Control</i>	None	<i>Road Type</i>	Arterial
<i>Traffic Conditions</i>	Light	<i>Road Alignment</i>	Straight
<i>Weather Conditions</i>	Fine, dry road	<i>Natural Lighting</i>	Night
<i>Number of Lanes</i>	1	<i>Street Lighting</i>	None
<i>Road Division</i>	Raised median strip		

Reduced Travel Speed Analysis

	5 km/hr reduction	10 km/hr reduction	10% reduction	20% reduction
Travel Speed (km/hr)	85	80	81	72
Impact Speed (km/hr)	85	80	81	72

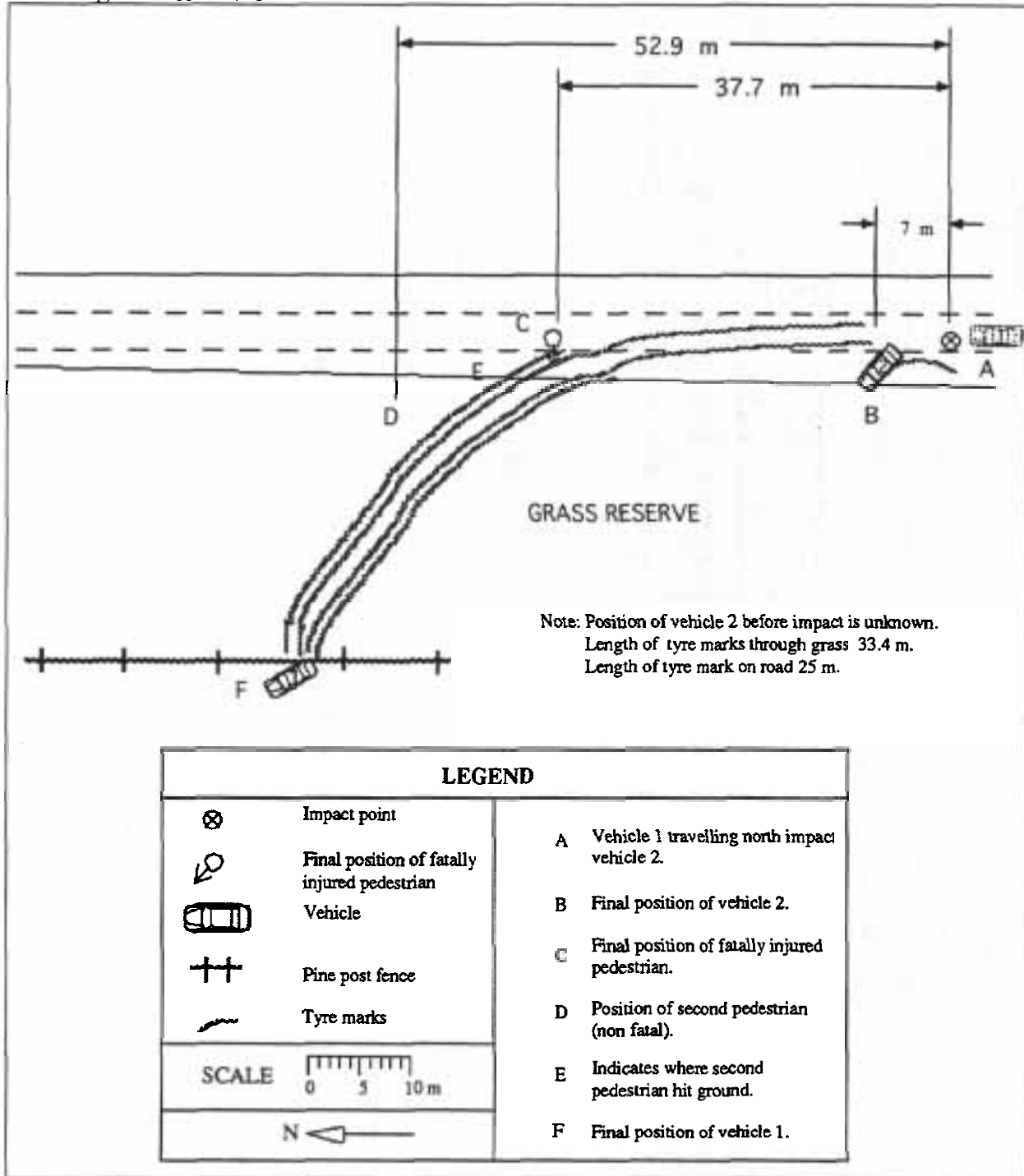

Accident Description

Vehicle 2 (1973 Chrysler Charger Coupe) had been doing "wheelies" on a nature strip and was assumed to have stalled. It was being pushed off the road by two persons, both believed to be on the right hand side of vehicle 2. Vehicle 2 was then struck on the right hand side door by vehicle 1 which was travelling north in the left lane. The driver of vehicle 1 stated that he was travelling about 90 km/hr and did not see the pedestrians or the vehicle prior to impact. Vehicle 2 was rotated about 90 degrees anticlockwise by the impact. The fatally injured pedestrian came to rest on the road about 38 metres from the impact point. The survivor is believed to have bounced on edge of the road 40 metres from the impact point before coming to rest about 13 m further on. Vehicle 1 continued on a curved trajectory with all wheels sliding and came to rest after crossing the nature strip, going through a fence and hitting a kerb in the motel grounds.

Case Details

<i>Case Number</i>	85 - H052	<i>Calculation type</i>	1
<i>Date of Accident</i>	Sunday, October	<i>Time</i>	2 am
<i>Speed Limit</i>	60 km/hr	<i>Number of Pedestrians Involved</i>	2
<i>Travel Speed</i>	80 km/hr	<i>Travel Speed Source</i>	Witness
<i>Impact Speed</i>	80 km/hr	<i>Impact Speed Source</i>	Witness

Pedestrian 1 Details

<i>Fatal</i>	Yes
<i>Age</i>	21
<i>Sex</i>	Female
<i>BAC Pedestrian</i>	0.067 %
<i>Action</i>	Standing
<i>Movement</i>	Not applicable
<i>Side Impacted</i>	Left side to vehicle

Pedestrian 2 Details

<i>Fatal</i>	No
<i>Age</i>	Unknown
<i>Sex</i>	Unknown
<i>BAC Pedestrian</i>	Unknown
<i>Action</i>	Standing
<i>Movement</i>	Not applicable
<i>Side Impacted</i>	Left side to vehicle

Driver Details

<i>Age</i>	28	<i>Driving Experience</i>	12 years	<i>Driver Action</i>	No evasive action
<i>Sex</i>	Male	<i>Licence Type</i>	Full		
		<i>BAC Driver</i>	0 %		

Impact Vehicle Details

<i>Vehicle Model</i>	1977 Chrysler panel van	<i>Impact Point</i>	1
<i>Type</i>	Car		
<i>Number Involved</i>	2		
<i>Modifications</i>	None		

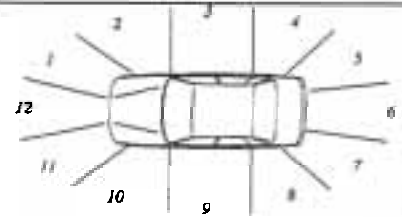

Road Site Details

<i>Traffic Control</i>	None	<i>Road Type</i>	Other main traffic route
<i>Traffic Conditions</i>	Light		
<i>Weather Conditions</i>	Fine, dry road	<i>Road Alignment</i>	Curved
<i>Number of Lanes</i>	1	<i>Natural Lighting</i>	Night
<i>Road Division</i>	None	<i>Street Lighting</i>	Street lights

Reduced Travel Speed Analysis

	5 km/hr reduction	10 km/hr reduction	10% reduction	20% reduction
Travel Speed (km/hr)	75	70	72	64
Impact Speed (km/hr)	75	70	72	64

Site Diagram 85 - H052

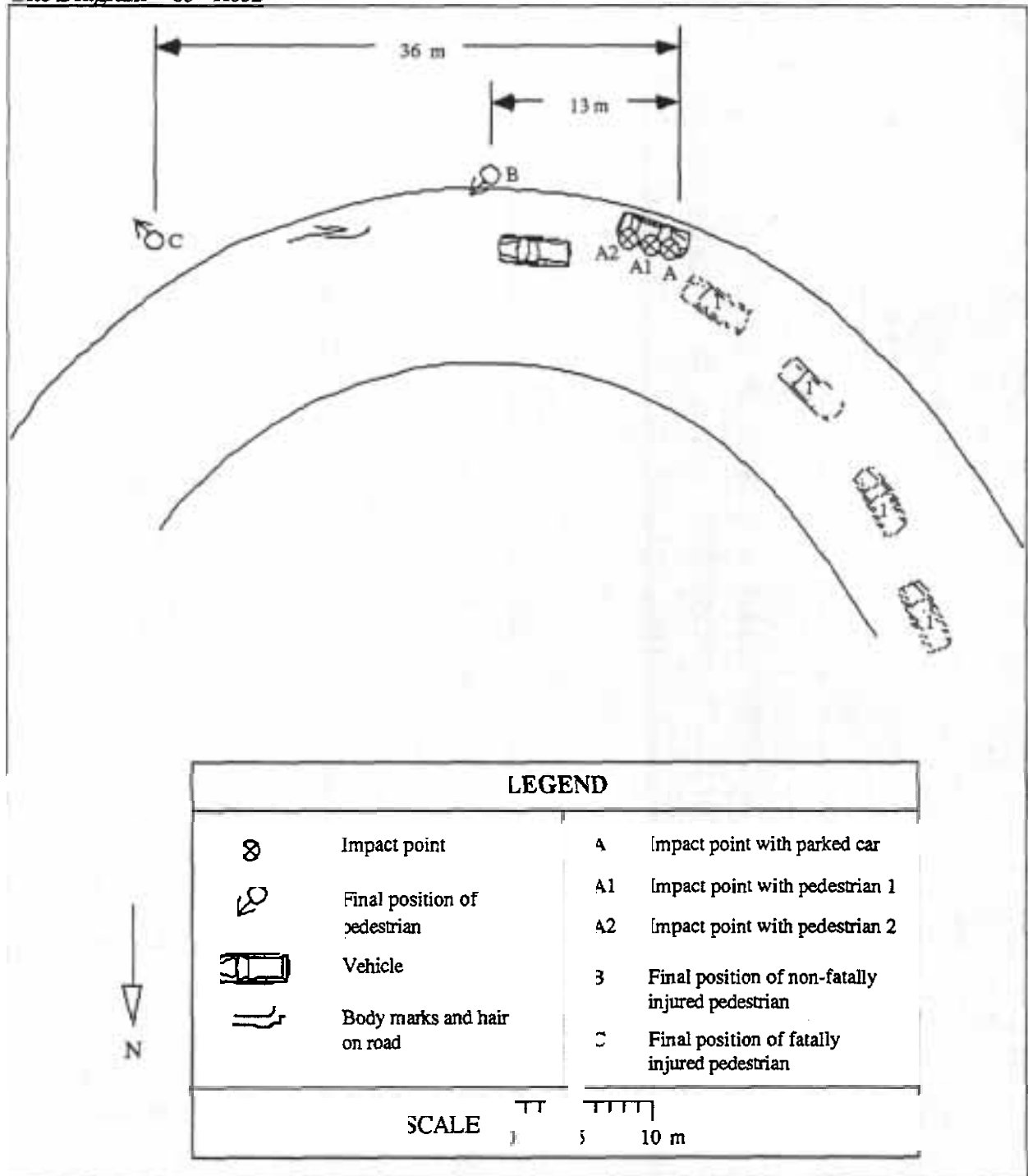

Accident Description

Vehicle 1 was travelling at about 80 km/hr around a bend. The car was travelling on the wrong side of the road when it struck a parked car at point A. It then collided with two pedestrians (at points A1 and A2) who were standing by the car. The non fatally injured pedestrian was thrown to point B and the fatally injured one came to rest at point C. The driver did not stop at the collision.

Case Details

<i>Case Number</i>	85 - H065	<i>Calculation type</i>	2.1
<i>Date of Accident</i>	Saturday, November	<i>Time</i>	10 pm
<i>Speed Limit</i>	60 km/hr	<i>Number of Pedestrians Involved</i>	2
<i>Travel Speed</i>	94 km/hr	<i>Travel Speed Source</i>	Skid marks
<i>Impact Speed</i>	73 km/hr	<i>Impact Speed Source</i>	Skid marks

Pedestrian 1 Details

<i>Fatal</i>	Yes
<i>Age</i>	39
<i>Sex</i>	Male
<i>BAC Pedestrian</i>	0%
<i>Action</i>	Running
<i>Movement</i>	Crossing the road
<i>Side Impacted</i>	Right side to vehicle

Pedestrian 2 Details

<i>Fatal</i>	No
<i>Age</i>	Unknown
<i>Sex</i>	Male
<i>BAC Pedestrian</i>	Unknown
<i>Action</i>	Running
<i>Movement</i>	Crossing the road
<i>Side Impacted</i>	Not applicable

Driver Details

<i>Age</i>	19	<i>Driving Experience</i>	3 years	<i>Driver Action</i>	Braked before impact
<i>Sex</i>	Male	<i>Licence Type</i>	Full		
		<i>BAC Driver</i>	0%		

Impact Vehicle Details

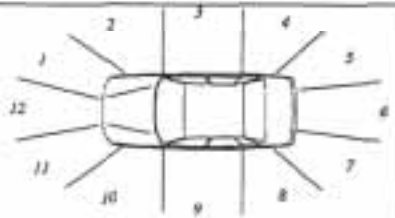
<i>Vehicle Model</i>	1971 Chrysler Ranger station wagon	
<i>Type</i>	Car	
<i>Number Involved</i>	1	
<i>Modifications</i>	None	

Road Site Details

<i>Traffic Control</i>	None	<i>Road Type</i>	Arterial
<i>Traffic Conditions</i>	Light	<i>Road Alignment</i>	Straight
<i>Weather Conditions</i>	Fine, dry road	<i>Natural Lighting</i>	Night
<i>Number of Lanes</i>	1	<i>Street Lighting</i>	Street lights
<i>Road Division</i>	Centre line		

Reduced Travel Speed Analysis

	5 km/hr reduction	10 km/hr reduction	10% reduction	20% reduction
Travel Speed (km/hr)	89	84	85	76
Impact Speed (km/hr)	63	53	54	28

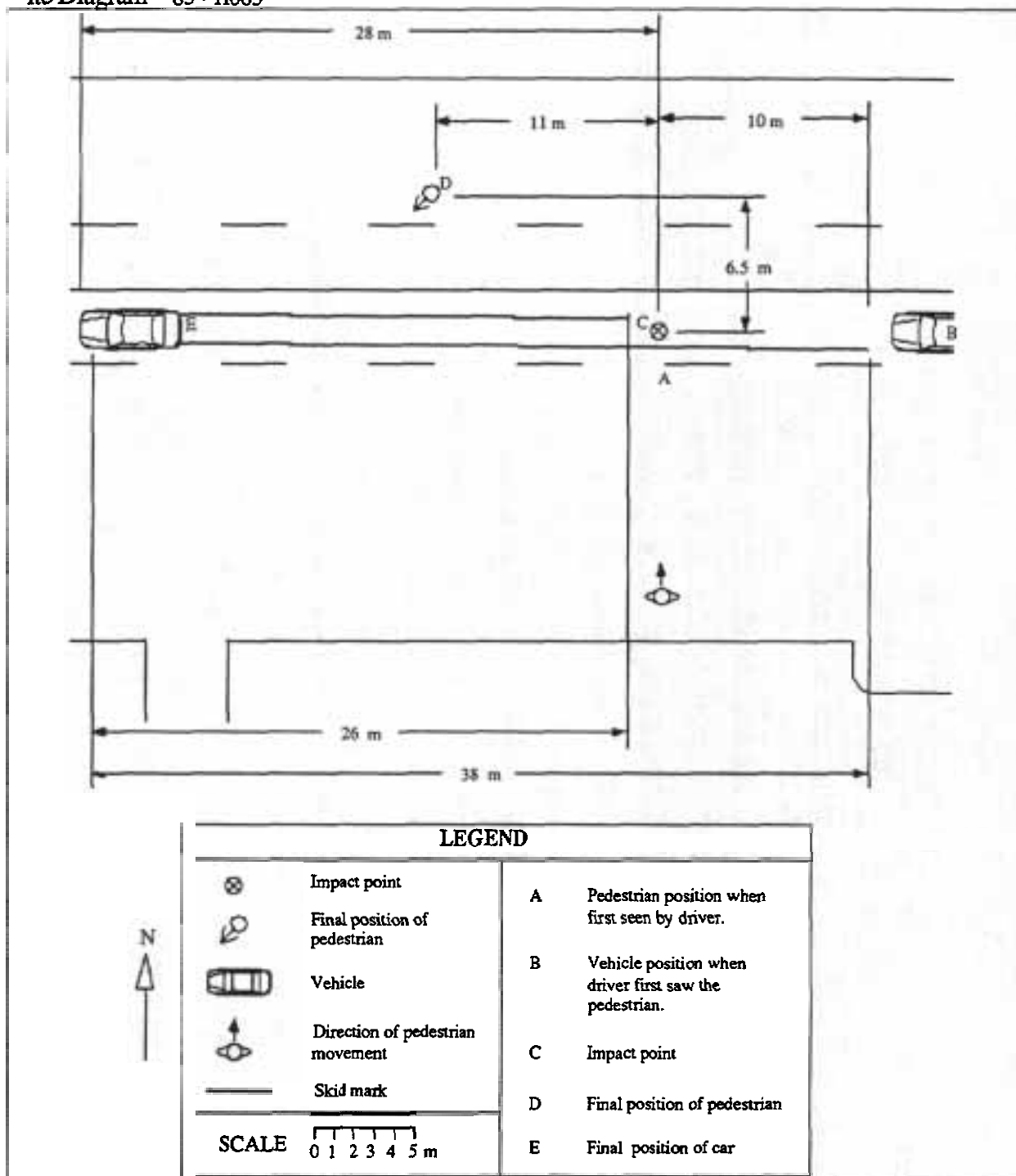

Accident Description

The vehicle was travelling in a westerly direction in the right hand lane at a speed estimated to be 94 km/hr. Two pedestrians were running across the road in a northerly direction and stopped on the lane marking at point A to let a car go past. The pedestrians then ran behind this car. The driver of vehicle 1 (at point E) saw the pedestrians at point A, 2 to 3 car lengths away. He thought they were waiting for all the traffic to pass, and when they ran in front of his vehicle he braked hard, locking the front left tyre. The first pedestrian made it to the median strip and continued to cross the road. The second pedestrian was hit by the car at point C, with the right side of the front of the car striking his right hand side. The pedestrian's head struck the plenum chamber at the base of the windscreen. He then fell off the right side of the car coming to rest at point D. The car stopped at point E.

Case Details

<i>Case Number</i>	89 - H009	<i>Calculation type</i>	1
<i>Date of Accident</i>	Wednesday, February	<i>Time</i>	9 pm
<i>Speed Limit</i>	60 km/hr	<i>Number of Pedestrians Involved</i>	2
<i>Travel Speed</i>	60 km/hr	<i>Travel Speed Source</i>	Driver
<i>Impact Speed</i>	60 km/hr	<i>Impact Speed Source</i>	Driver

Pedestrian 1 Details

<i>Fatal</i>	Yes
<i>Age</i>	38
<i>Sex</i>	Male
<i>BAC Pedestrian</i>	0%
<i>Action</i>	Standing
<i>Movement</i>	Crossing the road
<i>Side Impacted</i>	Right side to vehicle

Pedestrian 2 Details

<i>Fatal</i>	No
<i>Age</i>	29
<i>Sex</i>	Female
<i>BAC Pedestrian</i>	Unknown
<i>Action</i>	Standing
<i>Movement</i>	Crossing the road
<i>Side Impacted</i>	Right side to vehicle

Driver Details

<i>Age</i>	19	<i>Driving Experience</i>	2 years	<i>Driver Action</i>	No evasive action
<i>Sex</i>	Male	<i>Licence Type</i>	Full		
		<i>BAC Driver</i>	0%		

Impact Vehicle Details

<i>Vehicle Model</i>	1973 Holden Torana sedan	<i>Impact Point</i>	12
<i>Type</i>	Car		
<i>Number Involved</i>	2		
<i>Modifications</i>	None		

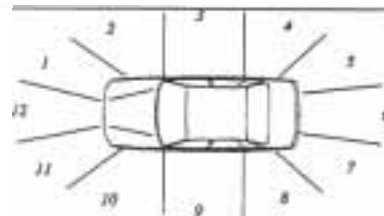

Road Site Details

<i>Traffic Control</i>	None	<i>Road Type</i>	Arterial
<i>Traffic Conditions</i>	Moderate	<i>Road Alignment</i>	Straight
<i>Weather Conditions</i>	Fine, dry road	<i>Natural Lighting</i>	Night
<i>Number of Lanes</i>	1	<i>Street Lighting</i>	Street lights
<i>Road Division</i>	Centre line		

Reduced Travel Speed Analysis

	5 km/hr reduction	10 km/hr reduction	10% reduction	20% reduction
Travel Speed (km/hr)	55	50	54	48
Impact Speed (km/hr)	55	50	54	48

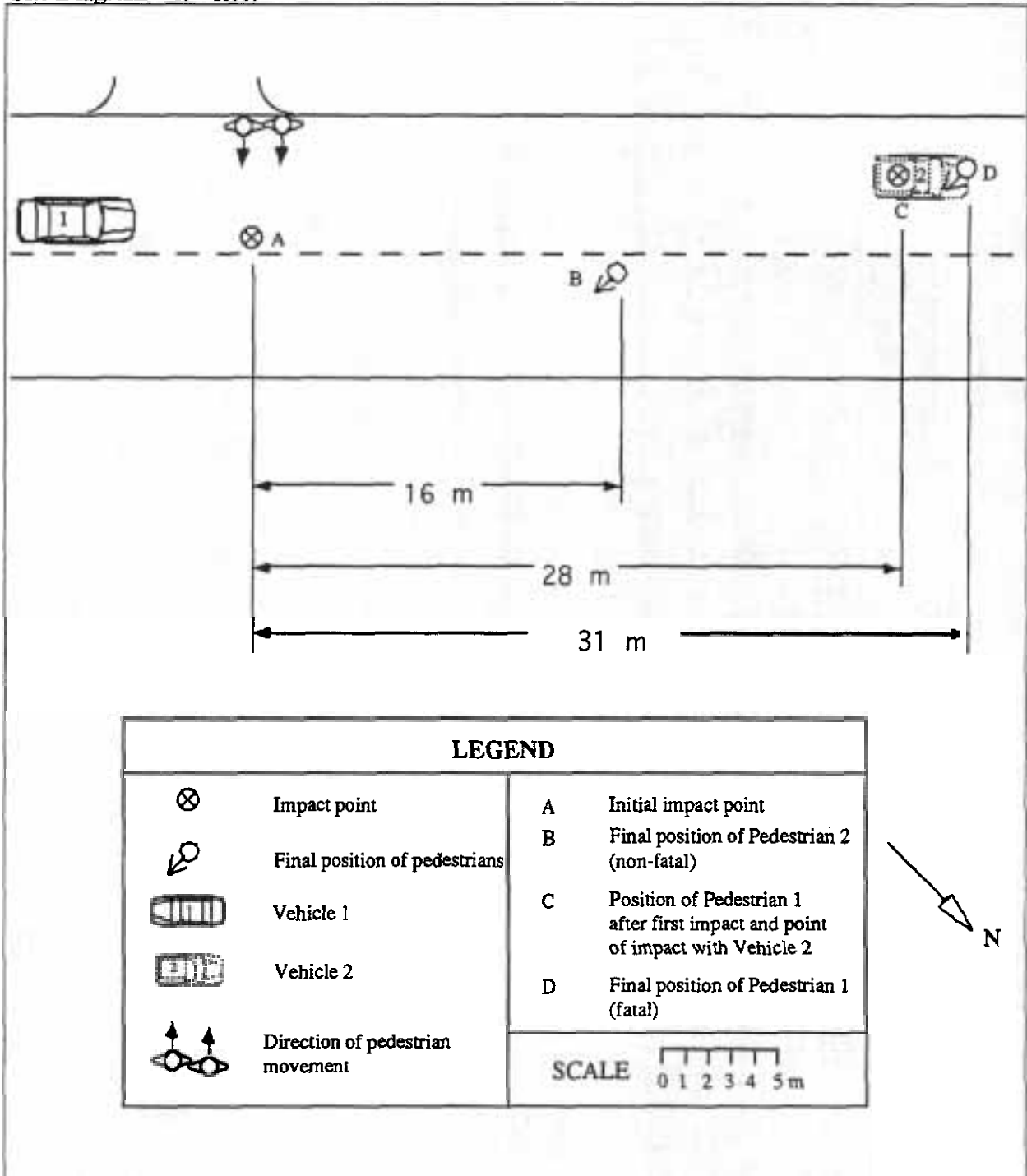

Accident Description

Vehicle 1 was travelling in a north westerly direction at 60 km/hr. Two pedestrians were crossing the road in a north easterly direction and had stopped in the centre of the road. The driver of Vehicle 1 did not see the pedestrians and collided with them at point A. Pedestrian 2 (non-fatal) was thrown to the right landing at point B. Pedestrian 1 (fatal) was struck by the front of the vehicle on his right hand side, then struck the windscreen and fell off to the right side of the car coming to rest at point C. Vehicle 1 stopped and pulled to the side of the road. Vehicle 2 was travelling also in a north westerly direction and was distracted by the pedestrian on the eastern side of the road. The driver of Vehicle 2 did not see pedestrian 1 and she ran over him with the front wheels (at point C) rolling the body to point D. The car was lifted off the pedestrian.

Case Details

<i>Case Number</i>	84 - H044	<i>Calculation type</i>	1
<i>Date of Accident</i>	Thursday, November	<i>Time</i>	9 pm
<i>Speed Limit</i>	60 km/hr	<i>Number of Pedestrians Involved</i>	3
<i>Travel Speed</i>	73 km/hr	<i>Travel Speed Source</i>	Skid marks
<i>Impact Speed</i>	73 km/hr	<i>Impact Speed Source</i>	Skid marks

Pedestrian 1 Details

<i>Fatal</i>	Yes
<i>Age</i>	76
<i>Sex</i>	Female
<i>BAC</i>	0 %
<i>Action</i>	Walking
<i>Movement</i>	Crossing the road
<i>Side Impacted</i>	Left side to vehicle

Pedestrian 2 Details

<i>Fatal</i>	Yes
<i>Age</i>	60
<i>Sex</i>	Female
<i>BAC</i>	0 %
<i>Action</i>	Walking
<i>Movement</i>	Crossing the road
<i>Side Impacted</i>	Left side

Pedestrian 3 Details

<i>Fatal</i>	Yes
<i>Age</i>	81
<i>Sex</i>	Female
<i>BAC</i>	0 %
<i>Action</i>	Walking
<i>Movement</i>	Crossing the road
<i>Side Impacted</i>	Left side

Driver Details

<i>Age</i>	33	<i>Driving Experience</i>	17 years	<i>Driver Action</i>	Braked after impact
<i>Sex</i>	Male	<i>Licence Type</i>	Full		
		<i>BAC Driver</i>	0 %		

Impact Vehicle Details

<i>Vehicle Model</i>	1976 Chrysler Galant sedan		
<i>Type</i>	Car	<i>Impact Point</i>	12
<i>Number Involved</i>	1		
<i>Modifications</i>	None		

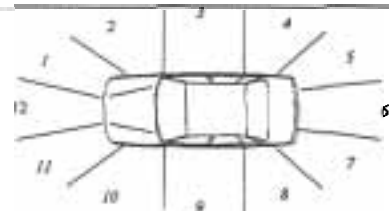

Road Site Details

<i>Traffic Control</i>	None	<i>Road Type</i>	Arterial
<i>Traffic Conditions</i>	Light	<i>Road Alignment</i>	Straight
<i>Weather Conditions</i>	Fine, dry road	<i>Natural Lighting</i>	Night
<i>Number of Lanes</i>	2	<i>Street Lighting</i>	Street lights plus other off street lighting
<i>Road Division</i>	Painted median strip		

Reduced Travel Speed Analysis

	5 km/hr reduction	10 km/hr reduction	10% reduction	20% reduction
Travel Speed (km/hr)	68	63	65	58
Impact Speed (km/hr)	68	63	65	58

Site Diagram 84 - H044

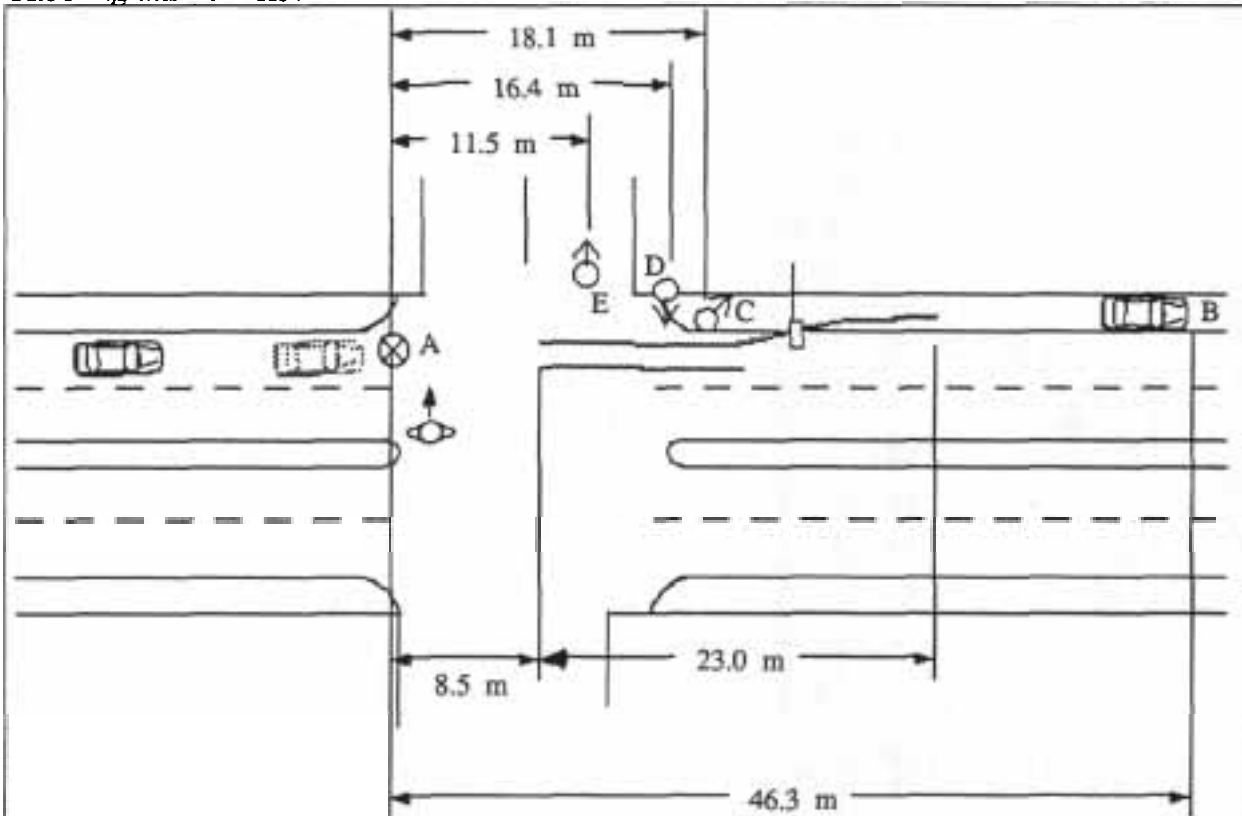

LEGEND	
	Impact point
	Final position of pedestrian
	Street light
	Striking vehicle
	Direction of pedestrians movement
SCALE	

Accident Description

The car was travelling in a northerly direction in the left hand lane of a dual lane carriageway, at about 73 km/hr. Two pedestrians were being helped across the road by a third because of their age. They were crossing slowly in a westerly direction and were in a staggered formation. The driver did not see the pedestrians and hit them with full force at point A. All three were hit by the front of the car and they came to rest at points C (pedestrian 1), D (pedestrian 2) and E (pedestrian 3). The driver then braked and the car swerved up onto the footpath before coming to rest at point B.

Case Details

<i>Case Number</i>	84 - H005	<i>Case type</i>	Insufficient information
<i>Date of Accident</i>	Thursday, April	<i>Time</i>	1 pm
<i>Speed Limit</i>	60 km/hr	<i>Number of Pedestrians Involved</i>	1
<i>Travel Speed</i>	45 km/hr	<i>Travel Speed Source</i>	Driver

Pedestrian Details

<i>Fatal</i>	Yes
<i>Age</i>	74
<i>Sex</i>	Male
<i>BAC Pedestrian</i>	Unknown %
<i>Action</i>	Running
<i>Movement</i>	Crossing the road
<i>Side Impacted</i>	Right side to vehicle

Driver Details

<i>Age</i>	Unknown
<i>Sex</i>	Unknown
<i>BAC Driver</i>	Unknown %
<i>Driving Experience</i>	Unknown years
<i>Licence Type</i>	Unknown
<i>Driver Action</i>	Unknown

Impact Vehicle Details

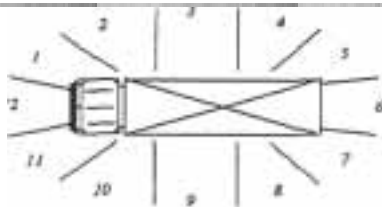
<i>Vehicle Model</i>	Ford Heavy Truck	
<i>Type</i>	Truck	
<i>Number Involved</i>	1	
<i>Modifications</i>	None	

Road Site Details

<i>Traffic Control of Area</i>	None	<i>Road Type</i>	Arterial
<i>Traffic Conditions</i>	Moderate	<i>Road Alignment</i>	Straight
<i>Weather Conditions</i>	Fine, dry road	<i>Natural Lighting</i>	Day
<i>Number of Lanes</i>	2	<i>Street Lighting</i>	None
<i>Road Division</i>	Raised median strip		

Site Diagram

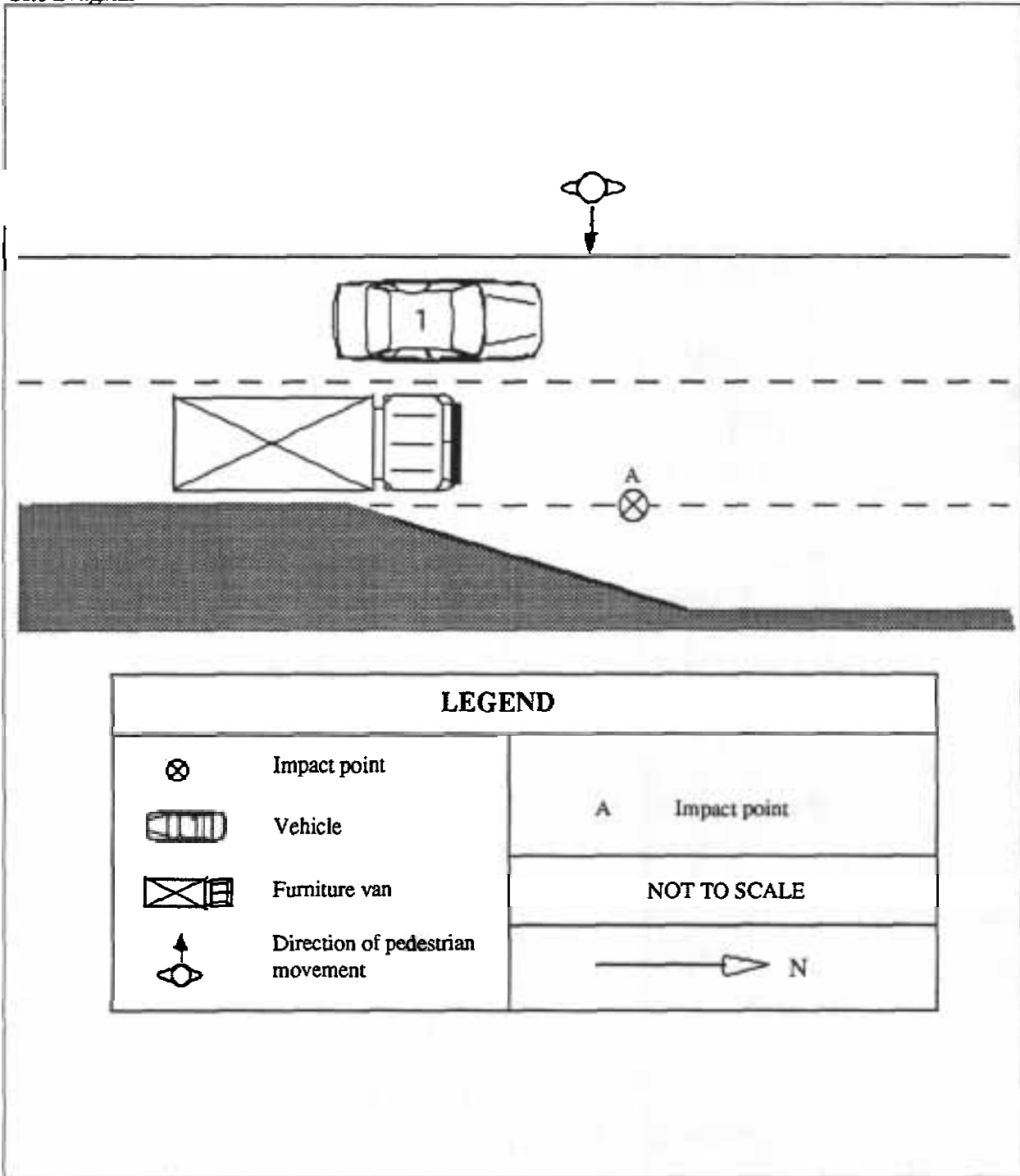

Accident Description

The pedestrian ran from the footpath in front of a vehicle travelling in the left lane. The vehicle braked heavily and the pedestrian ran into the next lane and was hit by a furniture van.

Case Details

<i>Case Number</i>	85 - H026	<i>Case type</i>	Insufficient information
<i>Date of Accident</i>	Tuesday, May	<i>Time</i>	11 pm
<i>Speed Limit</i>	60 km/hr	<i>Number of Pedestrians Involved</i>	1
<i>Travel Speed</i>	Unknown km/hr	<i>Travel Speed Source</i>	Unknown

Pedestrian Details

<i>Fatal</i>	Yes
<i>Age</i>	Unknown
<i>Sex</i>	Unknown
<i>BAC Pedestrian</i>	Unknown %
<i>Action</i>	Unknown
<i>Movement</i>	Unknown
<i>Side Impacted</i>	Unknown

Driver Details

<i>Age</i>	Unknown
<i>Sex</i>	Unknown
<i>BAC Driver</i>	Unknown %
<i>Driving Experience</i>	Unknown years
<i>Licence Type</i>	Unknown
<i>Driver Action</i>	Unknown

Impact Vehicle Details

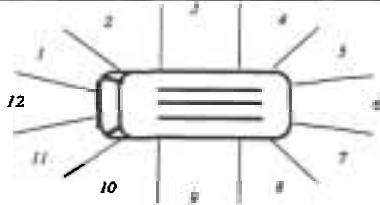
<i>Vehicle Model</i>	Mazda E1600 van	
<i>Type</i>	Van	
<i>Number Involved</i>	1	
<i>Modifications</i>	Bull Bar	
<i>Impact Point</i>	12	

Road Site Details

<i>Traffic Control of Area</i>	Traffic signal at intersection	<i>Road Type</i>	Arterial
<i>Traffic Conditions</i>	Unknown	<i>Road Alignment</i>	Straight
<i>Weather Conditions</i>	Unknown	<i>Natural Lighting</i>	Night
<i>Number of Lanes</i>	3	<i>Street Lighting</i>	Street lights
<i>Road Division</i>	Raised median strip		

Site Diagram

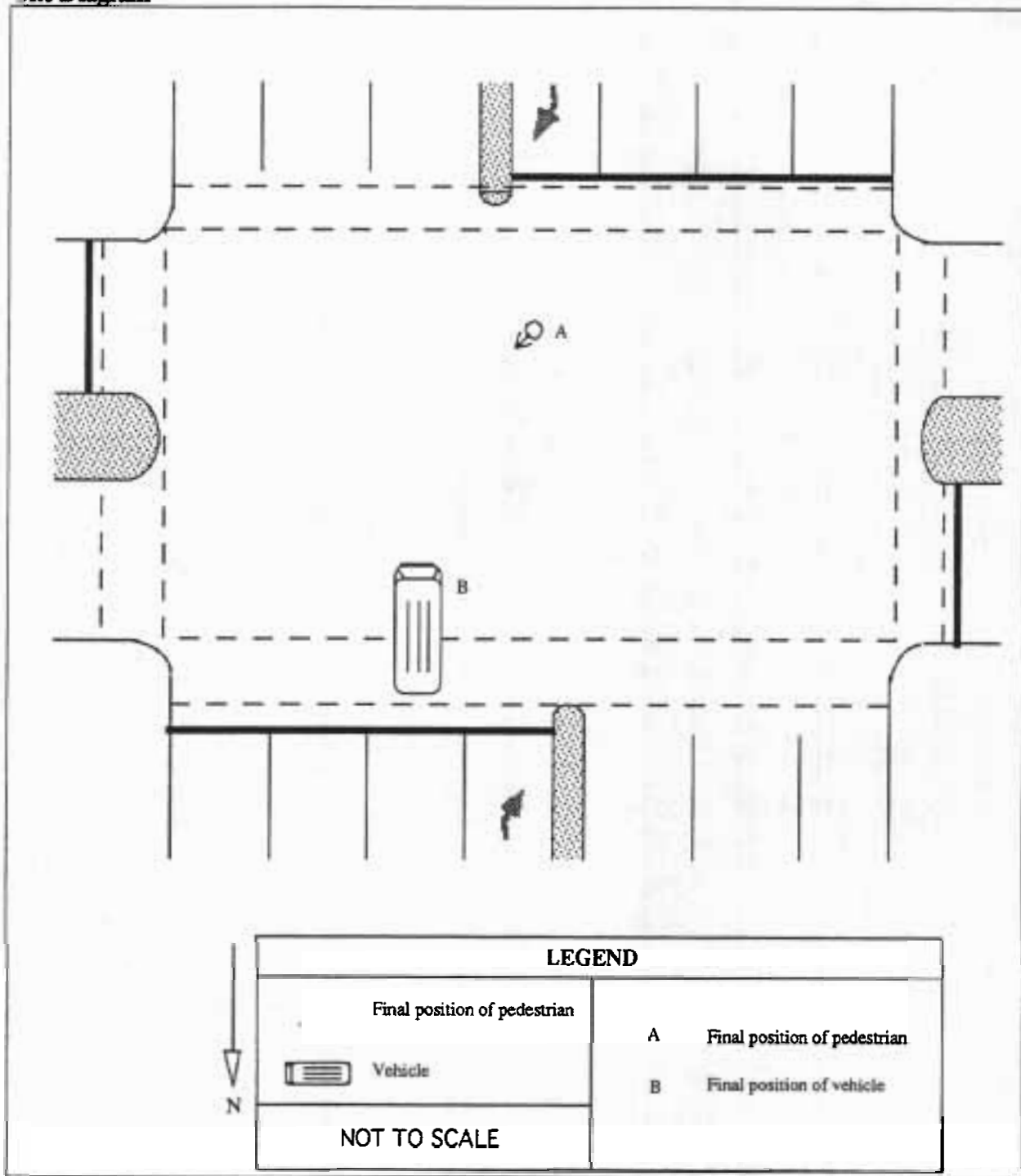

Accident Description

No more information available than that given above. Police report was not available. Only the final body and final car position were known. Vehicle travel and impact speed could not be estimated.

Case Details

<i>Case Number</i>	86 - H024	<i>Case type</i>	Off road
<i>Date of Accident</i>	Friday, April	<i>Time</i>	7 pm
<i>Speed Limit</i>	110 km/hr	<i>Number of Pedestrians Involved</i>	1
<i>Travel Speed</i>	69 km/hr	<i>Travel Speed Source</i>	Police

Pedestrian Details

<i>Fatal</i>	Yes
<i>Age</i>	57
<i>Sex</i>	Male
<i>BAC Pedestrian</i>	0 %
<i>Action</i>	Walking
<i>Movement</i>	Following the road
<i>Side Impacted</i>	Back to vehicle

Driver Details

<i>Age</i>	33
<i>Sex</i>	Male
<i>BAC Driver</i>	.14 %
<i>Driving Experience</i>	17 years
<i>Licence Type</i>	Full
<i>Driver Action</i>	No attempt made to avoid collision

Impact Vehicle Details

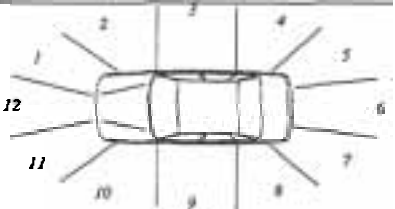
<i>Vehicle Model</i>	1972 Holden	
<i>Type</i>	Car	
<i>Number Involved</i>	1	
<i>Modifications</i>	None	
<i>Impact Point</i>	12	

Road Site Details

<i>Traffic Control of Area</i>	None	<i>Road Type</i>	Arterial
<i>Traffic Conditions</i>	Light	<i>Road Alignment</i>	Straight
<i>Weather Conditions</i>	Fine , dry road	<i>Natural Lighting</i>	Night
<i>Number of Lanes</i>	2	<i>Street Lighting</i>	None
<i>Road Division</i>	Line		

Site Diagram

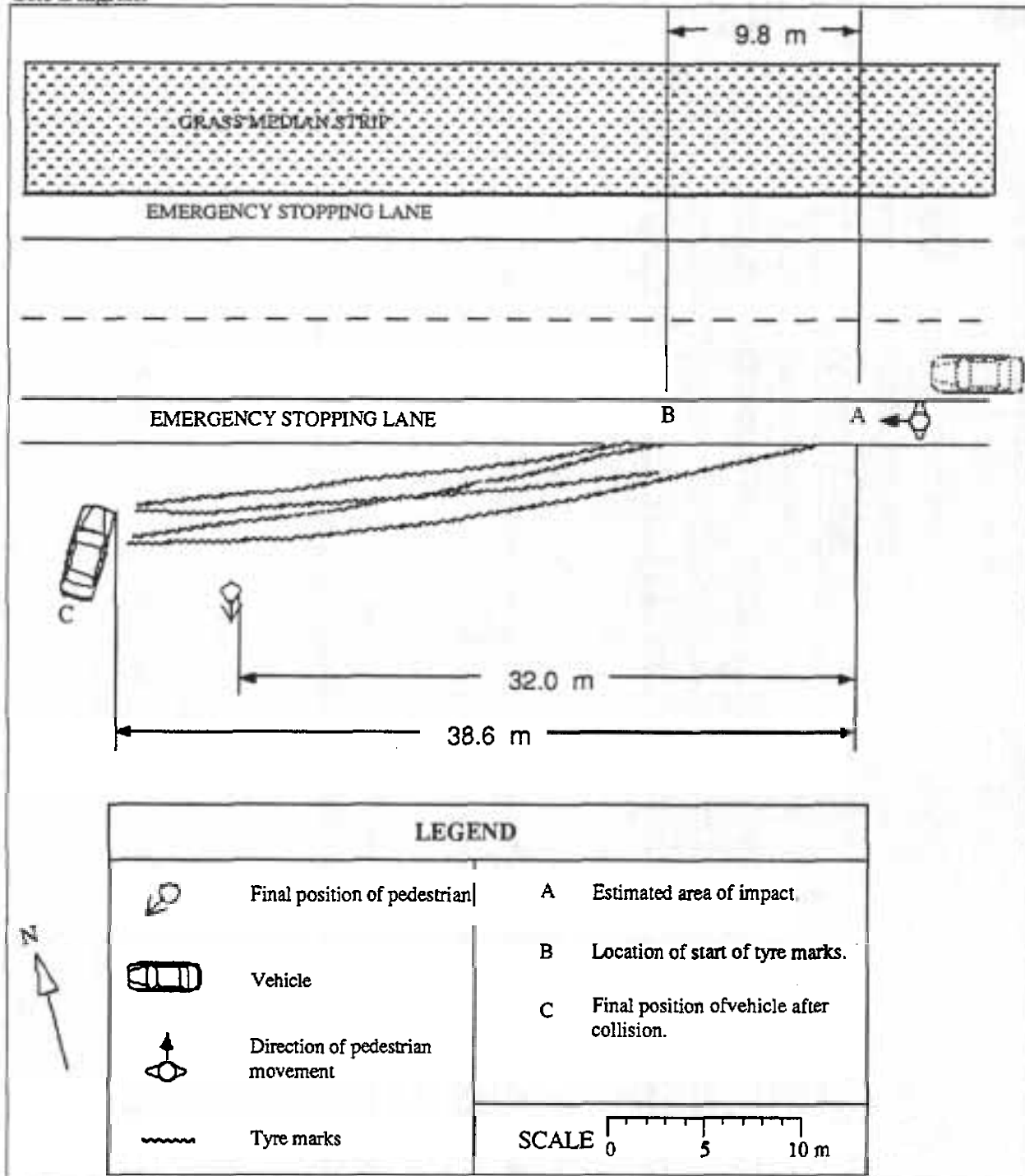

Accident Description

The vehicle was travelling in a north westerly direction. Driver could not recall how the accident occurred or that he had hit a pedestrian. Driver thought that perhaps the vehicle's tyre had blown out or he had fallen asleep. There was no independent witnesses to the accident and there was no evidence at the accident scene to support a point of impact. However, the following assumptions could be made; the pedestrian was walking in a westerly direction along the freeway in the southern most emergency lane and the driver had been travelling at a minimum speed of 69 km/hr. The pedestrian was hit from behind. The events of this case would not be affected directly by the reduction of the travel speed.

Case Details

<i>Case Number</i>	86 - H035	<i>Case type</i>	Insufficient information
<i>Date of Accident</i>	Sunday, May	<i>Time</i>	12 pm
<i>Speed Limit</i>	60 km/hr	<i>Number of Pedestrians Involved</i>	1
<i>Travel Speed</i>	60 km/hr	<i>Travel Speed Source</i>	Driver

Pedestrian Details

<i>Fatal</i>	Yes
<i>Age</i>	82
<i>Sex</i>	Female
<i>BAC Pedestrian</i>	0 %
<i>Action</i>	Walking
<i>Movement</i>	Crossing the road
<i>Side Impacted</i>	Right side to vehicle

Driver Details

<i>Age</i>	24
<i>Sex</i>	Male
<i>BAC Driver</i>	0 %
<i>Driving Experience</i>	6 years
<i>Licence Type</i>	Full
<i>Driver Action</i>	Braked before impact

Impact Vehicle Details

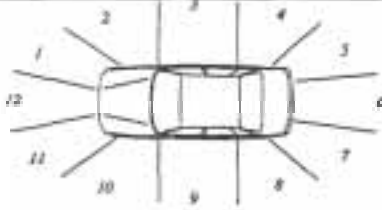
<i>Vehicle Model</i>	1985 Toyota Corona	
<i>Type</i>	Car	
<i>Number Involved</i>	1	
<i>Modifications</i>	None	

Road Site Details

<i>Traffic Control of Area</i>	None	<i>Road Type</i>	Arterial
<i>Traffic Conditions</i>	Heavy	<i>Road Alignment</i>	Straight
<i>Weather Conditions</i>	Fine , dry road	<i>Natural Lighting</i>	Day
<i>Number of Lanes</i>	2	<i>Street Lighting</i>	Not applicable
<i>Road Division</i>	Line		

ite Diagram

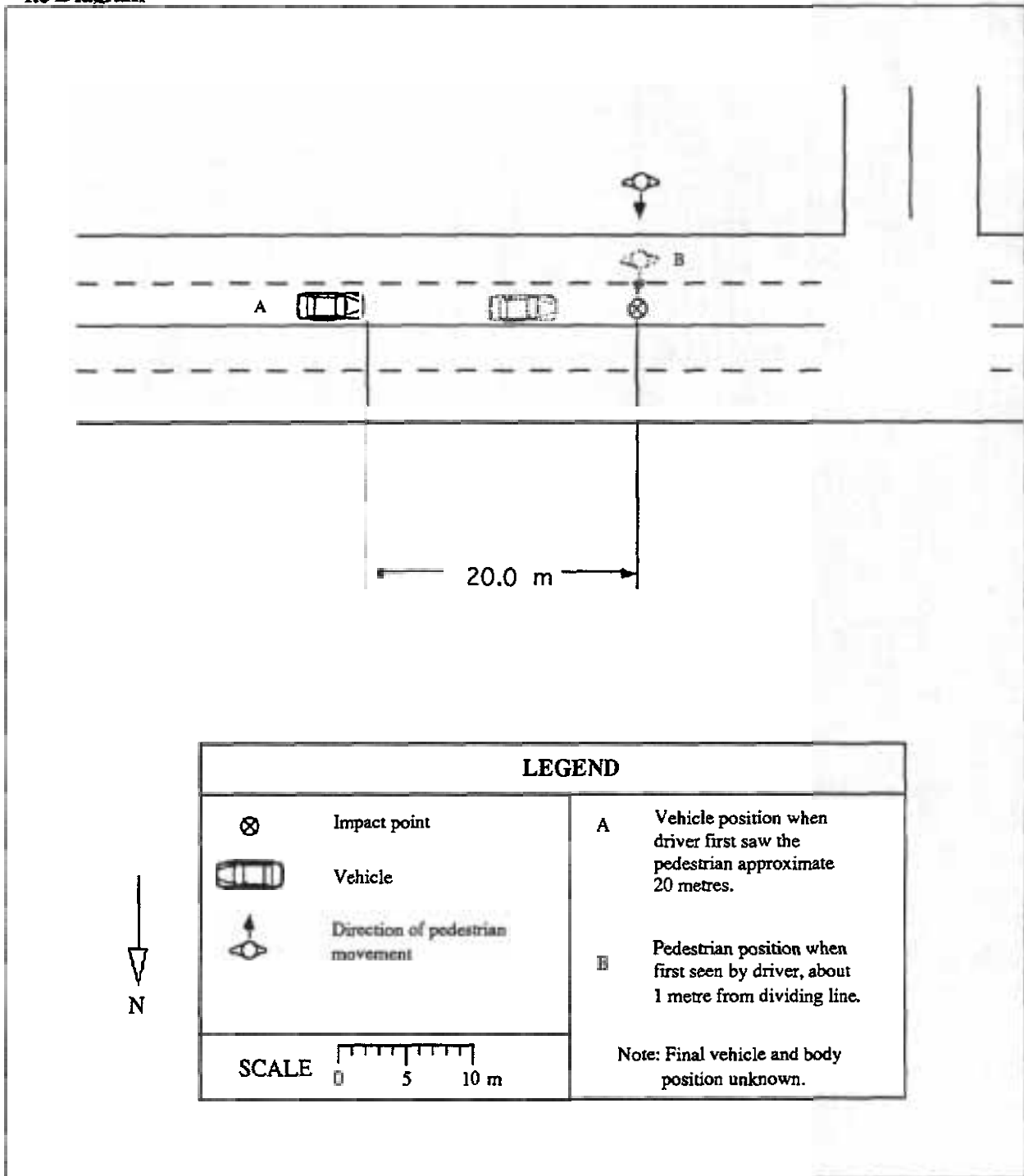

Accident Description

The vehicle was travelling west in the right lane at about 60 km/hr, when the driver saw a pedestrian approximately 20 metres in front of his vehicle. The pedestrian was walking slowly from the south, and was about 1 metre south of the line dividing the two west bound traffic lanes. The driver stated that he took no immediate action on seeing the pedestrian, but as the pedestrian crossed into the lane in which the vehicle was travelling on, the driver applied the brakes, but collided with the pedestrian. The point of impact on the car was on the front right hand side. No skid marks were found at the accident site. Final position of the pedestrian was not recorded.

Case Details

<i>Case Number</i>	86 - H038	<i>Case type</i>	Insufficient information
<i>Date of Accident</i>	Tuesday, June	<i>Time</i>	2 pm
<i>Speed Limit</i>	60 km/hr	<i>Number of Pedestrians Involved</i>	1
<i>Travel Speed</i>	50 km/hr	<i>Travel Speed Source</i>	Driver and witness

<i>Fatal</i>	Yes
<i>Age</i>	77
<i>Sex</i>	Male
<i>BAC Pedestrian</i>	0 %
<i>Action</i>	Walking
<i>Movement</i>	Crossing the road
<i>Side Impacted</i>	Right side to vehicle

<i>Age</i>	24
<i>Sex</i>	Female
<i>BAC Driver</i>	0 %
<i>Driving Experience</i>	8 years
<i>Licence Type</i>	Full
<i>Driver Action</i>	Braked before impact

Impact Vehicle Details

<i>Vehicle Model</i>	1983 Datsun Bluebird	<i>Impact Point</i> 11	
<i>Type</i>	Car		
<i>Number Involved</i>	1		
<i>Modifications</i>	None		

Road Site Details

<i>Traffic Control of Area</i>	None	<i>Road Type</i>	Arterial
<i>Traffic Conditions</i>	Moderate	<i>Road Alignment</i>	Straight
<i>Weather Conditions</i>	Fine , dry road	<i>Natural Lighting</i>	Day
<i>Number of Lanes</i>	2	<i>Street Lighting</i>	Not applicable
<i>Road Division</i>	Raised median strip		

Site Diagram

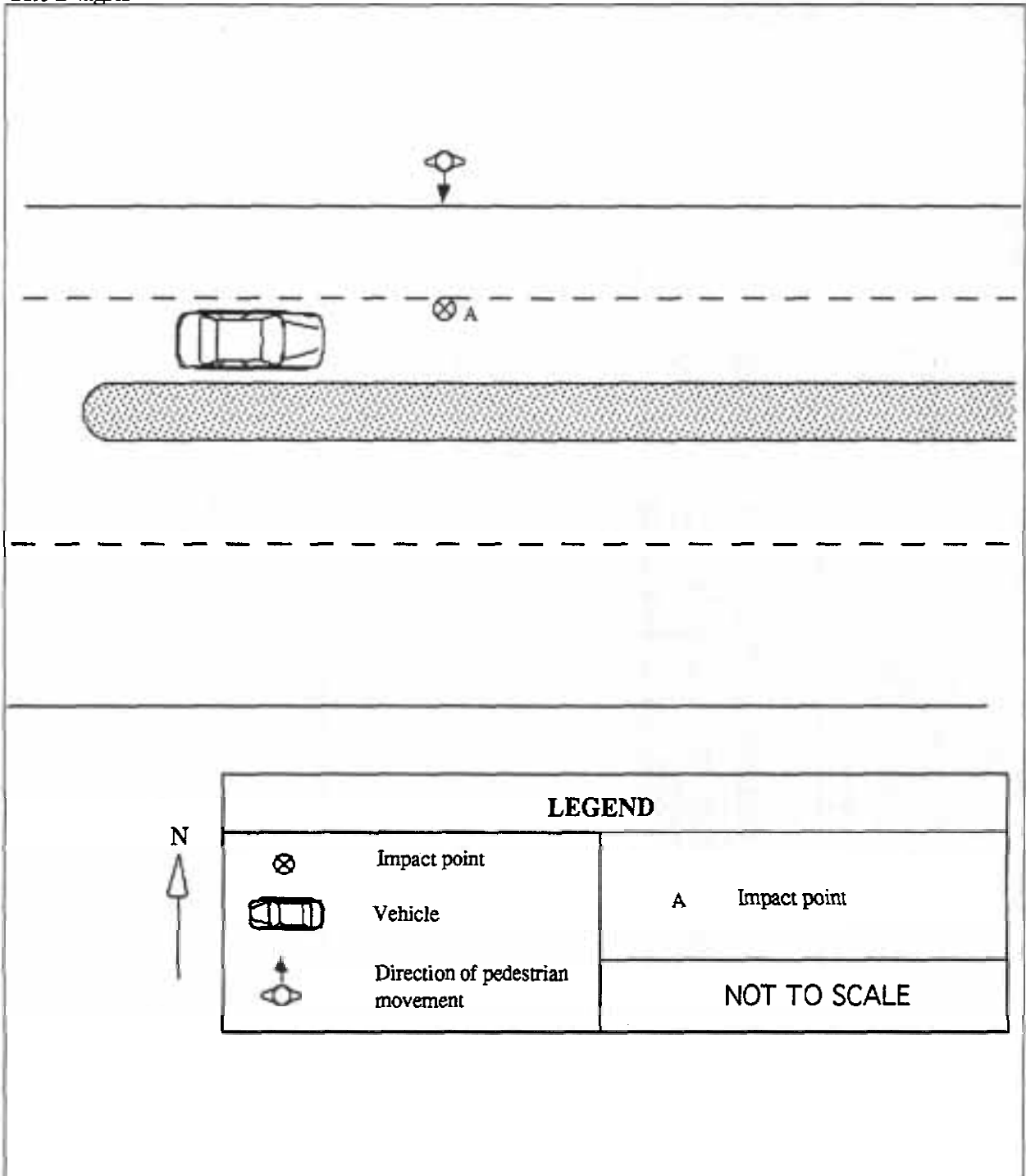

Accident Description

The pedestrian walked from a bus stop on the northern side of the road in a southerly direction in front of east bound traffic. A vehicle travelling in the northern most lane braked slightly to avoid a collision and then passed to the rear of the pedestrian. The case vehicle was travelling east in the right lane at a speed estimated by the driver to be 50 km/hr and accelerating slightly, she saw the pedestrian, braked hard and collided with the pedestrian.

Case Details

<i>Case Number</i>	86 - H039	<i>Case type</i>	Off road
<i>Date of Accident</i>	Wednesday, June	<i>Time</i>	11 am
<i>Speed Limit</i>	10 km/hr	<i>Number of Pedestrians Involved</i>	1
<i>Travel Speed</i>	Unknown km/hr	<i>Travel Speed Source</i>	Unknown

Pedestrian Details

<i>Fatal</i>	Yes
<i>Age</i>	2
<i>Sex</i>	Male
<i>BAC Pedestrian</i>	0%
<i>Action</i>	Standing
<i>Movement</i>	Other
<i>Side Impacted</i>	Facing vehicle

Driver Details

<i>Age</i>	74
<i>Sex</i>	Female
<i>BAC Driver</i>	0%
<i>Driving Experience</i>	25 years
<i>Licence Type</i>	Full
<i>Driver Action</i>	No attempt made to avoid collision

Impact Vehicle Details

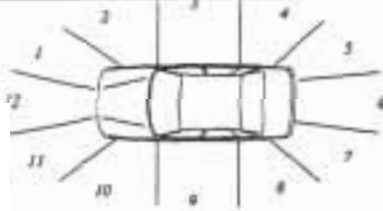
<i>Vehicle Model</i>	1974 Honda Civic	
<i>Type</i>	Car	
<i>Number Involved</i>	1	
<i>Modifications</i>	None	
<i>Impact Point</i>	1	

Road Site Details

<i>Traffic Control of Area</i>	None	<i>Road Type</i>	Car park
<i>Traffic Conditions</i>	Not applicable	<i>Road Alignment</i>	Not applicable
<i>Weather Conditions</i>	Unknown	<i>Natural Lighting</i>	Day
<i>Number of Lanes</i>	Not Applicable	<i>Street Lighting</i>	Not applicable
<i>Road Division</i>	Unknown		

Site Diagram

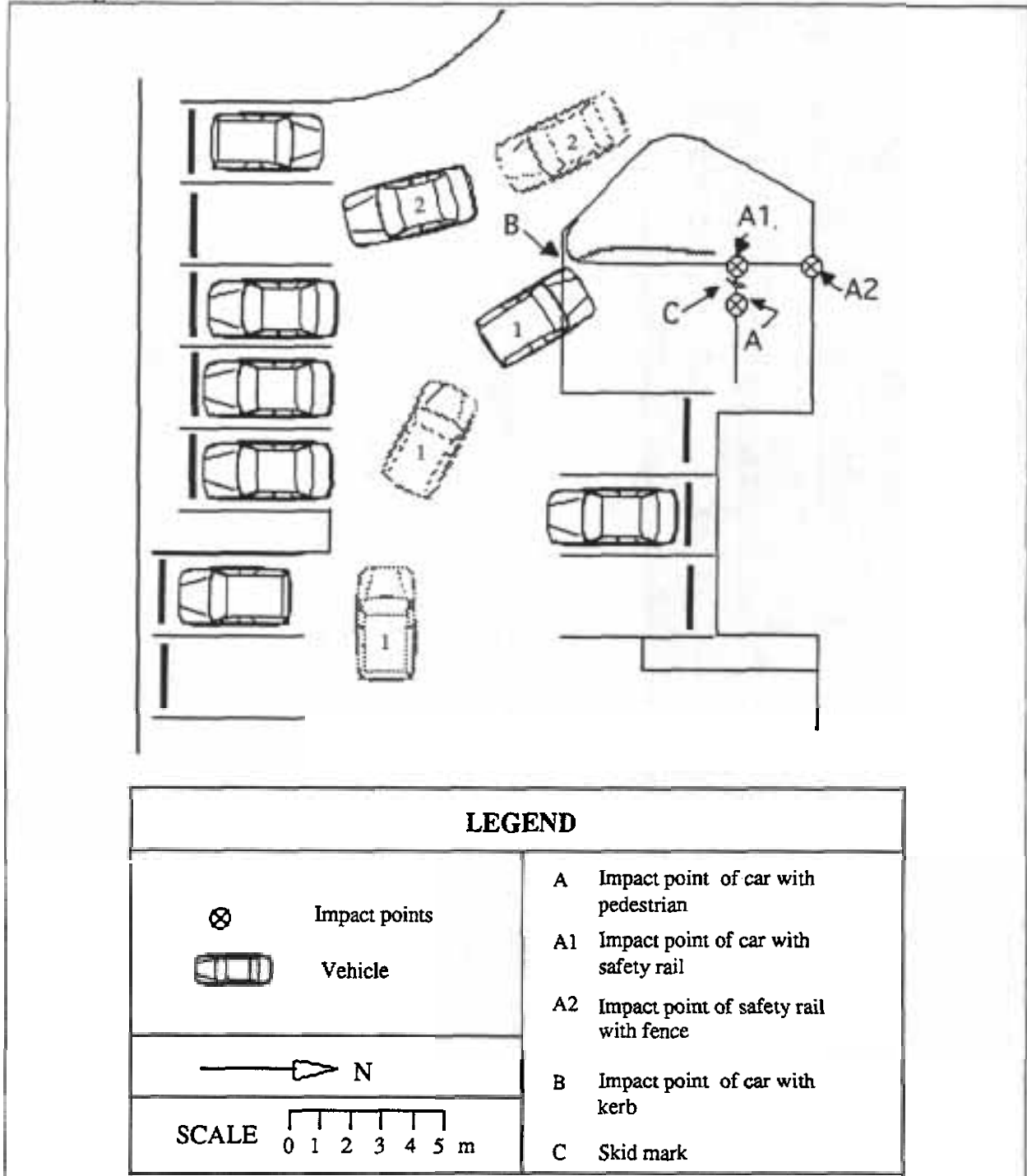

Accident Description

Vehicle 1 was travelling in a westerly direction at an assumed speed of 5 km/hr in the confines of a car park. Vehicle 2 was moving into a parking space near the car park entrance and was blocking the entrance. For no apparent reason vehicle 1 suddenly accelerated rapidly and swerved sharply to the right. The left side wheels mounted the traffic island at point B and then collided with a child standing in front of a safety rail at point A and continued forward colliding with the safety rail at A1, which impacted the fence at point A2. The car stopped and then reversed back over the child. The driver of the vehicle 1 cannot remember the events clearly and at the time was suffering from an illness that could cause mental disturbances. This case was rejected because these events would not be affected directly by reducing the travel speed.

Case Details

<i>Case Number</i>	86 - H065	<i>Case type</i>	Manoeuvre
<i>Date of Accident</i>	Wednesday, September	<i>Time</i>	6 pm
<i>Speed Limit</i>	60 km/hr	<i>Number of Pedestrians Involved</i>	2
<i>Travel Speed</i>	Unknown km/hr	<i>Travel Speed Source</i>	Unknown

Pedestrian 1 Details

<i>Fatal</i>	Yes
<i>Age</i>	Unknown
<i>Sex</i>	Male
<i>BAC Pedestrian</i>	Unknown %
<i>Action</i>	Standing
<i>Movement</i>	None
<i>Side Impacted</i>	Unknown

Pedestrian 2 Details

<i>Fatal</i>	Yes
<i>Age</i>	Unknown
<i>Sex</i>	Male
<i>BAC Pedestrian</i>	Unknown %
<i>Action</i>	Standing
<i>Movement</i>	None
<i>Side Impacted</i>	Unknown

Driver Details

<i>Age</i>	Unknown	<i>Driving Experience</i>	Unknown years	<i>Driver Action</i>	Unknown
<i>Sex</i>	Unknown	<i>Licence Type</i>	Unknown		
		<i>BAC Driver</i>	Unknown %		

Impact Vehicle Details

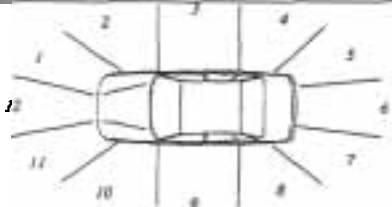
<i>Vehicle Model</i>	Holden Belmont	<i>Impact Point</i> 12	
<i>Type</i>	Car		
<i>Number Involved</i>	1		
<i>Modifications</i>	Unknown		

Road Site Details

<i>Traffic Control of Area</i>	None	<i>Road Type</i>	Arterial
<i>Traffic Conditions</i>	Unknown	<i>Road Alignment</i>	Straight
<i>Weather Conditions</i>	Unknown	<i>Natural Lighting</i>	Dusk
<i>Number of Lanes</i>		<i>Street Lighting</i>	Unknown
<i>Road Division</i>			

Site Diagram

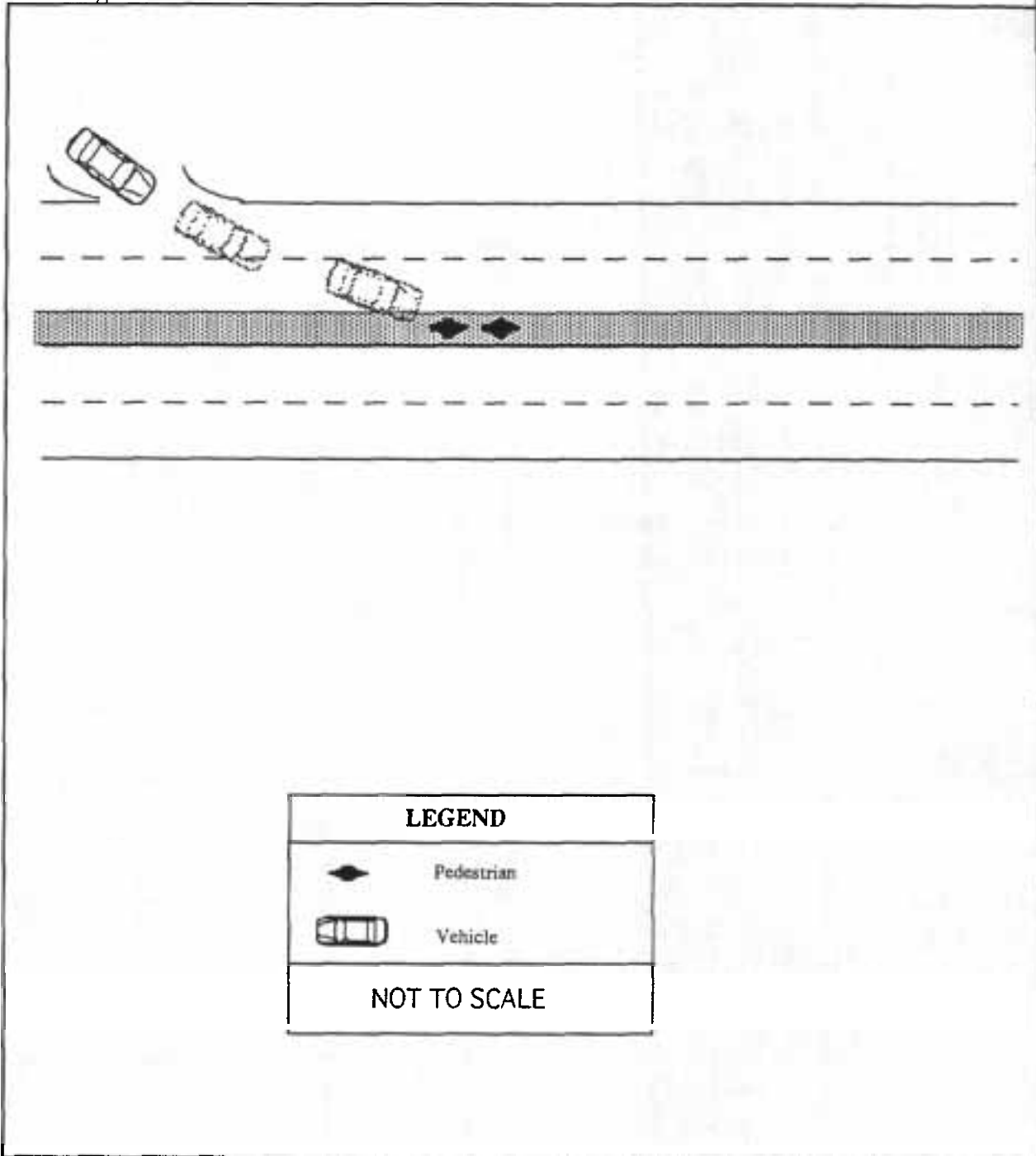

Accident Description

Two pedestrians were standing on median strip selling newspapers. The case vehicle turned left at high speed, swung wide and mounted the median strip, colliding with the pedestrians. Both pedestrians was killed. No other information was available.

Case Details

<i>Case Number</i>	86 - H067	<i>Case type</i>	Manoeuvre
<i>Date of Accident</i>	Friday, September	<i>Time</i>	9 pm
<i>Speed Limit</i>	60 km/hr	<i>Number of Pedestrians Involved</i>	1
<i>Travel Speed</i>	10 km/hr	<i>Travel Speed Source</i>	Police

Pedestrian Details

<i>Fatal</i>	Yes
<i>Age</i>	71
<i>Sex</i>	Male
<i>BAC Pedestrian</i>	.032 %
<i>Action</i>	Walking
<i>Movement</i>	Crossing the road
<i>Side Impacted</i>	Left side to vehicle

Driver Details

<i>Age</i>	33
<i>Sex</i>	Male
<i>BAC Driver</i>	0 %
<i>Driving Experience</i>	4 years
<i>Licence Type</i>	Full
<i>Driver Action</i>	Braked before impact

Impact Vehicle Details

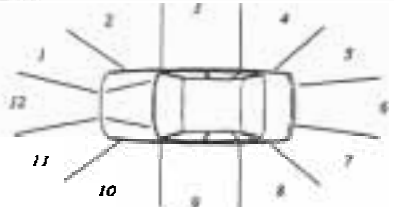
<i>Vehicle Model</i>	1981 Mitsubishi Sigma	
<i>Type</i>		
<i>Number Involved</i>	1	
<i>Modifications</i>	None	

Road Site Details

<i>Traffic Control of Area</i>	Traffic signal at intersection	<i>Road Type</i>	Arterial
<i>Traffic Conditions</i>	Light	<i>Road Alignment</i>	Not applicable
<i>Weather Conditions</i>	Fine , dry road	<i>Natural Lighting</i>	Night
<i>Number of Lanes</i>	2	<i>Street Lighting</i>	Street lights
<i>Road Division</i>	Line		

Site Diagram

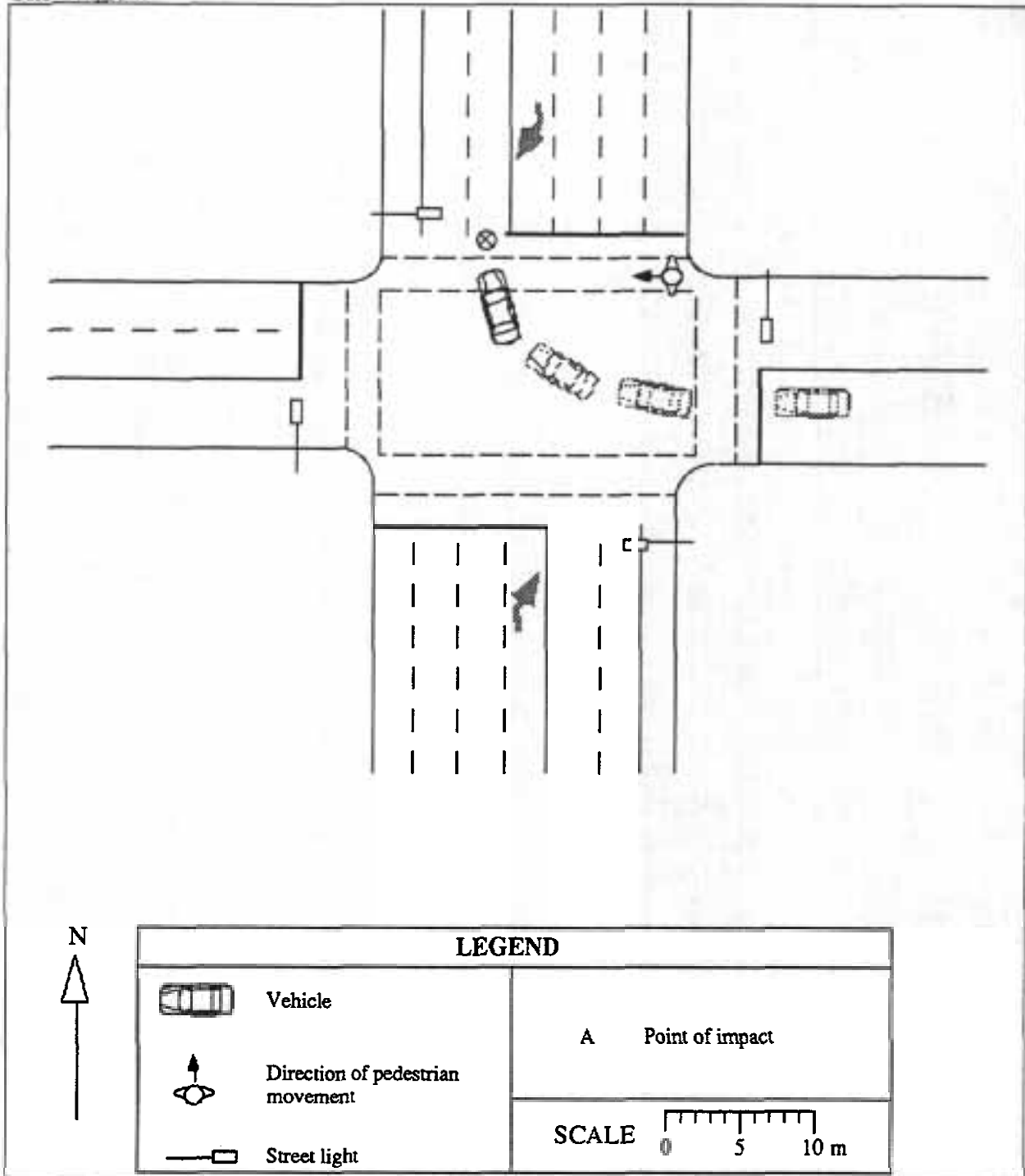

Accident Description

The case vehicle was travelling in a westerly direction and was intending to turn right at the intersection to travel north. The driver moved into the intersection and waited for the on coming traffic to pass, and by this stage the lights had changed to amber. He accelerated in a normal manner to about 10 km/hr and had nearly completed his turn when he collided with the pedestrian at point A. The right front of the bonnet struck the left side of the pedestrian and the driver braked immediately with the pedestrian rolling off the left side of the bonnet.

Case Details

<i>Case Number</i>	86 - H079	<i>Case type</i>	Insufficient information
<i>Date of Accident</i>	Monday, November	<i>Time</i>	5 am
<i>Speed Limit</i>	60 km/hr	<i>Number of Pedestrians Involved</i>	1
<i>Travel Speed</i>	55 km/hr	<i>Travel Speed Source</i>	Driver

Pedestrian Details

<i>Fatal</i>	Yes
<i>Age</i>	61
<i>Sex</i>	Male
<i>BAC Pedestrian</i>	0%
<i>Action</i>	Walking
<i>Movement</i>	Crossing the road
<i>Side Impacted</i>	Left side to vehicle

Driver Details

<i>Age</i>	Unknown
<i>Sex</i>	Unknown
<i>BAC Driver</i>	0%
<i>Driving Experience</i>	Unknown years
<i>Licence Type</i>	Unknown
<i>Driver Action</i>	Braked before impact

Impact Vehicle Details

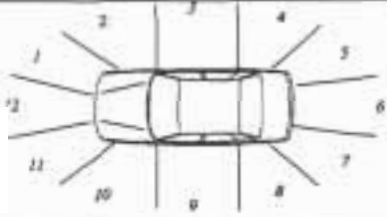
<i>Vehicle Model</i>	1970 Toyota Corona	
<i>Type</i>	Car	
<i>Number Involved</i>	1	
<i>Modifications</i>	None	
<i>Impact Point</i>	11	

Road Site Details

<i>Traffic Control of Area</i>	Traffic signal at intersection	<i>Road Type</i>	Arterial
<i>Traffic Conditions</i>	Light	<i>Road Alignment</i>	Straight
<i>Weather Conditions</i>	Fine, dry road	<i>Natural Lighting</i>	Dawn
<i>Number of Lanes</i>	2	<i>Street Lighting</i>	Street lights
<i>Road Division</i>	Raised median strip		

Site Diagram

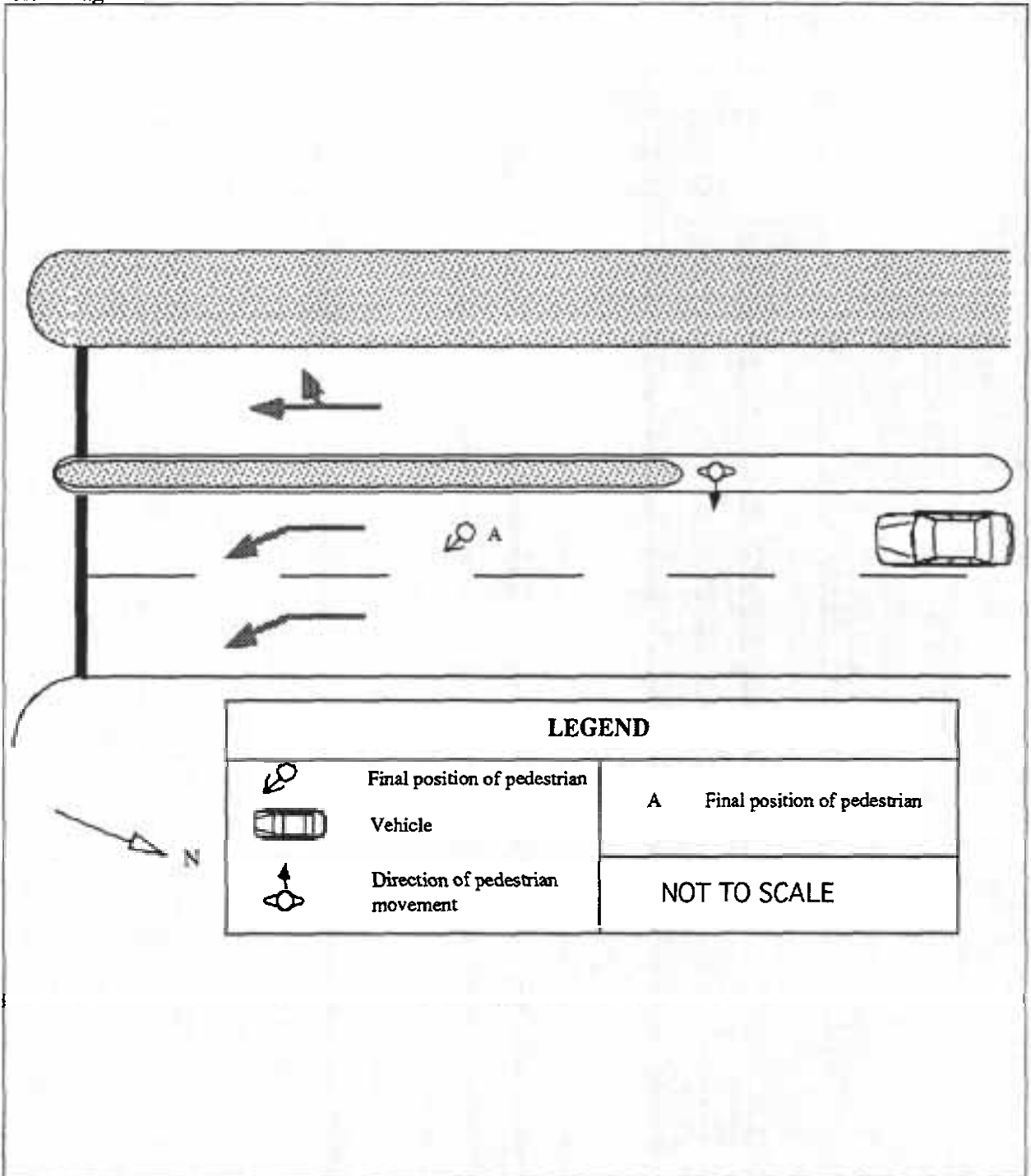

Accident Description

The case vehicle was travelling south at about 60 km/hr when the driver saw the pedestrian standing on the raised median strip. The pedestrian then took two steps into the path of the vehicle. The driver braked hard but a collision occurred. The driver then took the pedestrian to hospital.

Case Details

<i>Case Number</i>	87 - H016	<i>Case type</i>	Driver unconscious
<i>Date of Accident</i>	Thursday, March	<i>Time</i>	7 am
<i>Speed Limit</i>	60 km/hr	<i>Number of Pedestrians Involved</i>	2
<i>Travel Speed</i>	50 km/hr	<i>Travel Speed Source</i>	Driver and witness

Pedestrian 1 Details

<i>Fatal</i>	Yes
<i>Age</i>	39
<i>Sex</i>	Male
<i>BAC Pedestrian</i>	0 %
<i>Action</i>	Standing
<i>Movement</i>	Crossing the road
<i>Side Impacted</i>	Left side to vehicle

Pedestrian 2 Details

<i>Fatal</i>	Yes
<i>Age</i>	Unknown
<i>Sex</i>	Unknown
<i>BAC Pedestrian</i>	Unknown %
<i>Action</i>	Standing
<i>Movement</i>	Crossing the road
<i>Side Impacted</i>	Unknown

Driver Details

<i>Age</i>	20	<i>Driving Experience</i>	3 years	<i>Driver Action</i>	No attempt made to avoid collision
<i>Sex</i>	Male	<i>Licence Type</i>	Full		
		<i>BAC Driver</i>	.105 %		

Impact Vehicle Details

<i>Vehicle Model</i>	Holden Commodore	<i>Impact Point</i>	12
<i>Type</i>	Car		
<i>Number Involved</i>	1		
<i>Modifications</i>	None		

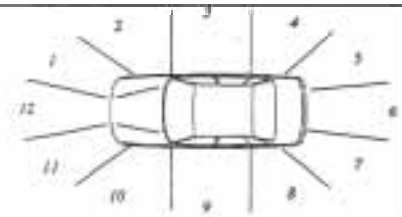

Road Site Details

<i>Traffic Control of Area</i>	None	<i>Road Type</i>	Arterial
<i>Traffic Conditions</i>	Moderate	<i>Road Alignment</i>	Straight
<i>Weather Conditions</i>	Fine , dry road	<i>Natural Lighting</i>	Dawn
<i>Number of Lanes</i>	3	<i>Street Lighting</i>	Street lights
<i>Road Division</i>	Raised median strip		

Site Diagram

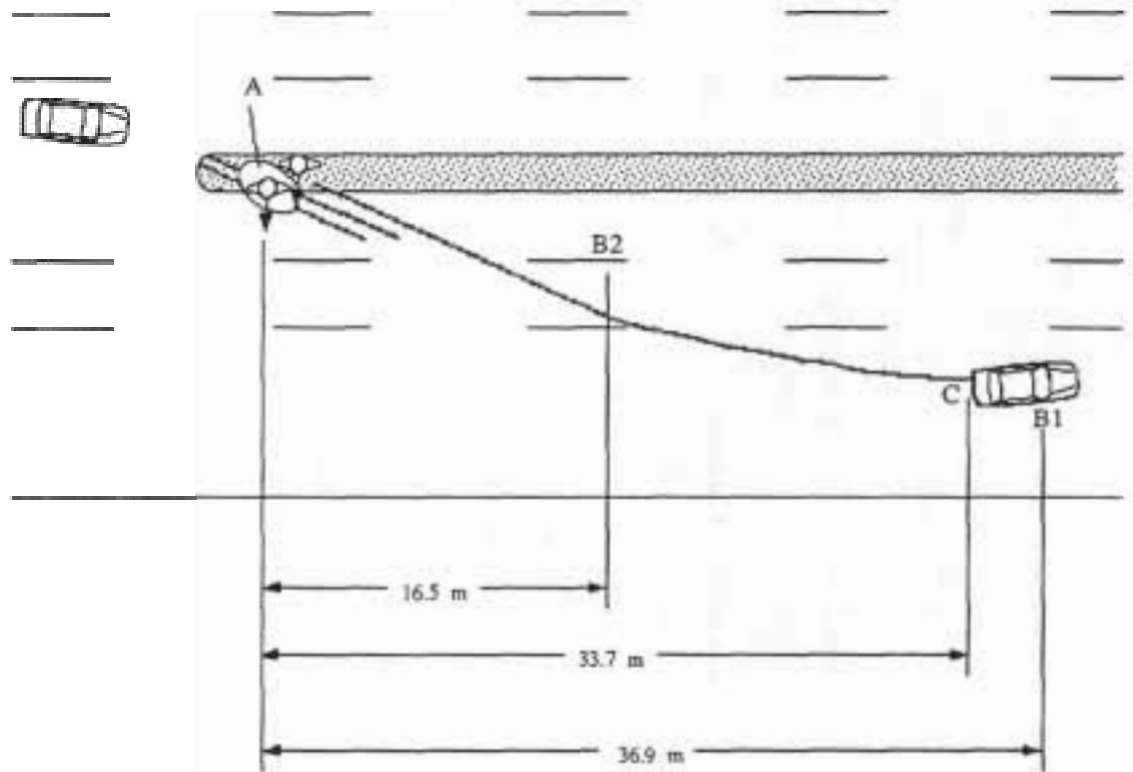

LEGEND	
	Vehicle
	Direction of pedestrian movement
	Tyre marks
	Impact area
	N
SCALE 0 5 10 m	
A	Impact area
B1	Final position of Pedestrian 1
B2	Final position of Pedestrian 2
C	Final position of vehicle

Accident Description

The car was travelling in an easterly direction at 60 km/hr. The driver claims that he fell asleep at the wheel and was waken up by the impact. Two pedestrians were standing on the raised median strip facing north when the car veered right and collided with them in the area A. Pedestrian 1 rolled onto the left side of the bonnet and was carried on the bonnet of the car falling to the roadway at point B1. Pedestrian 2 rolled onto the right side of the bonnet impacting the plenum chamber and the A pillar then went over the roof coming to rest at point B2. Both the pedestrians received fatal injuries. The car stopped at point C.

Case Details

<i>Case Number</i>	87 - H018	<i>Case type</i>	Off road
<i>Date of Accident</i>	Tuesday, March	<i>Time</i>	5 pm
<i>Speed Limit</i>	60 km/hr	<i>Number of Pedestrians Involved</i>	1
<i>Travel Speed</i>	100 km/hr	<i>Travel Speed Source</i>	Witness

Pedestrian Details

<i>Fatal</i>	Yes
<i>Age</i>	61
<i>Sex</i>	Male
<i>BAC Pedestrian</i>	0 %
<i>Action</i>	Other
<i>Movement</i>	Other
<i>Side Impacted</i>	Facing vehicle

Driver Details

<i>Age</i>	21
<i>Sex</i>	Male
<i>BAC Driver</i>	.15 %
<i>Driving Experience</i>	3 years
<i>Licence Type</i>	Full
<i>Driver Action</i>	No attempt made to avoid collision

Impact Vehicle Details

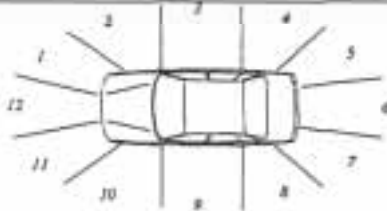
<i>Vehicle Model</i>	Holden Commodore	
<i>Type</i>	Car	
<i>Number Involved</i>	1	
<i>Modifications</i>	None	
<i>Impact Point</i>	10	

Road Site Details

<i>Traffic Control of Area</i>	None	<i>Road Type</i>	Local street
<i>Traffic Conditions</i>	Moderate	<i>Road Alignment</i>	Not applicable
<i>Weather Conditions</i>	Unknown	<i>Natural Lighting</i>	Day
<i>Number of Lanes</i>	1	<i>Street Lighting</i>	None
<i>Road Division</i>	Line		

ite Diagram

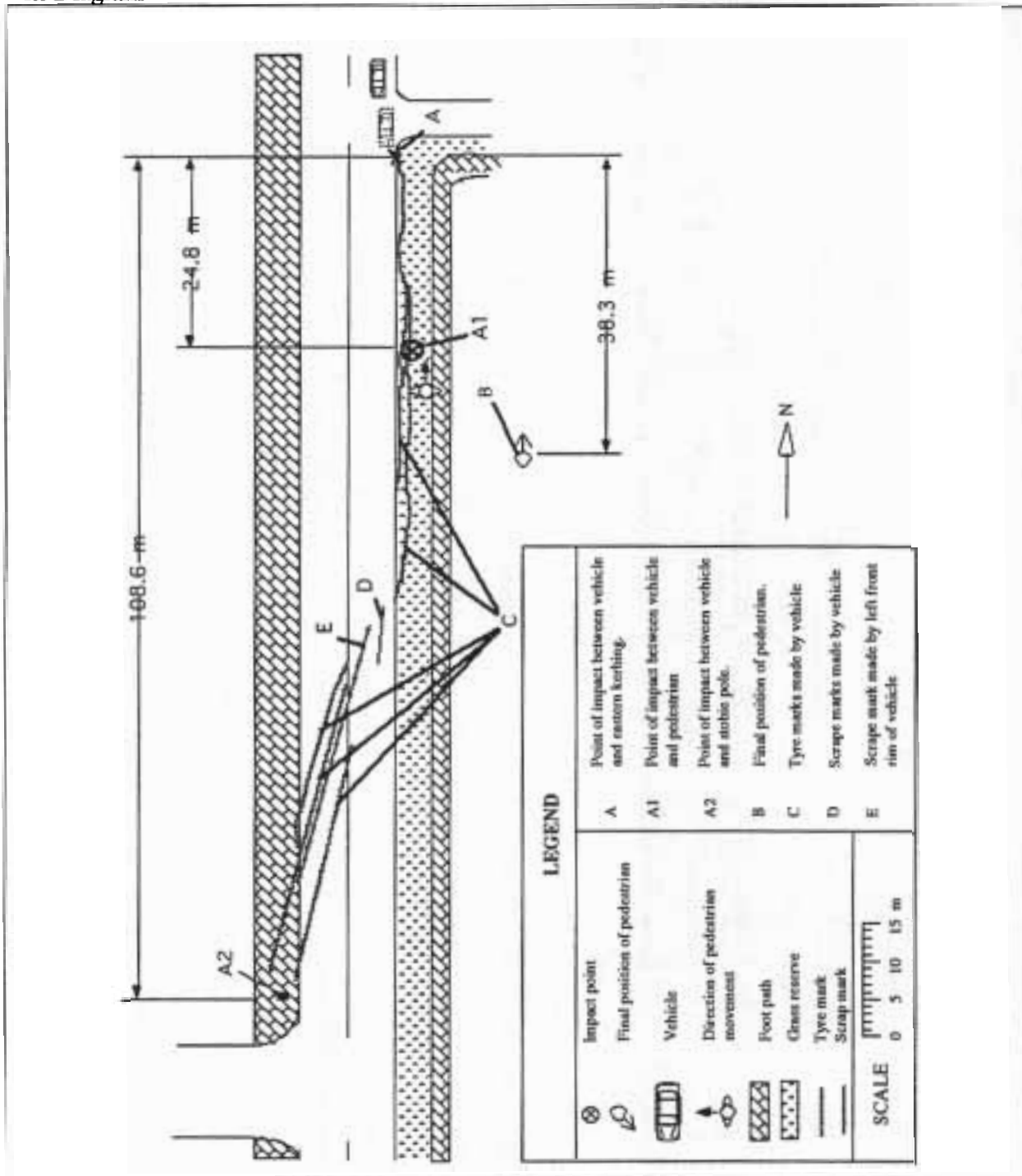

Accident Description

The driver stated that while travelling in a southerly direction he lost control of the vehicle as another vehicle made a left hand turn in front of him. However the presence of this other vehicle was not corroborated by witnesses. The vehicle collided with a kerbing and slid sideways along the footpath area before colliding with a pedestrian. With the vehicle out of control, the vehicle slid across to the opposite of the roadway and rolled sideways into a utility pole. Independent witnesses to the accident estimate the vehicle was travelling at 80 to 110 km/hr. The pedestrians was hit front on by the left hand side of the vehicle.

Case Details

<i>Case Number</i>	87 - H030	<i>Case type</i>	Manoeuvre
<i>Date of Accident</i>	Friday, June	<i>Time</i>	10 am
<i>Speed Limit</i>	60 km/hr	<i>Number of Pedestrians Involved</i>	1
<i>Travel Speed</i>	45 km/hr	<i>Travel Speed Source</i>	Driver

<i>Fatal</i>	Yes
<i>Age</i>	75
<i>Sex</i>	Male
<i>BAC Pedestrian</i>	0 %
<i>Action</i>	Running
<i>Movement</i>	Crossing the road
<i>Side Impacted</i>	Left side to vehicle

<i>Age</i>	31
<i>Sex</i>	Male
<i>BAC Driver</i>	0 %
<i>Driving Experience</i>	15 years
<i>Licence Type</i>	Full
<i>Driver Action</i>	Braked before impact

Impact Vehicle Details

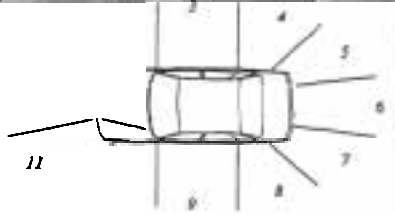
<i>Vehicle Model</i>	1986 Ford Falcon	
<i>Type</i>	Car	
<i>Number Involved</i>	1	
<i>Modifications</i>	None	

Road Site Details

<i>Traffic Control of Area</i>	Traffic signal at intersection	<i>Road Type</i>	Arterial
<i>Traffic Conditions</i>	Moderate	<i>Road Alignment</i>	Straight
<i>Weather Conditions</i>	Fine , dry road	<i>Natural Lighting</i>	Day
<i>Number of Lanes</i>	4	<i>Street Lighting</i>	Not applicable
<i>Road Division</i>	Raised median strip		

Site Diagram

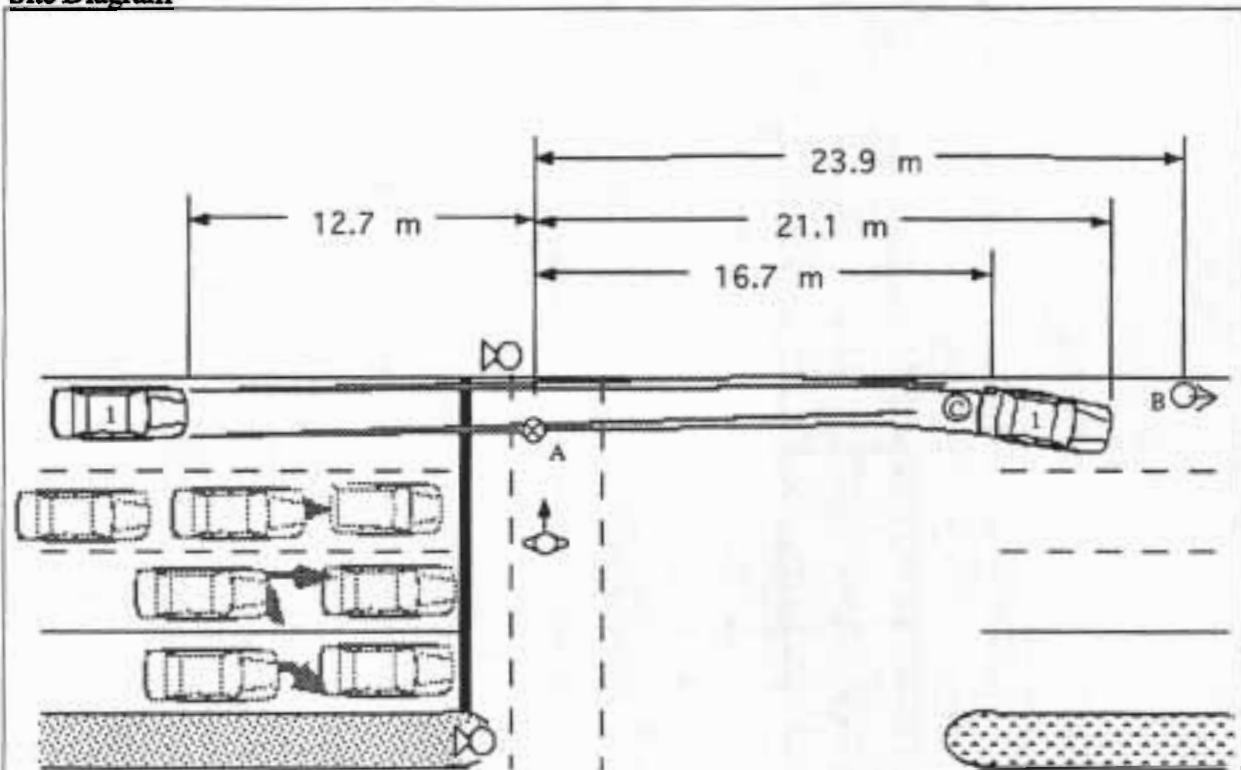

ONLY EASTBOUND TRAFFIC SHOWN

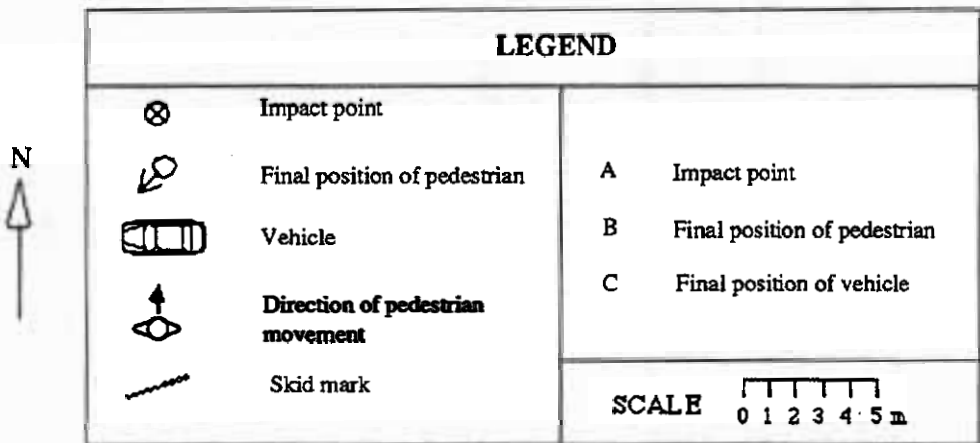

Accident Description

Vehicle 1 was travelling in an easterly direction in the left lane. The driver was approaching the traffic signals which were red and had slowed his vehicle down to about 20 km/hr. When he was about 25 metres from the junction, they turned green and he began to accelerate to about 45km/hr. When he was about 12 metres away from the stopping line he saw a pedestrian crossing in a northerly direction and applied the brakes. The pedestrian was crossing the road from the southern kerb against the red pedestrian lights. The traffic in the centre lanes had not moved off as this pedestrian was walking in front of them. He continued in a northerly direction straight into the path of vehicle 1. An impact occurred at point A. The pedestrian was hit on his left hand side by the front right corner of the bonnet, rolled onto the bonnet and was carried along until the car stopped at point C when the pedestrian rolled off and came to rest at point B.

Case Details

<i>Case Number</i>	87 - H047	<i>Case type</i>	Insufficient information
<i>Date of Accident</i>	Wednesday, October	<i>Time</i>	4 pm
<i>Speed Limit</i>	60 km/hr	<i>Number of Pedestrians Involved</i>	2
<i>Travel Speed</i>	Unknown km/hr	<i>Travel Speed Source</i>	Unknown

Pedestrian 1 Details

<i>Fatal</i>	Yes
<i>Age</i>	Unknown
<i>Sex</i>	Female
<i>BAC Pedestrian</i>	Unknown %
<i>Action</i>	Unknown
<i>Movement</i>	Unknown
<i>Side Impacted</i>	Unknown

Pedestrian 2 Details

<i>Fatal</i>	Yes
<i>Age</i>	Unknown
<i>Sex</i>	Male
<i>BAC Pedestrian</i>	Unknown %
<i>Action</i>	Unknown
<i>Movement</i>	Unknown
<i>Side Impacted</i>	Unknown

Driver Details

<i>Age</i>	Unknown	<i>Driving Experience</i>	Unknown years	<i>Driver Action</i>	Unknown
<i>Sex</i>	Unknown	<i>Licence Type</i>	Unknown		
		<i>BAC Driver</i>	Unknown %		

Impact Vehicle Details

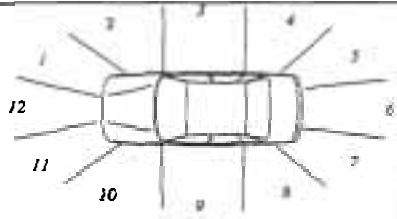
<i>Vehicle Model</i>	Unknown	<i>Impact Point</i>	
<i>Type</i>	Car		
<i>Number Involved</i>	1		
<i>Modifications</i>	Unknown		

Road Site Details

<i>Traffic Control of Area</i>	None	<i>Road Type</i>	Arterial
<i>Traffic Conditions</i>	Unknown	<i>Road Alignment</i>	Straight
<i>Weather Conditions</i>	Fine , dry road	<i>Natural Lighting</i>	Day
<i>Number of Lanes</i>	3	<i>Street Lighting</i>	Not applicable
<i>Road Division</i>	Raised median strip		

Site Diagram

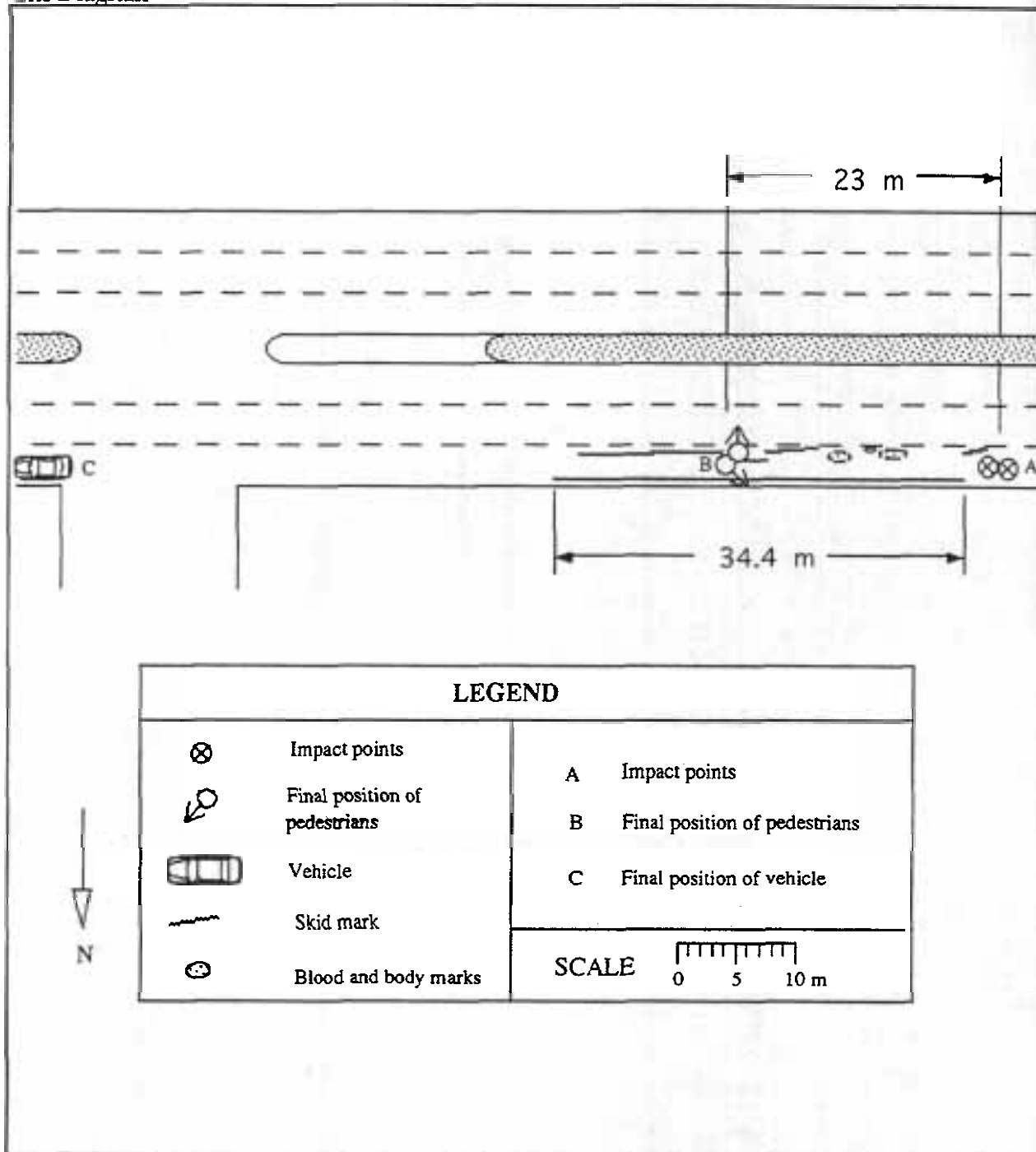

Accident Description

The two pedestrians were fatally injured. Apart from the information above there was no description of how the accident happened. The travel and impact speeds could not be estimated with confidence because the vehicle did not stop at the end of the skid marks and no driver or witness statements were available.

Case Details

<i>Case Number</i>	87 - H048	<i>Case type</i>	Manoeuvre
<i>Date of Accident</i>	Monday, October	<i>Time</i>	3 pm
<i>Speed Limit</i>	60 km/hr	<i>Number of Pedestrians Involved</i>	1
<i>Travel Speed</i>	35 km/hr	<i>Travel Speed Source</i>	Driver

Pedestrian Details

<i>Fatal</i>	Yes
<i>Age</i>	85
<i>Sex</i>	Female
<i>BAC Pedestrian</i>	0 %
<i>Action</i>	Walking
<i>Movement</i>	Crossing the road
<i>Side Impacted</i>	Right side to vehicle

Driver Details

<i>Age</i>	Unknown
<i>Sex</i>	Unknown
<i>BAC Driver</i>	0 %
<i>Driving Experience</i>	Unknown years
<i>Licence Type</i>	Unknown
<i>Driver Action</i>	Braked before impact

Impact Vehicle Details

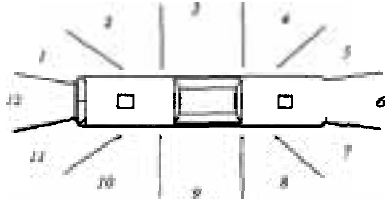
<i>Vehicle Model</i>	1980 Volvo Bus	
<i>Type</i>	Bus	
<i>Number Involved</i>	1	
<i>Modifications</i>	None	
<i>Impact Point</i>	11	

Road Site Details

<i>Traffic Control of Area</i>	None	<i>Road Type</i>	Arterial
<i>Traffic Conditions</i>	Light	<i>Road Alignment</i>	Straight
<i>Weather Conditions</i>	Fine , dry road	<i>Natural Lighting</i>	Day
<i>Number of Lanes</i>	2	<i>Street Lighting</i>	Not applicable
<i>Road Division</i>	Raised median strip		

Site Diagram

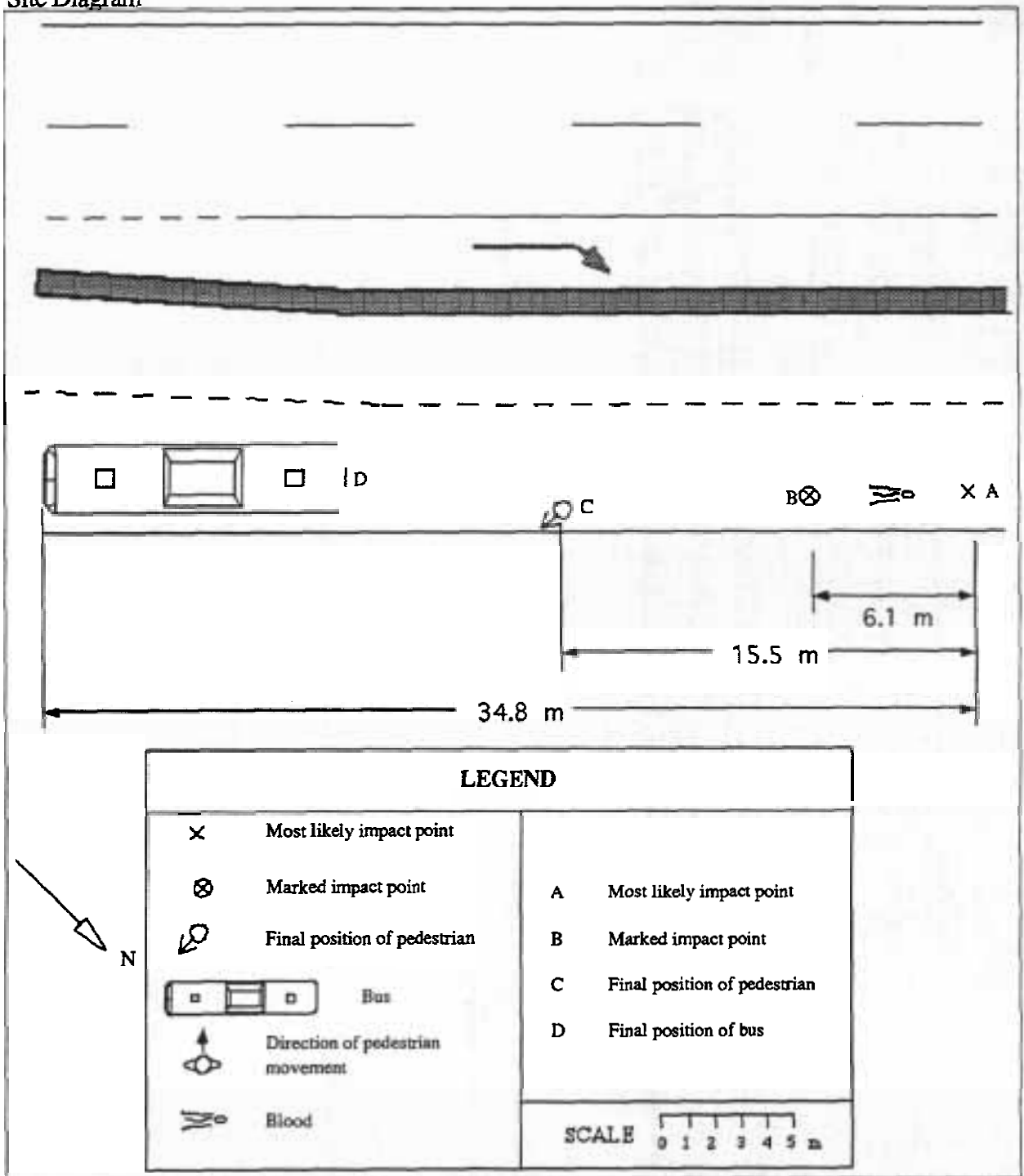

Accident Description

A bus was braking slowly from 35 km/hr as it was approaching a bus stop. A pedestrian stepped in front of the bus when it was 2 metres away. The driver swerved right and braked hard, but a collision occurred at point A.

Case Details

<i>Case Number</i>	87 - H054	<i>Case type</i>	Insufficient information
<i>Date of Accident</i>	Wednesday, November	<i>Time</i>	3 am
<i>Speed Limit</i>	60 km/hr	<i>Number of Pedestrians Involved</i>	1
<i>Travel Speed</i>	50 km/hr	<i>Travel Speed Source</i>	Driver

Pedestrian Details

<i>Fatal</i>	Yes
<i>Age</i>	7
<i>Sex</i>	Female
<i>BAC Pedestrian</i>	0%
<i>Action</i>	Running
<i>Movement</i>	Crossing the road
<i>Side Impacted</i>	Right side to vehicle

Driver Details

<i>Age</i>	33
<i>Sex</i>	Male
<i>BAC Driver</i>	0%
<i>Driving Experience</i>	7 years
<i>Licence Type</i>	Full
<i>Driver Action</i>	Brake after impact

Impact Vehicle Details

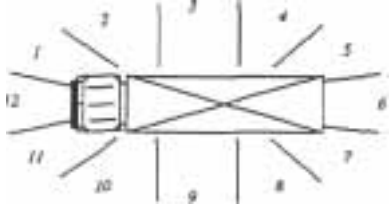
<i>Vehicle Model</i>	Unknown	<i>Impact Point</i> 12 
<i>Type</i>	Truck	
<i>Number Involved</i>	1	
<i>Modifications</i>	None	

Road Site Details

<i>Traffic Control of Area</i>	None	<i>Road Type</i>	Arterial
<i>Traffic Conditions</i>	Heavy	<i>Road Alignment</i>	Straight
<i>Weather Conditions</i>	Fine , dry road	<i>Natural Lighting</i>	Day
<i>Number of Lanes</i>	1	<i>Street Lighting</i>	Not applicable
<i>Road Division</i>	Line		

Site Diagram

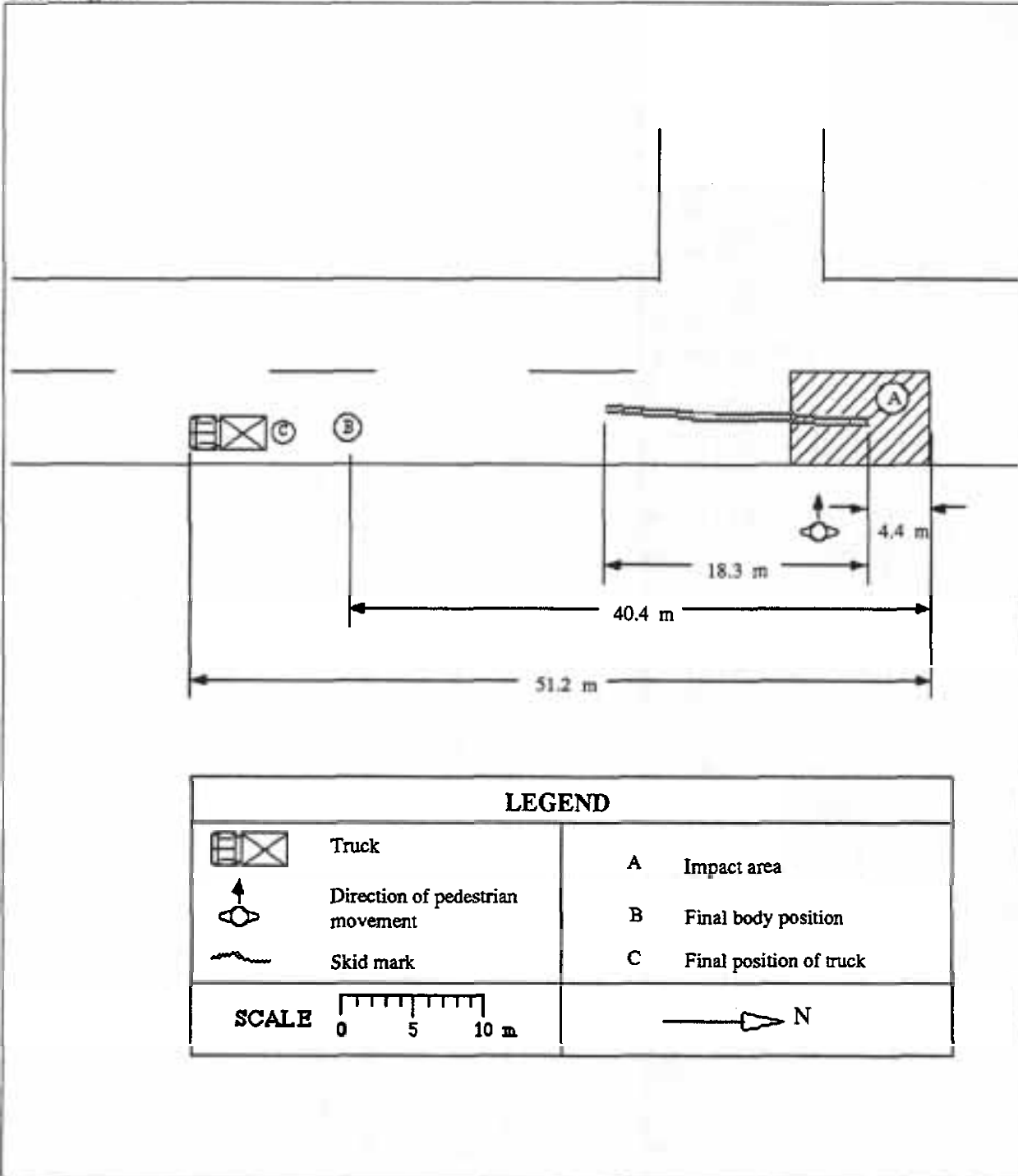

Accident Description

The vehicle was travelling in a southerly direction at 60 km/hr. The driver saw two pedestrians standing on the eastern footpath. When he was about 2 metres away (probably an under estimate) one pedestrian ran west across the path of the truck. The vehicle struck the pedestrian in the area A. The driver braked as soon as he realised the accident was going to happen. The pedestrian was hit on her right hand side by the front of the truck, just left of the drivers seat. She was carried along in front of the truck and then fell underneath. The truck's front wheels ran over her and a rear wheel ran over her head. The body came to rest at point B. The truck stopped at point C.

Case Details

<i>Case Number</i>	88 - H011	<i>Case type</i>	Driver unconscious
<i>Date of Accident</i>	Saturday, March	<i>Time</i>	3 am
<i>Speed Limit</i>	60 km/hr	<i>Number of Pedestrians Involved</i>	1
<i>Travel Speed</i>	75 km/hr	<i>Travel Speed Source</i>	Driver

Pedestrian Details

<i>Fatal</i>	Yes
<i>Age</i>	26
<i>Sex</i>	Male
<i>BAC Pedestrian</i>	Unknown %
<i>Action</i>	Walking
<i>Movement</i>	Following the road
<i>Side Impacted</i>	Back to vehicle

Driver Details

<i>Age</i>	Unknown
<i>Sex</i>	Unknown
<i>BAC Driver</i>	Unknown %
<i>Driving Experience</i>	Unknown years
<i>Licence Type</i>	Unknown
<i>Driver Action</i>	No attempt made to avoid collision

Impact Vehicle Details

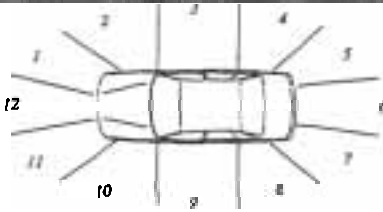
<i>Vehicle Model</i>	Unknown	<i>Impact Point</i> 11	
<i>Type</i>	Car		
<i>Number Involved</i>	1		
<i>Modifications</i>	None		

Road Site Details

<i>Traffic Control of Area</i>	None	<i>Road Type</i>	Other main traffic route
<i>Traffic Conditions</i>	Light	<i>Road Alignment</i>	Straight
<i>Weather Conditions</i>	Fine, dry road	<i>Natural Lighting</i>	Night
<i>Number of Lanes</i>	2	<i>Street Lighting</i>	None
<i>Road Division</i>	Line		

ite Diagram

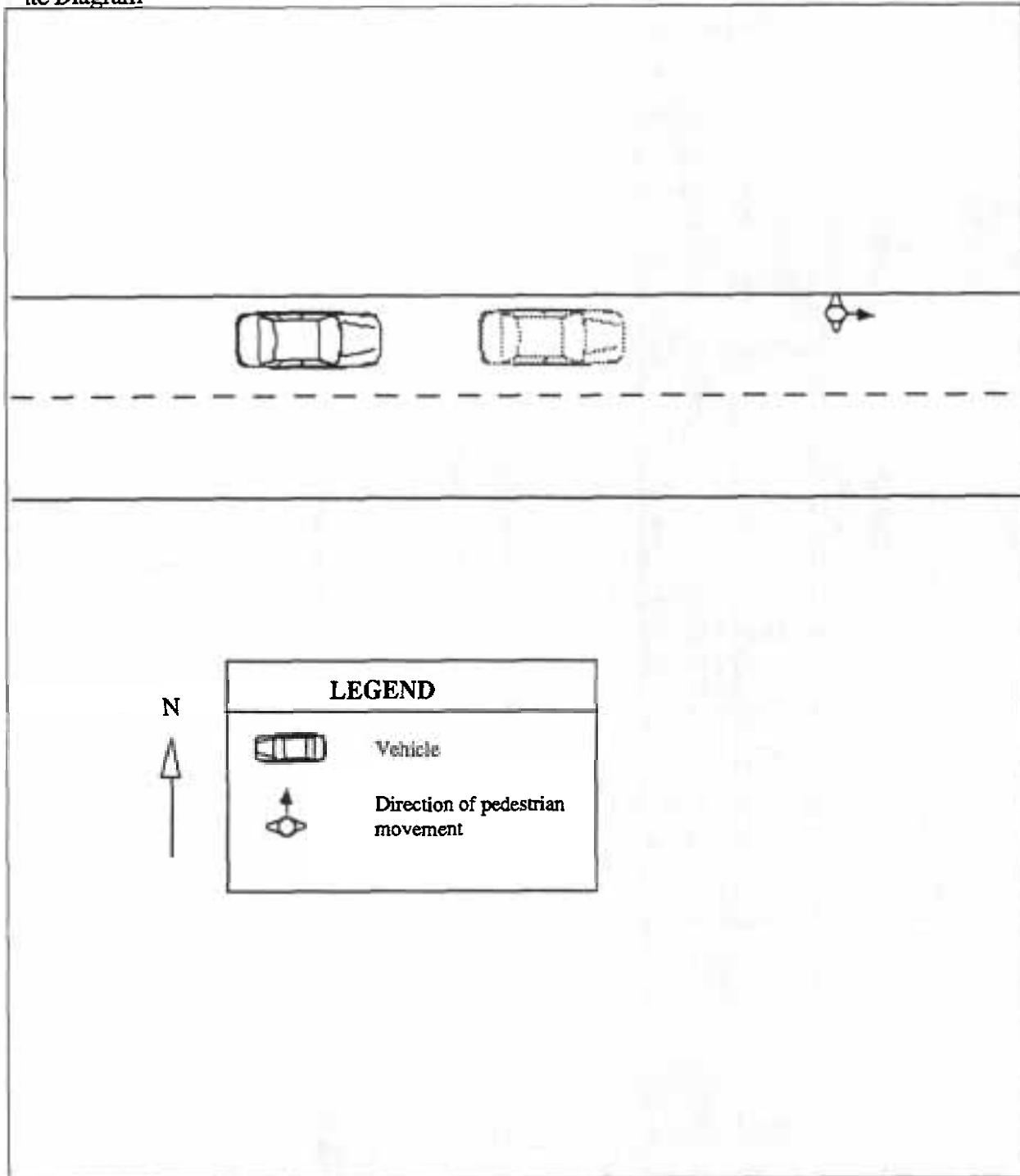

Accident Description

The driver stated that he had fallen asleep while he was travelling east at a speed between 70 to 80 km/hr. The vehicle then collided with a pedestrian walking east along the road.

Case Details

<i>Case Number</i>	88 - H022	<i>Case type</i>	Manoeuvre
<i>Date of Accident</i>	Saturday, June	<i>Time</i>	1 pm
<i>Speed Limit</i>	60 km/hr	<i>Number of Pedestrians Involved</i>	1
<i>Travel Speed</i>	Unknown km/hr	<i>Travel Speed Source</i>	Unknown

Pedestrian Details

<i>Fatal</i>	Yes
<i>Age</i>	68
<i>Sex</i>	Male
<i>BAC Pedestrian</i>	Unknown %
<i>Action</i>	Unknown
<i>Movement</i>	Unknown
<i>Side Impacted</i>	Unknown

Driver Details

<i>Age</i>	Unknown
<i>Sex</i>	Unknown
<i>BAC Driver</i>	Unknown %
<i>Driving Experience</i>	Unknown years
<i>Licence Type</i>	Unknown
<i>Driver Action</i>	Unknown

Impact Vehicle Details

<i>Vehicle Model</i>	Unknown	<i>Impact Point</i>	
<i>Type</i>	Car		
<i>Number Involved</i>	3		
<i>Modifications</i>	Unknown		

Road Site Details

<i>Traffic Control of Area</i>	Traffic signal at intersection	<i>Road Type</i>	Arterial
<i>Traffic Conditions</i>	Moderate	<i>Road Alignment</i>	Not applicable
<i>Weather Conditions</i>	Fine , dry road	<i>Natural Lighting</i>	Day
<i>Number of Lanes</i>	3	<i>Street Lighting</i>	Not applicable
<i>Road Division</i>	Line		

Site Diagram

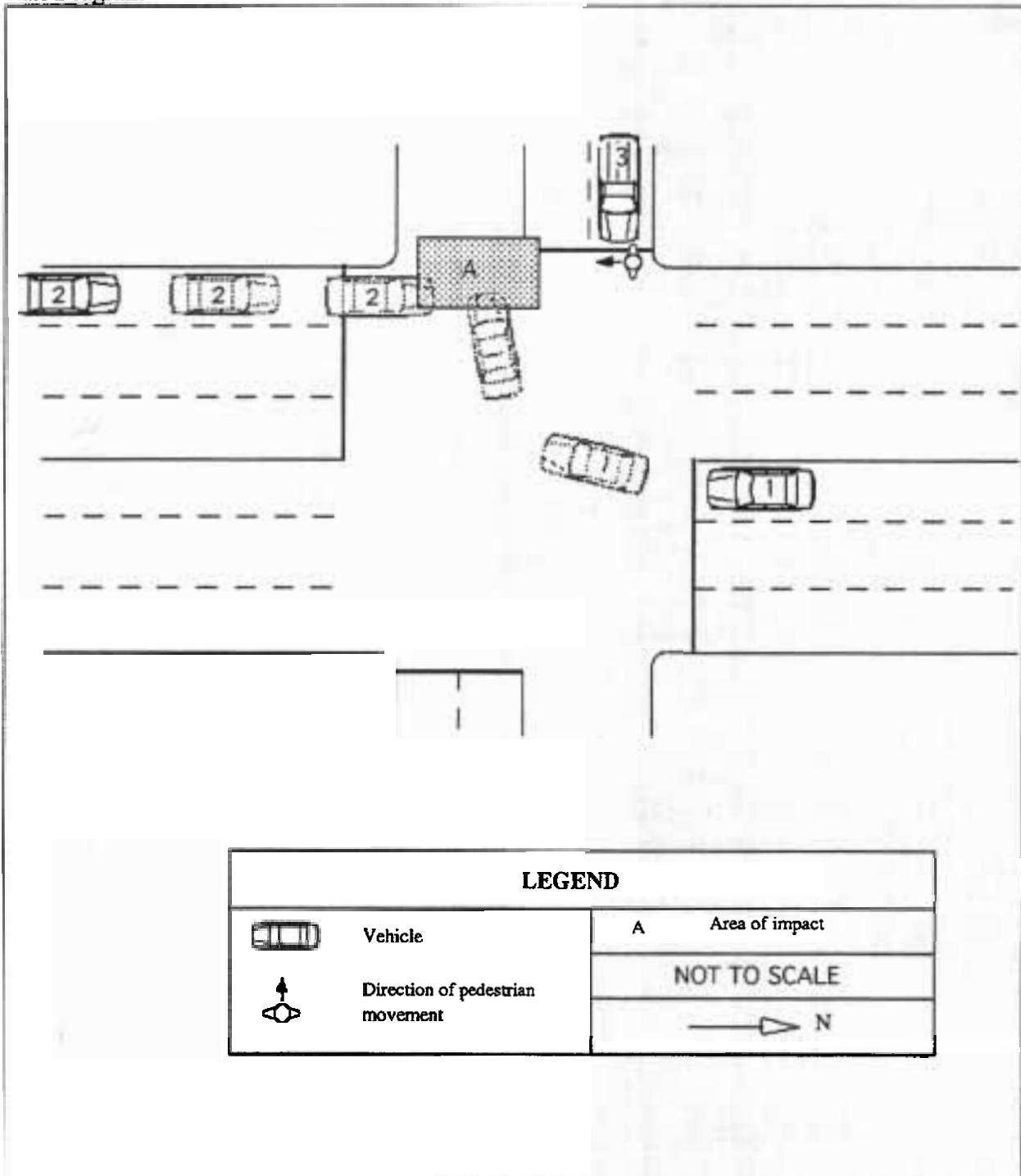

Accident Description

Three vehicles were involved in this case. Vehicle 1 was travelling south and turning right at an intersection. Vehicle 2 was travelling south collided with vehicle 1 as vehicle 1 was turning. Vehicle 1 then collided with vehicle 3 which was stationary facing east at the intersection. The driver of vehicle 2 stated that she was travelling about 60 km/hr. The driver of vehicle 3 stated that the pedestrian was crossing the road in a southerly direction in front of her. It was not known how or which vehicle collided with the pedestrian.

Case Details

<i>Case Number</i>	88 - H026	<i>Case type</i>	Insufficient information
<i>Date of Accident</i>	Sunday, July	<i>Time</i>	12 am
<i>Speed Limit</i>	60 km/hr	<i>Number of Pedestrians Involved</i>	1
<i>Travel Speed</i>	Unknown km/hr	<i>Travel Speed Source</i>	Unknown

Pedestrian Details

<i>Fatal</i>	Yes
<i>Age</i>	42
<i>Sex</i>	Male
<i>BAC Pedestrian</i>	.305 %
<i>Action</i>	Walking
<i>Movement</i>	Crossing the road
<i>Side Impacted</i>	Left side to vehicle

Driver Details

<i>Age</i>	Unknown
<i>Sex</i>	Unknown
<i>BAC Driver</i>	0 %
<i>Driving Experience</i>	Unknown years
<i>Licence Type</i>	Unknown
<i>Driver Action</i>	Unknown

Impact Vehicle Details

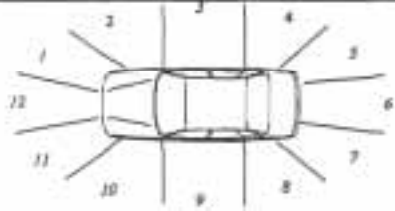
<i>Vehicle Model</i>	1977 Holden HX	<i>Impact Point</i> 1	
<i>Type</i>	Car		
<i>Number Involved</i>	2		
<i>Modifications</i>	None		

Road Site Details

<i>Traffic Control of Area</i>	None	<i>Road Type</i>	Local street
<i>Traffic Conditions</i>	Light	<i>Road Alignment</i>	Straight
<i>Weather Conditions</i>	Fine , dry road	<i>Natural Lighting</i>	Night
<i>Number of Lanes</i>	2	<i>Street Lighting</i>	Street lights
<i>Road Division</i>	Painted median strip		

Site Diagram

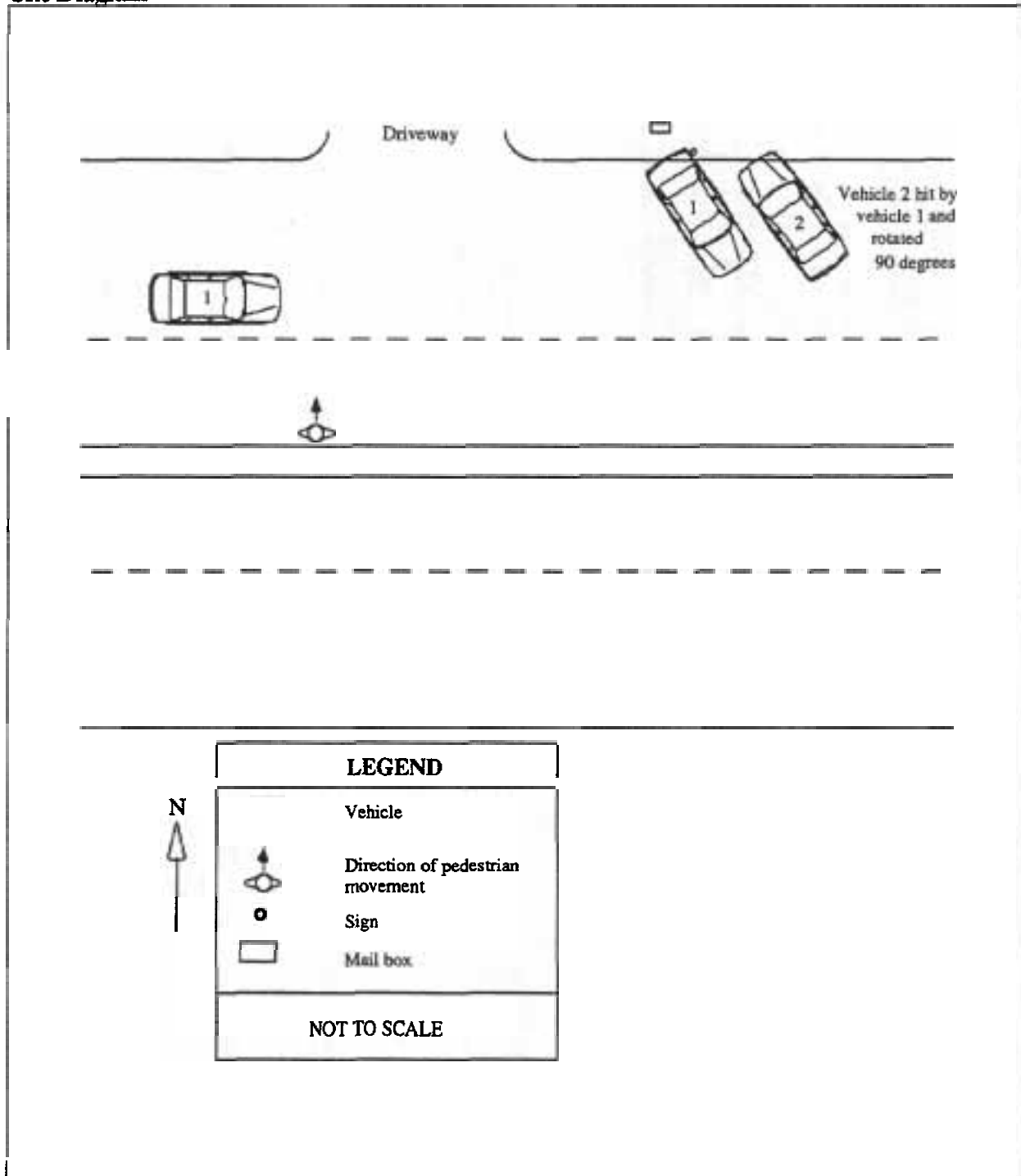

Accident Description

A pedestrian was walking north across the road when he was hit by an east bound vehicle (Vehicle 1). The vehicle then collided with a parked car (Vehicle 2). There was no other information available.

Case Details

<i>Case Number</i>	88 - H029	<i>Case type</i>	Insufficient information
<i>Date of Accident</i>	Tuesday, July	<i>Time</i>	3 pm
<i>Speed Limit</i>	60 km/hr	<i>Number of Pedestrians Involved</i>	1
<i>Travel Speed</i>	60 km/hr	<i>Travel Speed Source</i>	Driver

Pedestrian Details

<i>Fatal</i>	Yes
<i>Age</i>	67
<i>Sex</i>	Female
<i>BAC Pedestrian</i>	0 %
<i>Action</i>	Walking
<i>Movement</i>	Crossing the road
<i>Side Impacted</i>	Right side to vehicle

Driver Details

<i>Age</i>	Unknown
<i>Sex</i>	Unknown
<i>BAC Driver</i>	0 %
<i>Driving Experience</i>	Unknown years
<i>Licence Type</i>	Unknown
<i>Driver Action</i>	Braked before impact

Impact Vehicle Details

<i>Vehicle Model</i>	1971 Chrysler Valiant Charger	<i>Impact Point</i>	12
<i>Type</i>	Car		
<i>Number Involved</i>	1		
<i>Modifications</i>	None		

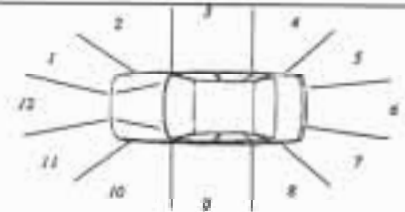

Road Site Details

<i>Traffic Control of Area</i>	None	<i>Road Type</i>	Arterial
<i>Traffic Conditions</i>	Moderate	<i>Road Alignment</i>	Straight
<i>Weather Conditions</i>	Fine , dry road	<i>Natural Lighting</i>	Day
<i>Number of Lanes</i>	2	<i>Street Lighting</i>	Not applicable
<i>Road Division</i>	Painted median strip		

Site Diagram

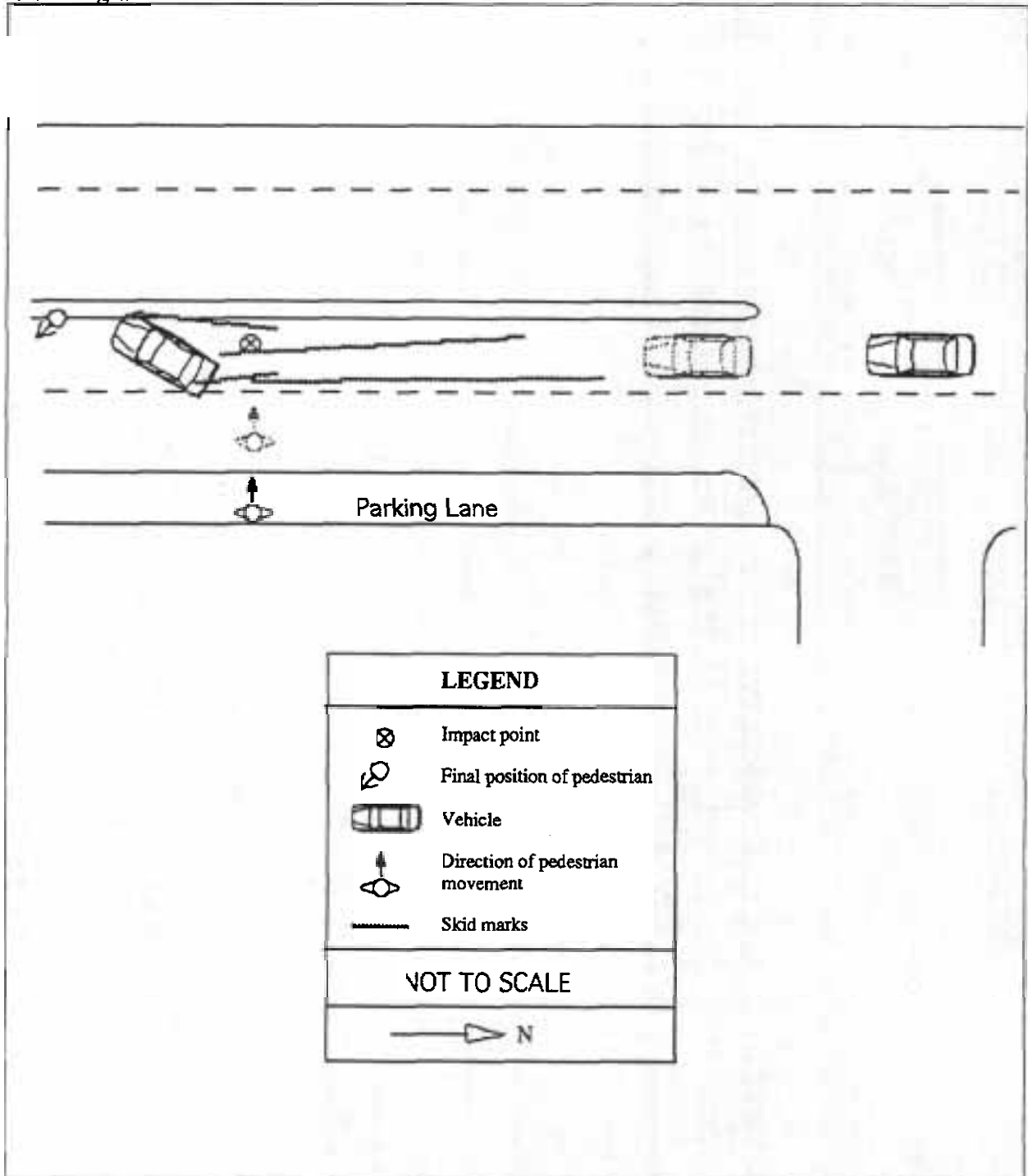

Accident Description

The vehicle was travelling south in the right lane and collided with a pedestrian crossing the road from east to west. The driver stated that he was travelling approximately 60 km/hr when he came over the crest of a hill and first observed the pedestrian on the footpath to his left. The pedestrian had started to cross the road as he approached, crossing from left to right in front of his vehicle. He slowed down slightly but expected the pedestrian to stop at the lane marking to allow him to pass. The pedestrian did not stop and continued to cross the road into the path of his vehicle. He braked hard before impact, locking his wheels, leaving faint tyre marks on the road. Length of skids marks were not recorded.

Case Details

<i>Case Number</i>	88 - H034	<i>Case type</i>	Manoeuvre
<i>Date of Accident</i>	Monday, September	<i>Time</i>	11 am
<i>Speed Limit</i>	60 km/hr	<i>Number of Pedestrians Involved</i>	2
<i>Travel Speed</i>	10 km/hr	<i>Travel Speed Source</i>	Witness

Pedestrian 1 Details

<i>Fatal</i>	Yes
<i>Age</i>	56
<i>Sex</i>	Female
<i>BAC Pedestrian</i>	0 %
<i>Action</i>	Walking
<i>Movement</i>	Crossing the road
<i>Side Impacted</i>	Right side to vehicle

Pedestrian 2 Details

<i>Fatal</i>	No
<i>Age</i>	Unknown
<i>Sex</i>	Female
<i>BAC Pedestrian</i>	Unknown %
<i>Action</i>	Walking
<i>Movement</i>	Crossing the road
<i>Side Impacted</i>	Right side to vehicle

<i>Age</i>	54	<i>Driving Experience</i>	40 years	<i>Driver Action</i>	Braked before impact
<i>Sex</i>	Male	<i>Licence Type</i>	Full		
		<i>BAC Driver</i>	0 %		

Impact Vehicle Details

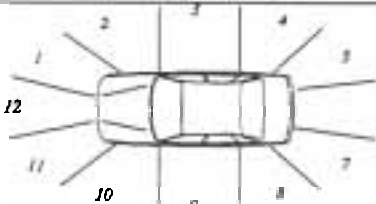
<i>Vehicle Model</i>	1978 Daihatsu 4WD	<i>Impact Point</i>	1	
<i>Type</i>	Multi purpose vehicle			
<i>Number Involved</i>	1			
<i>Modifications</i>	Bull Bar			

Road Site Details

<i>Traffic Control of Area</i>	None	<i>Road Type</i>	Arterial
<i>Traffic Conditions</i>	Moderate	<i>Road Alignment</i>	Straight
<i>Weather Conditions</i>	Fine , dry road	<i>Natural Lighting</i>	Day
<i>Number of Lanes</i>	3	<i>Street Lighting</i>	Not applicable
<i>Road Division</i>	Raised median strip		

Site Diagram

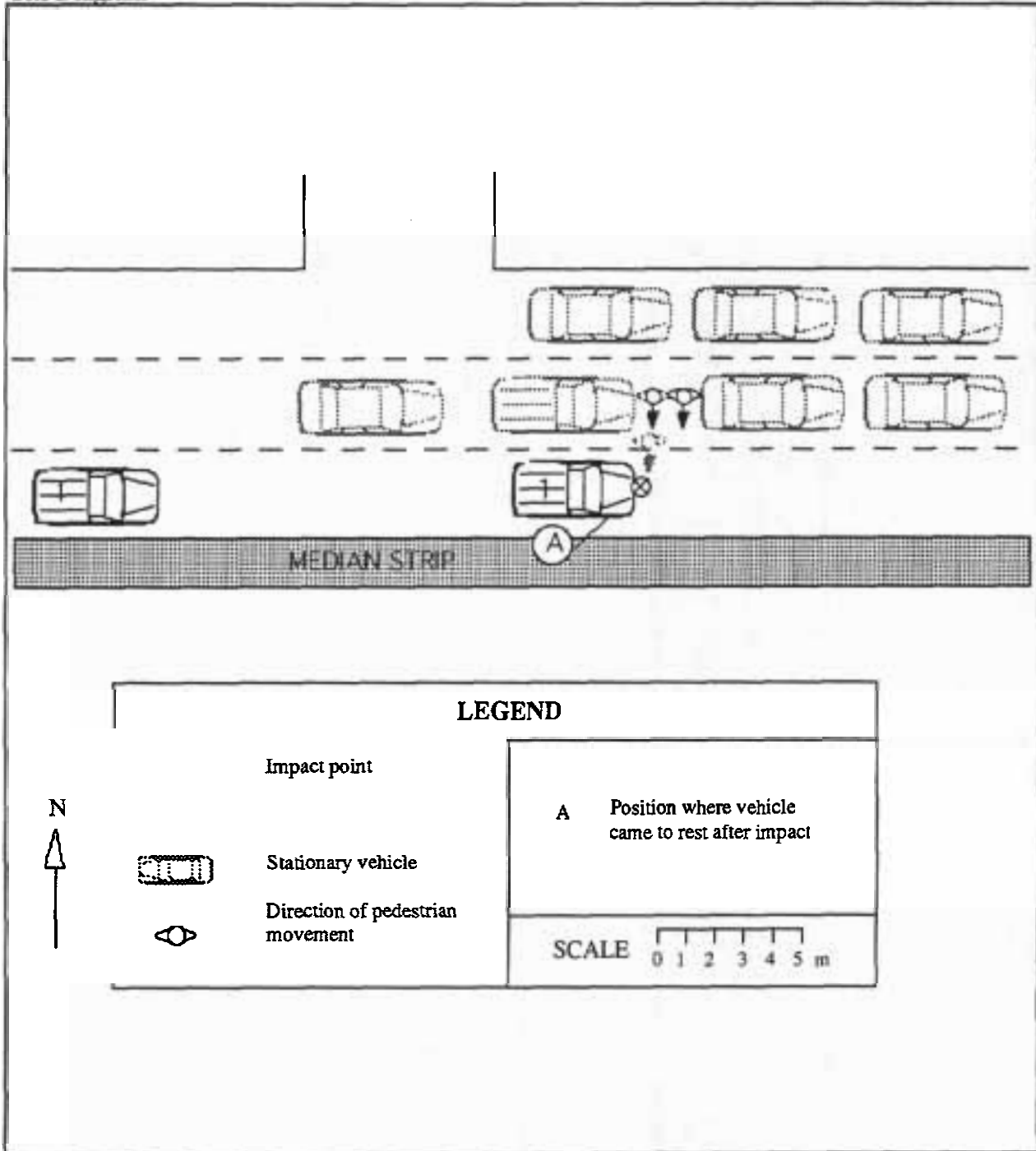

Accident Description

Vehicle was travelling in a easterly direction in the right hand lane on a three lane road for east bound traffic. The vehicular traffic had stopped in the centre lane and left lanes. There was no vehicles in front of the driver for about 30 metres. The driver stated that he did not see the approach of two pedestrians until they walked in front of the driver, approximately two metres into the right traffic lane from the front of a stationary vehicle on the centre lane. One of the pedestrian survived with minor injuries but the other later died in hospital. The driver was reported to be travelling about 10 km/hr.

<i>Case Number</i>	88 - H044	<i>Case type</i>	Manoeuvre
<i>Date of Accident</i>	Saturday, November	<i>Time</i>	1 pm
<i>Speed Limit</i>	60 km/hr	<i>Number of Pedestrians Involved</i>	1
<i>Travel Speed</i>	60 km/hr	<i>Travel Speed Source</i>	Driver and witness

<i>Fatal</i>	Yes
<i>Age</i>	8
<i>Sex</i>	Female
<i>BAC Pedestrian</i>	Unknown %
<i>Action</i>	Walking
<i>Movement</i>	Following the road
<i>Side Impacted</i>	Unknown

<i>Age</i>	67
<i>Sex</i>	Female
<i>BAC Driver</i>	Unknown %
<i>Driving Experience</i>	Unknown years
<i>Licence Type</i>	Full
<i>Driver Action</i>	Unknown

Impact Vehicle Details

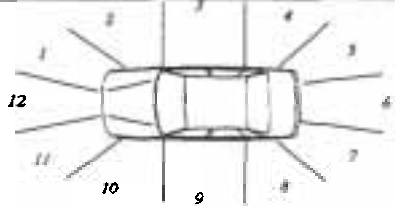
<i>Vehicle Model</i>	Holden Camira	<i>Impact Point</i> 9	
<i>Type</i>	Car		
<i>Number Involved</i>	1		
<i>Modifications</i>	None		

Road Site Details

<i>Traffic Control of Area</i>	None	<i>Road Type</i>	Arterial
<i>Traffic Conditions</i>	Light	<i>Road Alignment</i>	Straight
<i>Weather Conditions</i>	Fine , dry road	<i>Natural Lighting</i>	Day
<i>Number of Lanes</i>	2	<i>Street Lighting</i>	Not applicable
<i>Road Division</i>	Painted median strip		

Site Diagram

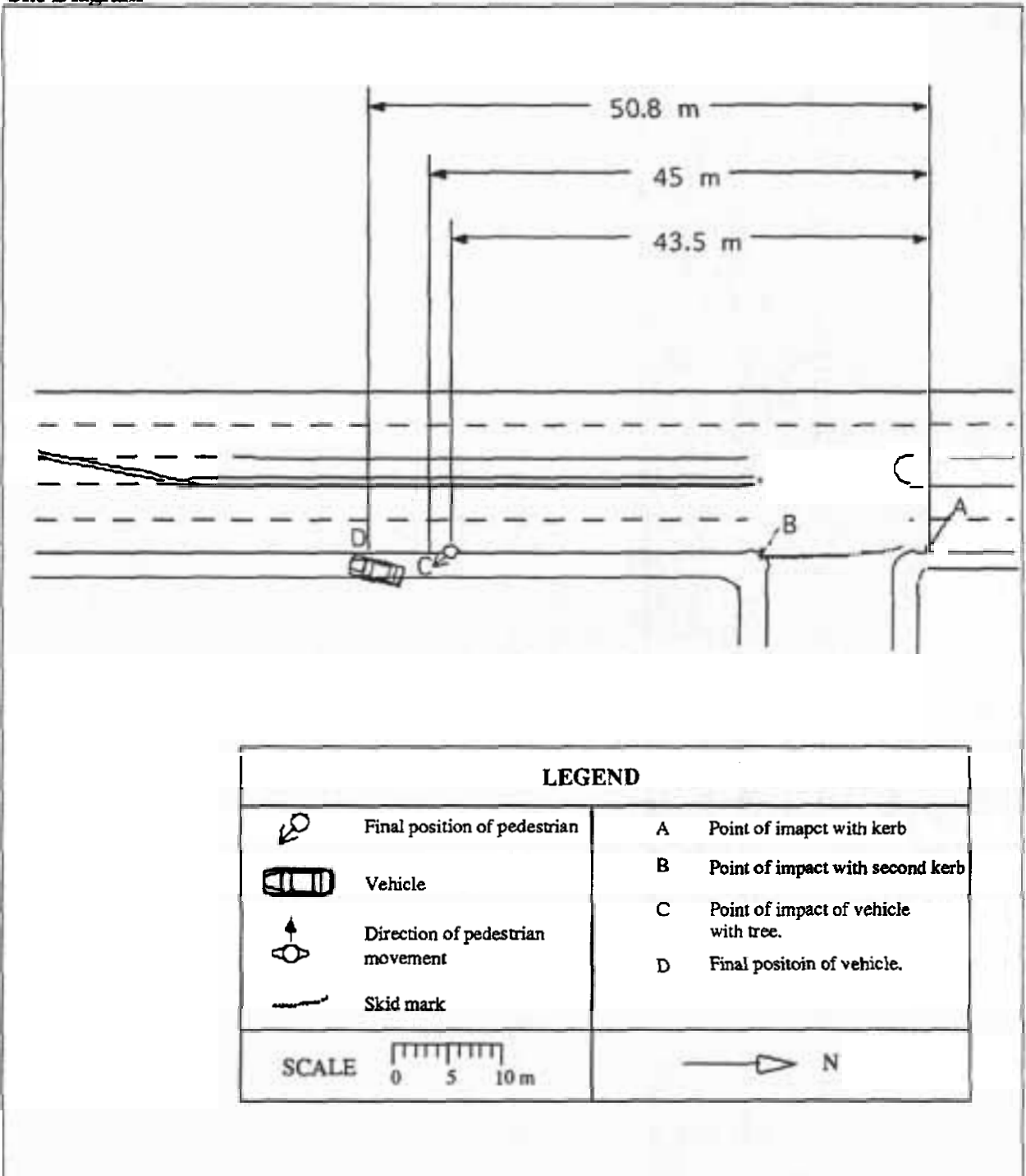

Accident Description

The vehicle was travelling in a southerly direction and due to the driver's inattention, wandered to the left striking the kerb with the left front wheel. This caused the immediate deflation of that tyre, and resulted in the loss of control of the vehicle, which then mounted the eastern footpath and collided with the pedestrian and then a tree. The pedestrian was walking in a northerly direction. The driver stated that she was travelling about 45 - 60 km/hr before colliding with the kerb.

Case Details

<i>Case Number</i>	89 - H006	<i>Case type</i>	Insufficient information
<i>Date of Accident</i>	Wednesday, January	<i>Time</i>	11 am
<i>Speed Limit</i>	60 km/hr	<i>Number of Pedestrians Involved</i>	1
<i>Travel Speed</i>	60 km/hr	<i>Travel Speed Source</i>	Unknown

Pedestrian Details

<i>Fatal</i>	Yes
<i>Age</i>	71
<i>Sex</i>	Male
<i>BAC Pedestrian</i>	0 %
<i>Action</i>	Walking
<i>Movement</i>	Crossing the road
<i>Side Impacted</i>	Right side to vehicle

Driver Details

<i>Age</i>	24
<i>Sex</i>	Male
<i>BAC Driver</i>	0 %
<i>Driving Experience</i>	8 years
<i>Licence Type</i>	Full
<i>Driver Action</i>	Braked before impact

Impact Vehicle Details

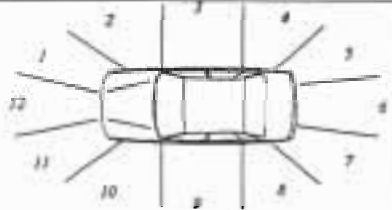
<i>Vehicle Model</i>	1970 Toyota Corolla	
<i>Type</i>	Car	
<i>Number Involved</i>	1	
<i>Modifications</i>	None	

Road Site Details

<i>Traffic Control of Area</i>	None	<i>Road Type</i>	Arterial
<i>Traffic Conditions</i>	Moderate	<i>Road Alignment</i>	Straight
<i>Weather Conditions</i>	Fine , dry road	<i>Natural Lighting</i>	Day
<i>Number of Lanes</i>	4	<i>Street Lighting</i>	Not applicable
<i>Road Division</i>	Raised median strip		

Site Diagram

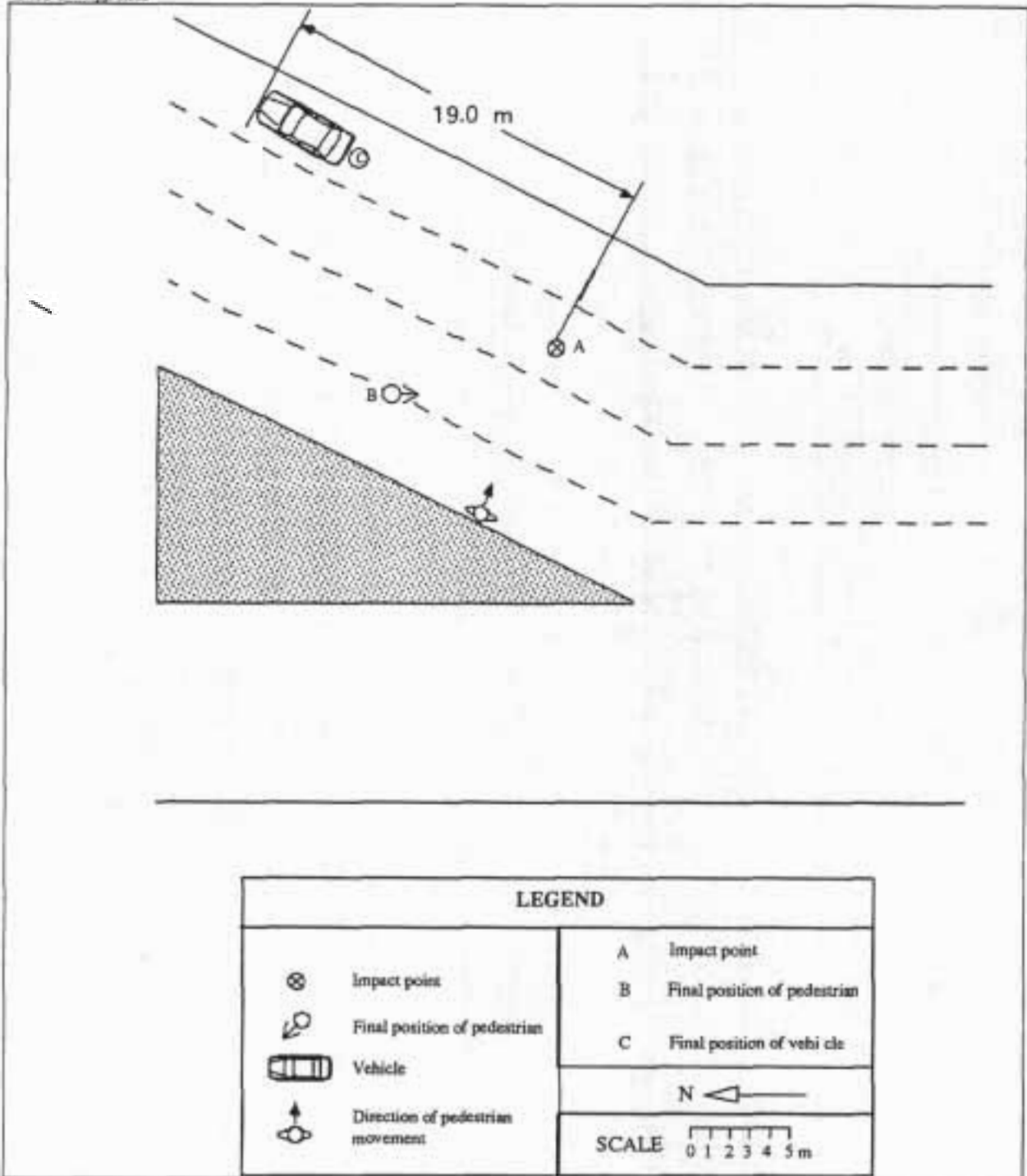

Accident Description

The car was travelling in a northerly direction at 60 km/hr in the second lane from the right. The pedestrian was walking in a easterly direction following a group of people. The driver saw the pedestrian a fair way ahead and when he was 10 metres away (at point D) he realised an accident was going to occur. He braked hard and impacted with the pedestrian at point A. The pedestrian was struck on his right hand side by the front right of the vehicle and was thrown in the air and fell to the road on the right side of the vehicle. The car continued and stopped at point C.

Case Details

<i>Case Number</i>	89 - H018	<i>Case type</i>	Insufficient information
<i>Date of Accident</i>	Saturday, April	<i>Time</i>	12 pm
<i>Speed Limit</i>	60 km/hr	<i>Number of Pedestrians Involved</i>	2
<i>Travel Speed</i>	37 km/hr	<i>Travel Speed Source</i>	Driver

Pedestrian 1 Details

<i>Fatal</i>	Yes
<i>Age</i>	79
<i>Sex</i>	Female
<i>BAC Pedestrian</i>	0%
<i>Action</i>	Walking
<i>Movement</i>	Crossing the road
<i>Side Impacted</i>	Left side to vehicle

Pedestrian 2 Details

<i>Fatal</i>	No
<i>Age</i>	Unknown
<i>Sex</i>	Unknown
<i>BAC Pedestrian</i>	Unknown %
<i>Action</i>	Walking
<i>Movement</i>	Crossing the road
<i>Side Impacted</i>	Left side to vehicle

Driver Details

<i>Age</i>	36	<i>Driving Experience</i>	20 years	<i>Driver Action</i>	Braked before impact
<i>Sex</i>	Male	<i>Licence Type</i>	Full		
		<i>BAC Driver</i>	0%		

Impact Vehicle Details

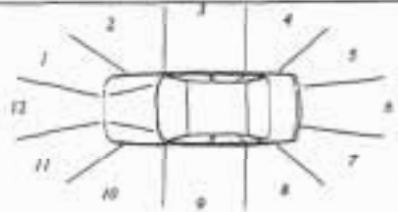
<i>Vehicle Model</i>	Dodge utility	<i>Impact Point</i>	11	
<i>Type</i>	Car			
<i>Number Involved</i>	1			
<i>Modifications</i>	None			

Road Site Details

<i>Traffic Control of Area</i>	None	<i>Road Type</i>	Arterial
<i>Traffic Conditions</i>	Moderate	<i>Road Alignment</i>	Straight
<i>Weather Conditions</i>	Fine , dry road	<i>Natural Lighting</i>	Day
<i>Number of Lanes</i>	1	<i>Street Lighting</i>	Not applicable
<i>Road Division</i>	Line		

ite Diagram

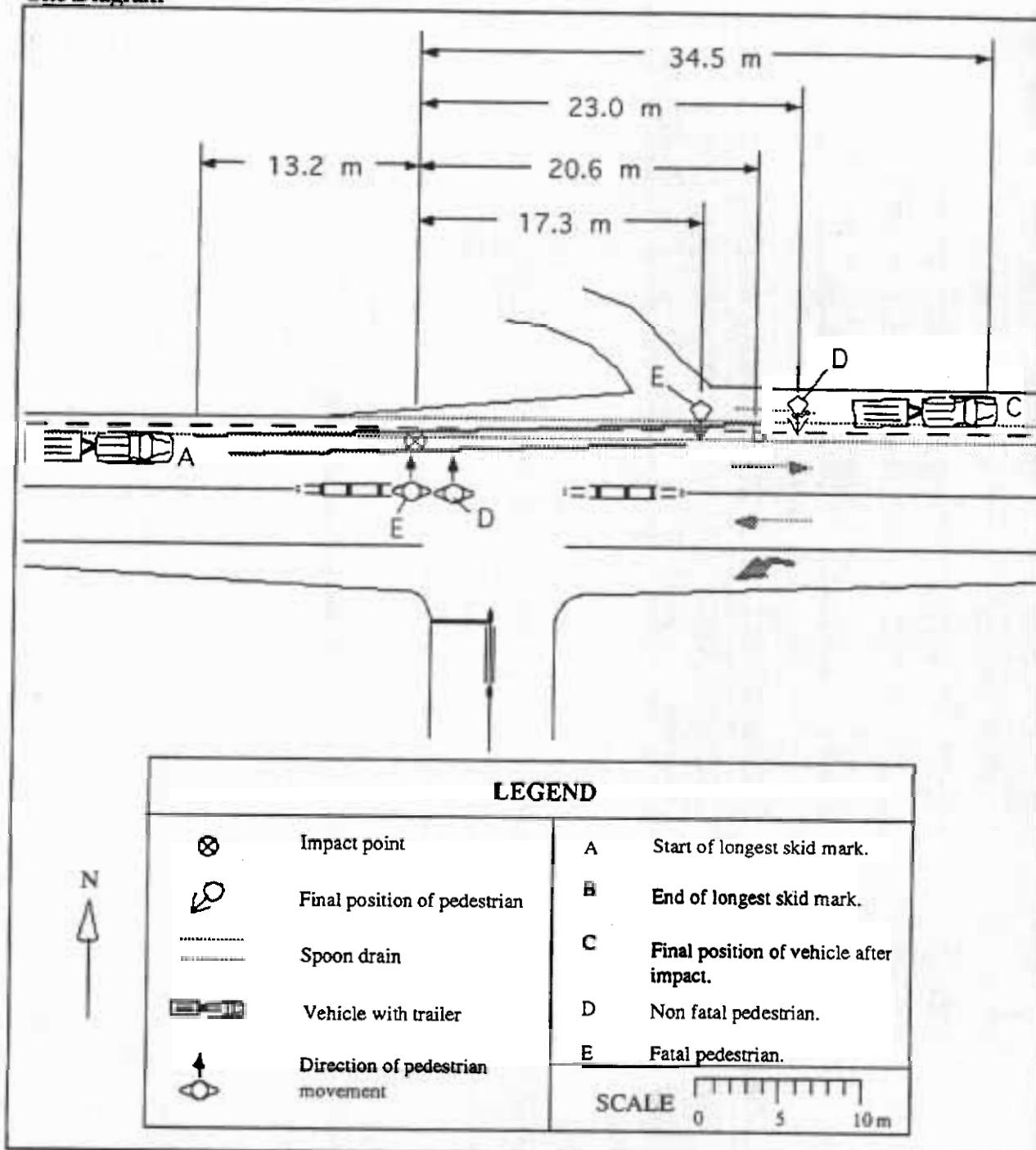

Accident Description

The vehicle, a Dodge utility towing a trailer, was travelling in a easterly direction when it collided with two elderly pedestrians crossing the road from south to north, resulting in the death of one of them. The driver stated that he was travelling about 37 km/hr and saw the pedestrians about 60 metres away. The pedestrians were crossing the road in a northerly direction. When the pedestrians reached the centre of the road, they continued to walk into the path of the oncoming vehicle. The driver braked heavily before impact and diverged to the left. The Dodge utility weighed 2.68 tons and the trailer weighed 2.26 tons. The road was downhill in the direction of travel of the vehicle with a gradient of 1.1 degrees. Due to the increased weight of the car by towing the trailer, there was an increased stopping distance.

Case Details

<i>Case Number</i>	89 - H028	<i>Case type</i>	Insufficient information
<i>Date of Accident</i>	Tuesday, July	<i>Time</i>	12 pm
<i>Speed Limit</i>	80 km/hr	<i>Number of Pedestrians Involved</i>	1
<i>Travel Speed</i>	65 km/hr	<i>Travel Speed Source</i>	Driver and witness

Pedestrian Details

<i>Fatal</i>	Yes
<i>Age</i>	84
<i>Sex</i>	Male
<i>BAC Pedestrian</i>	.026 %
<i>Action</i>	Walking
<i>Movement</i>	Crossing the road
<i>Side Impacted</i>	Right side to vehicle

Driver Details

<i>Age</i>	Unknown
<i>Sex</i>	Unknown
<i>BAC Driver</i>	Unknown %
<i>Driving Experience</i>	Unknown years
<i>Licence Type</i>	Unknown
<i>Driver Action</i>	Brake after impact

Impact Vehicle Details

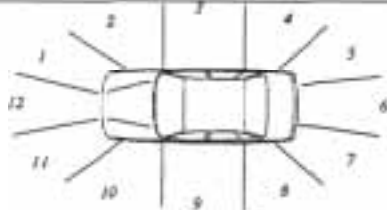
<i>Vehicle Model</i>	Morris sedan	
<i>Type</i>	Car	
<i>Number Involved</i>	1	
<i>Modifications</i>	None	
<i>Impact Point</i>	11	

Road Site Details

<i>Traffic Control of Area</i>	Traffic signal at intersection	<i>Road Type</i>	Arterial
<i>Traffic Conditions</i>	Moderate	<i>Road Alignment</i>	Straight
<i>Weather Conditions</i>	Fine , dry road	<i>Natural Lighting</i>	Day
<i>Number of Lanes</i>	3	<i>Street Lighting</i>	Not applicable
<i>Road Division</i>	Raised median strip		

Site Diagram

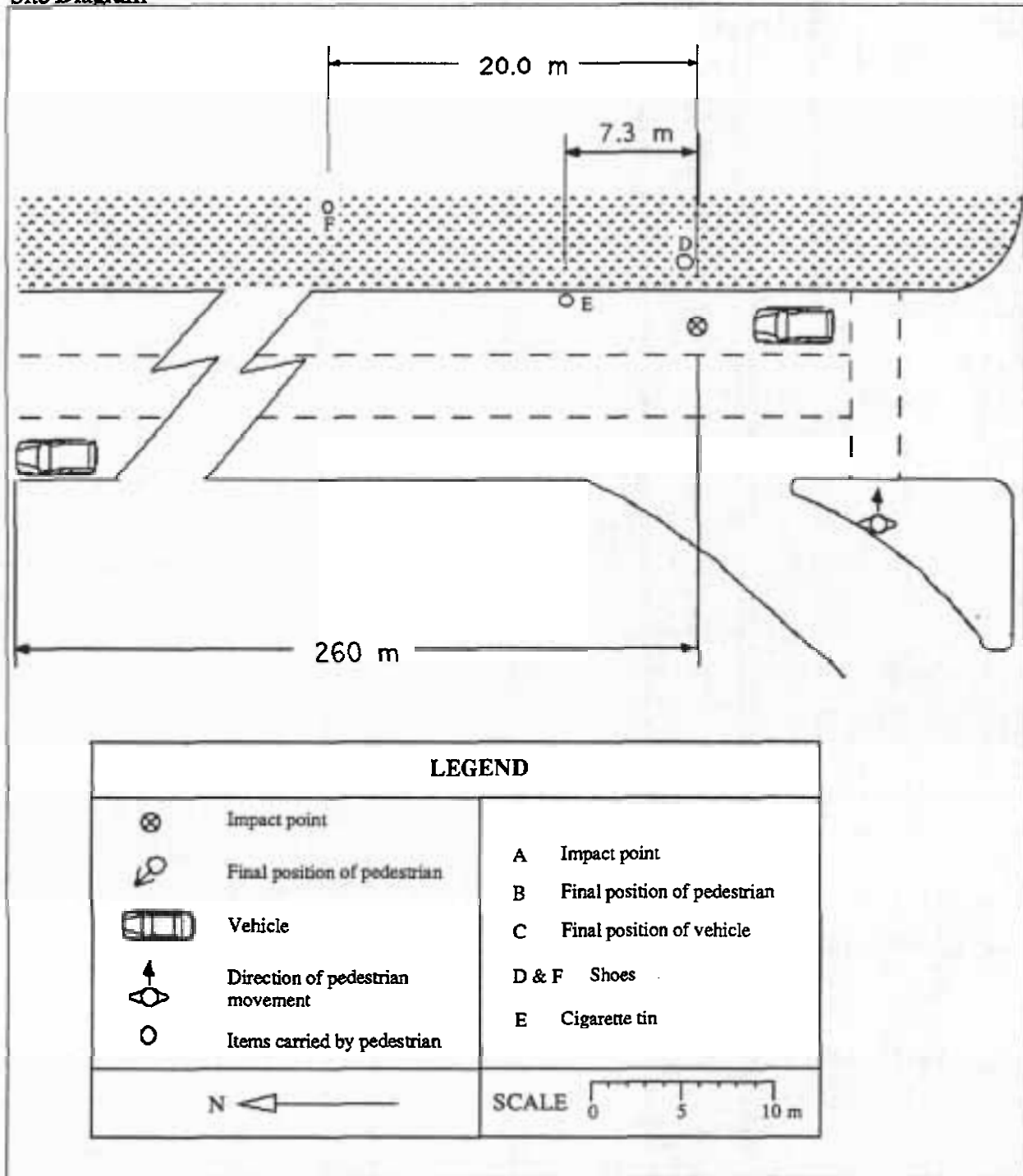

Accident Description

The vehicle was travelling in a southerly direction at a speed stated by the driver to be about 65 km/hr. The pedestrian was crossing the road in a westerly direction and was narrowly missed by the car in the left lane. He then stepped into the path of the vehicle. The driver braked heavily before impact. He then released the brakes and rolled to a stop. The pedestrian went through the windscreen and stopped on the front seat of the vehicle.

BLANK

**(CASE OUTSIDE THE ADELAIDE STATISTICAL DIVISION - CASE REMOVED
FROM SAMPLE)**

BLANK

**(CASE OUTSIDE THE ADELAIDE STATISTICAL DIVISION - CASE REMOVED
FROM SAMPLE)**

Case Details

<i>Case Number</i>	90 - H012	<i>Case type</i>	Insufficient information
<i>Date of Accident</i>	Monday, April	<i>Time</i>	11 pm
<i>Speed Limit</i>	80 km/hr	<i>Number of Pedestrians Involved</i>	1
<i>Travel Speed</i>	Unknown km/hr	<i>Travel Speed Source</i>	Unknown

Pedestrian Details

<i>Fatal</i>	Yes
<i>Age</i>	26
<i>Sex</i>	Female
<i>BAC Pedestrian</i>	0 %
<i>Action</i>	Walking
<i>Movement</i>	Following the road
<i>Side Impacted</i>	Back to vehicle

Driver Details

<i>Age</i>	Unknown
<i>Sex</i>	Unknown
<i>BAC Driver</i>	.155 %
<i>Driving Experience</i>	Unknown years
<i>Licence Type</i>	Unknown
<i>Driver Action</i>	No attempt made to avoid collision

Impact Vehicle Details

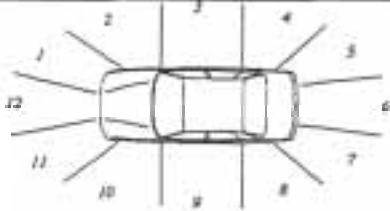
<i>Vehicle Model</i>	1976 Ford XB	
<i>Type</i>	Car	
<i>Number Involved</i>	1	
<i>Modifications</i>	None	

Road Site Details

<i>Traffic Control of Area</i>	None	<i>Road Type</i>	Arterial
<i>Traffic Conditions</i>	Unknown		
<i>Weather Conditions</i>	Fine , dry road	<i>Road Alignment</i>	Straight
<i>Number of Lanes</i>	1	<i>Natural Lighting</i>	Night
<i>Road Division</i>	Line	<i>Street Lighting</i>	None

Site Diagram

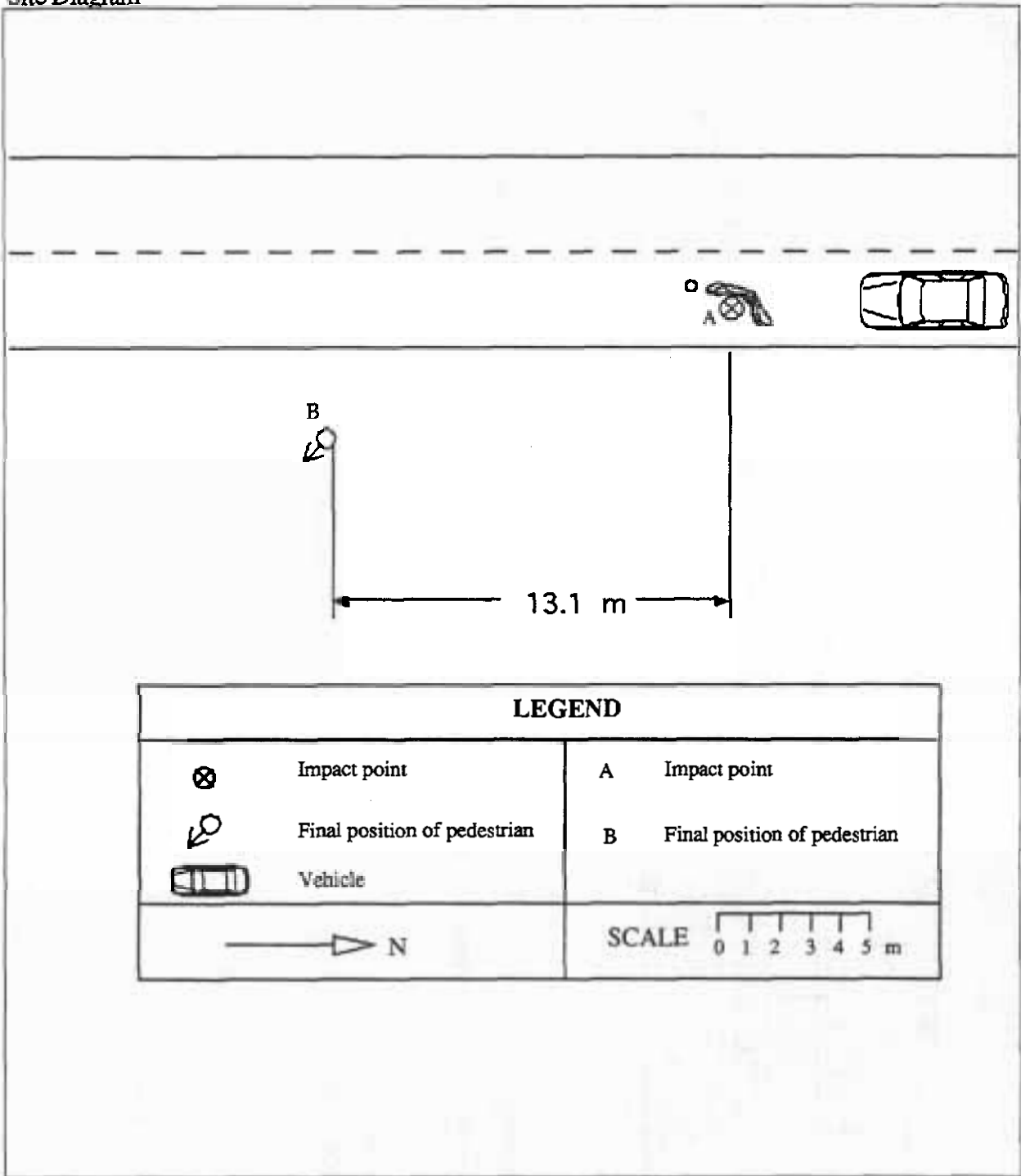

Accident Description

The pedestrian was walking with the traffic on a dark stretch of road and was hit from behind by a Ford Utility. The driver did not realise that he had collided with a pedestrian and drove home. Later he called the police and told the story and they took him to the scene to locate the impact point and find the body. This impact point was very approximate and could not be ascertained with any certainty.

Case Details

<i>Case Number</i>	90 - H019	<i>Case type</i>	Insufficient information
<i>Date of Accident</i>	Saturday, June	<i>Time</i>	1 pm
<i>Speed Limit</i>	60 km/hr	<i>Number of Pedestrians Involved</i>	1
<i>Travel Speed</i>	60 km/hr	<i>Travel Speed Source</i>	Driver

Pedestrian Details

<i>Fatal</i>	Yes
<i>Age</i>	21
<i>Sex</i>	Male
<i>BAC Pedestrian</i>	Unknown %
<i>Action</i>	Walking
<i>Movement</i>	Crossing the road
<i>Side Impacted</i>	Right side to vehicle

Driver Details

<i>Age</i>	25
<i>Sex</i>	Male
<i>BAC Driver</i>	0%
<i>Driving Experience</i>	9 years
<i>Licence Type</i>	Full
<i>Driver Action</i>	Braked before impact

Impact Vehicle Details

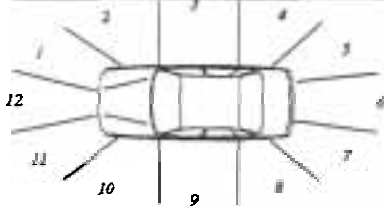
<i>Vehicle Model</i>	1981 Ford Falcon	
<i>Type</i>	Car	
<i>Number Involved</i>	1	
<i>Modifications</i>	None	
<i>Impact Point</i>	N/A	

Road Site Details

<i>Traffic Control of Area</i>	None	<i>Road Type</i>	Arterial
<i>Traffic Conditions</i>	Moderate	<i>Road Alignment</i>	Straight
<i>Weather Conditions</i>	Fine , wet road	<i>Natural Lighting</i>	Day
<i>Number of Lanes</i>	2	<i>Street Lighting</i>	Not applicable
<i>Road Division</i>	Raised median strip		

Site Diagram

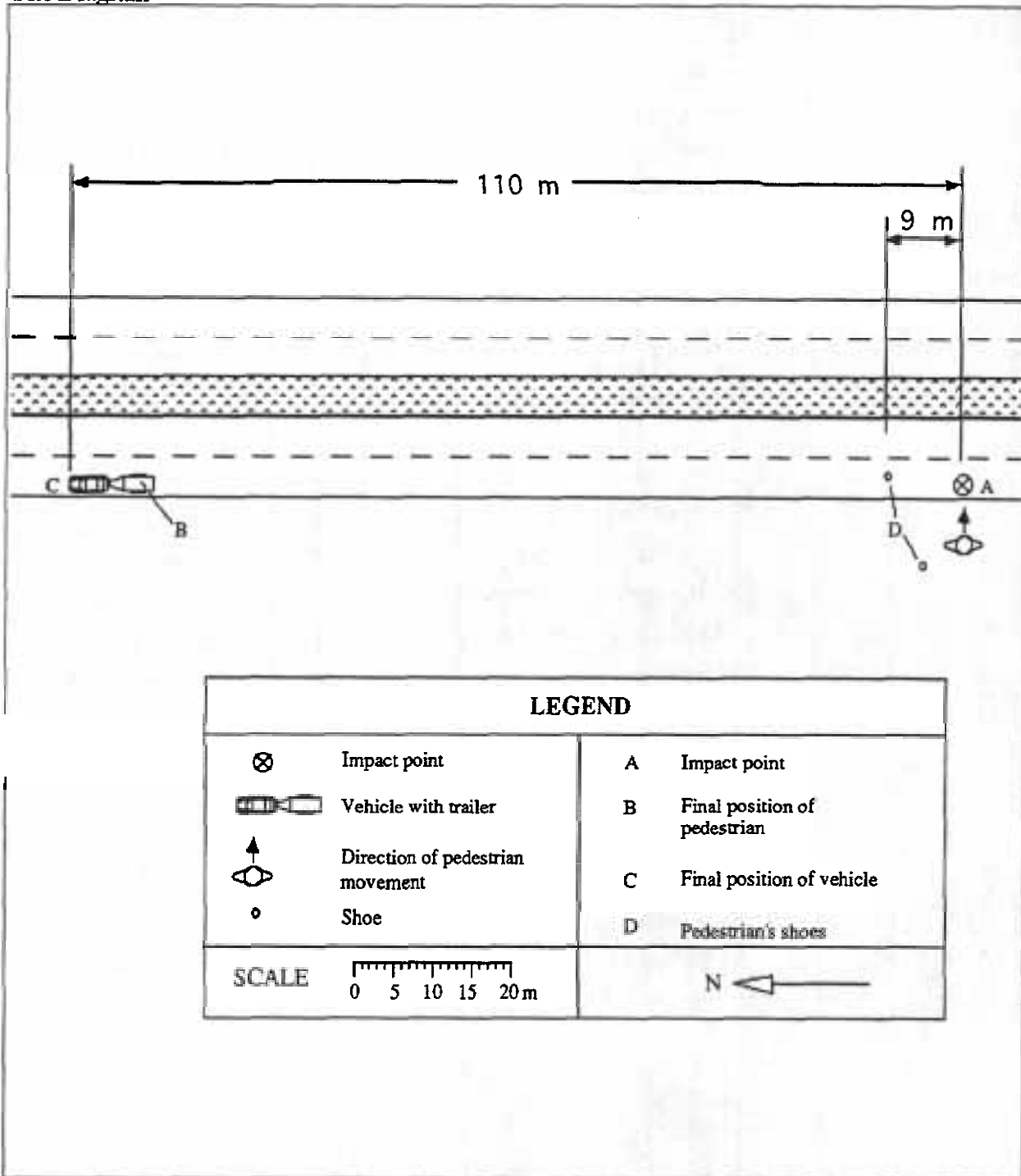

Accident Description

A Ford sedan towing a trailer was travelling south west. The pedestrian was crossing the road in a north westerly direction. The Ford braked hard and swerved right missing the pedestrian, but the left front corner of the trailer collided with him and he fell into the tray. It is difficult to determine the travel and impact speed due to the manoeuvring.

<i>Case Number</i>	90 - H029	<i>Case type</i>	Self induced
<i>Date of Accident</i>	Monday, September	<i>Time</i>	6 pm
<i>Speed Limit</i>	60 km/hr	<i>Number of Pedestrians Involved</i>	1
<i>Travel Speed</i>	50 km/hr	<i>Travel Speed Source</i>	Driver

Pedestrian Details

<i>Fatal</i>	Yes
<i>Age</i>	18
<i>Sex</i>	Male
<i>BAC Pedestrian</i>	0 %
<i>Action</i>	Running
<i>Movement</i>	None
<i>Side Impacted</i>	Right side to vehicle

Driver Details

<i>Age</i>	29
<i>Sex</i>	Male
<i>BAC Driver</i>	0 %
<i>Driving Experience</i>	5 years
<i>Licence Type</i>	Full
<i>Driver Action</i>	Braked before impact

Impact Vehicle Details

<i>Vehicle Model</i>	1978 Kenworth Prime mover / Trailer	
<i>Type</i>	Truck	
<i>Number Involved</i>	1	
<i>Modifications</i>	None	
<i>Impact Point</i>	12	

Road Site Details

<i>Traffic Control of Area</i>	None	<i>Road Type</i>	Arterial
<i>Traffic Conditions</i>	Moderate	<i>Road Alignment</i>	Straight
<i>Weather Conditions</i>	Fine , dry road	<i>Natural Lighting</i>	Dusk
<i>Number of Lanes</i>	2	<i>Street Lighting</i>	Street lights
<i>Road Division</i>	Raised median strip		

Site Diagram

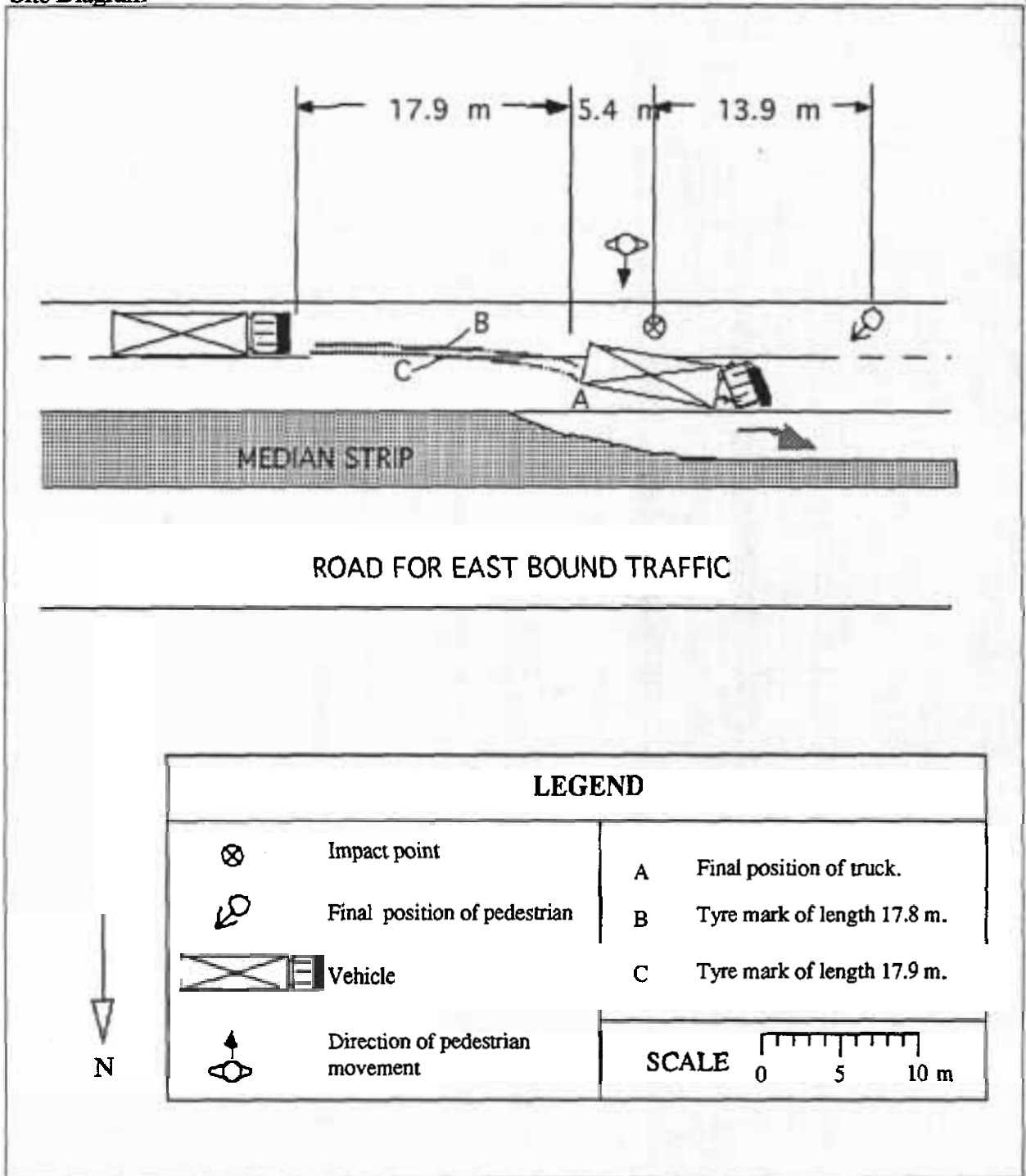

Accident Description

The vehicle, a semi trailer, was travelling south in the left lane at about 50 km/hr. The driver stated that he saw the pedestrian sitting on a stone brick wall on the eastern side of the road, the pedestrian then ran in the direction of the semi trailer when the vehicle was about 5 metres away. The driver braked and swerved to avoid the pedestrian but a collision occurred. The pedestrian was reported to be a psychiatric patient with suicidal tendencies. The accident was most probably orchestrated by the pedestrian for the sole purpose of taking his own life.

Case Details

<i>Case Number</i>	90 - H036	<i>Case type</i>	Manoeuvre
<i>Date of Accident</i>	Wednesday, November	<i>Time</i>	9 pm
<i>Speed Limit</i>	60 km/hr	<i>Number of Pedestrians Involved</i>	1
<i>Travel Speed</i>	Unknown km/hr	<i>Travel Speed Source</i>	Unknown

Pedestrian Details

<i>Fatal</i>	Yes
<i>Age</i>	Unknown
<i>Sex</i>	Male
<i>BAC Pedestrian</i>	Unknown %
<i>Action</i>	Walking
<i>Movement</i>	Crossing the road
<i>Side Impacted</i>	Left side to vehicle

Driver Details

<i>Age</i>	Unknown
<i>Sex</i>	Unknown
<i>BAC Driver</i>	Unknown %
<i>Driving Experience</i>	Unknown years
<i>Licence Type</i>	Unknown
<i>Driver Action</i>	Unknown

Impact Vehicle Details

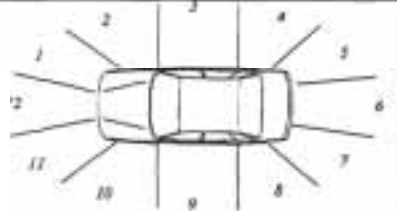
<i>Vehicle Model</i>	Mazda 323	<i>Impact Point</i> 1	
<i>Type</i>	Car		
<i>Number Involved</i>	1		
<i>Modifications</i>	None		

Road Site Details

<i>Traffic Control of Area</i>	Traffic signal at intersection	<i>Road Type</i>	Arterial
<i>Traffic Conditions</i>	Moderate	<i>Road Alignment</i>	Straight
<i>Weather Conditions</i>	Fine , dry road	<i>Natural Lighting</i>	Night
<i>Number of Lanes</i>	2	<i>Street Lighting</i>	Street lights
<i>Road Division</i>	Line		

ite Diagram

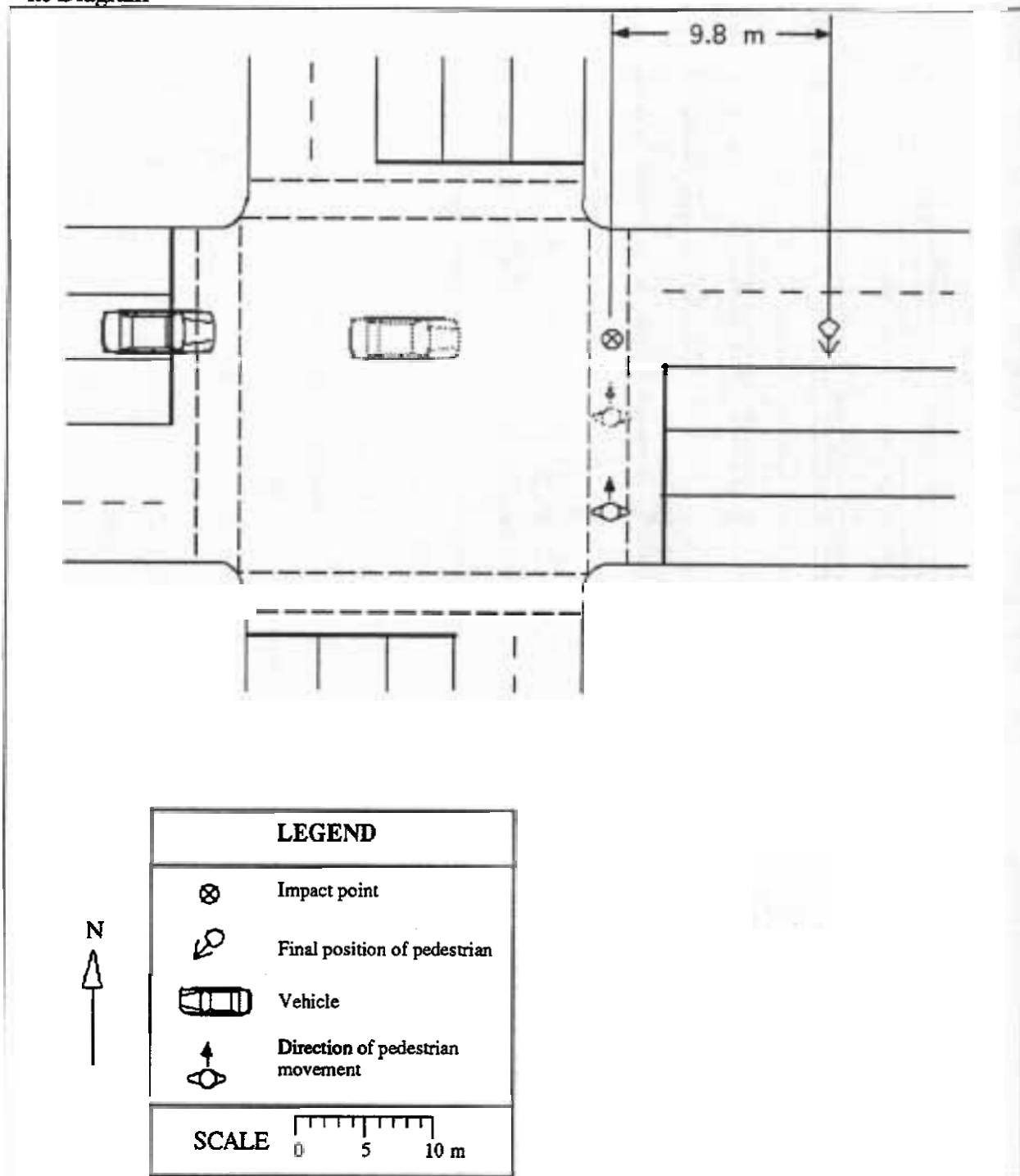

Accident Description

The vehicle was accelerating after the traffic lights at the intersection changed to green, when it struck a pedestrian who was heading west across the road. At the site, there were no marks made by the vehicle, and the final vehicle position was not indicated. The projection distance of the pedestrian from the probable point of impact was 9.7 metres.

Case Details

<i>Case Number</i>	91 - H015	<i>Case type</i>	Insufficient information
<i>Date of Accident</i>	Friday, April	<i>Time</i>	2 pm
<i>Speed Limit</i>	60 km/hr	<i>Number of Pedestrians Involved</i>	1
<i>Travel Speed</i>	50 km/hr	<i>Travel Speed Source</i>	Driver and witness

Pedestrian Details

<i>Fatal</i>	Yes
<i>Age</i>	81
<i>Sex</i>	Male
<i>BAC Pedestrian</i>	0 %
<i>Action</i>	Walking
<i>Movement</i>	Crossing the road
<i>Side Impacted</i>	Right side to vehicle

Driver Details

<i>Age</i>	Unknown
<i>Sex</i>	Unknown
<i>BAC Driver</i>	0 %
<i>Driving Experience</i>	Unknown years
<i>Licence Type</i>	Unknown
<i>Driver Action</i>	Unknown

Impact Vehicle Details

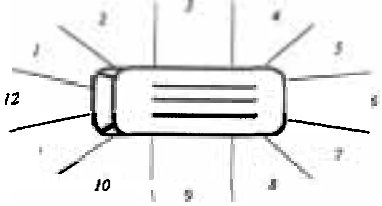
<i>Vehicle Model</i>	1981 Mitsubishi L300 van	
<i>Type</i>	Van	
<i>Number Involved</i>	1	
<i>Modifications</i>	None	
<i>Impact Point</i>	11	

Road Site Details

<i>Traffic Control of Area</i>	Traffic signal at intersection	<i>Road Type</i>	Arterial
<i>Traffic Conditions</i>	Moderate	<i>Road Alignment</i>	Straight
<i>Weather Conditions</i>	Fine , dry road	<i>Natural Lighting</i>	Day
<i>Number of Lanes</i>	2	<i>Street Lighting</i>	None
<i>Road Division</i>	Raised median strip		

ite Diagram

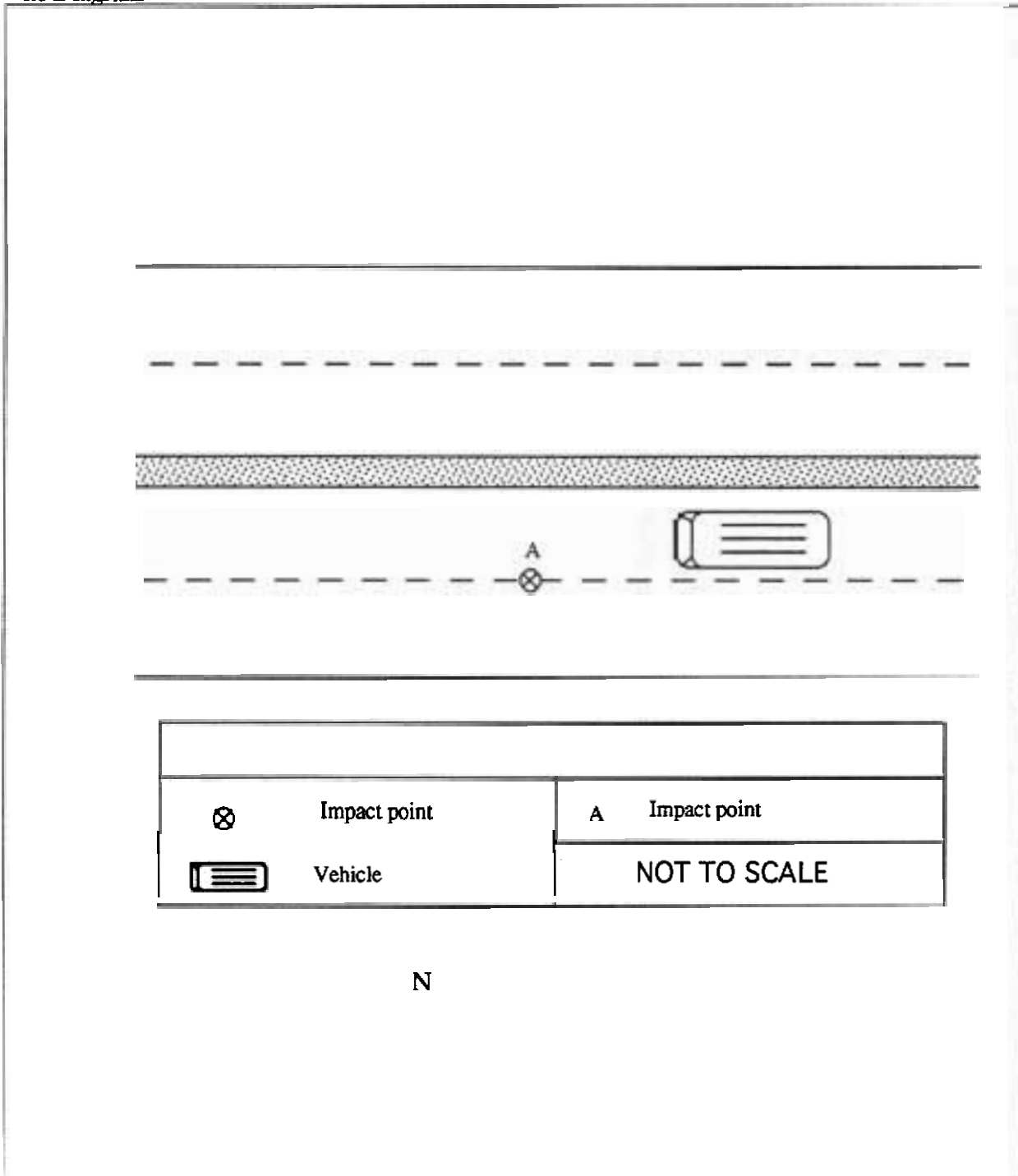

Accident Description

The pedestrian was crossing the road in an easterly direction and was hit by a van travelling north. Only the impact point was recorded in the site diagram. No driver or witness statements were available in the files.

Case Details

<i>Case Number</i>	87 - H064	<i>Case type</i>	Manoeuvre
<i>Date of Accident</i>	Tuesday, December	<i>Time</i>	9 pm
<i>Speed Limit</i>	60 km/hr	<i>Number of Pedestrians Involved</i>	1
<i>Travel Speed</i>	35 km/hr	<i>Travel Speed Source</i>	Driver

Pedestrian Details

<i>Fatal</i>	Yes
<i>Age</i>	63
<i>Sex</i>	Male
<i>BAC Pedestrian</i>	.244 %
<i>Action</i>	Other
<i>Movement</i>	Crossing the road
<i>Side Impacted</i>	Right side to vehicle

Driver Details

<i>Age</i>	23
<i>Sex</i>	Male
<i>BAC Driver</i>	0 %
<i>Driving Experience</i>	7 years
<i>Licence Type</i>	Full
<i>Driver Action</i>	No attempt made to avoid collision

Impact Vehicle Details

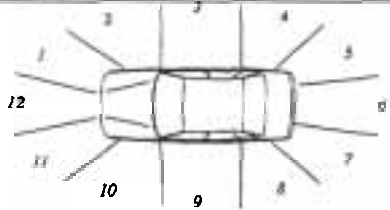
<i>Vehicle Model</i>	1977 Holden HX		
<i>Type</i>			
<i>Number Involved</i>	1		
<i>Modifications</i>	None		
		<i>Impact Point</i>	11

Road Site Details

<i>Traffic Control of Area</i>	None	<i>Road Type</i>	Arterial
<i>Traffic Conditions</i>	Light	<i>Road Alignment</i>	Straight
<i>Weather Conditions</i>	Fine , dry road	<i>Natural Lighting</i>	Night
<i>Number of Lanes</i>	1	<i>Street Lighting</i>	Street lights
<i>Road Division</i>	Raised median strip		

Site Diagram

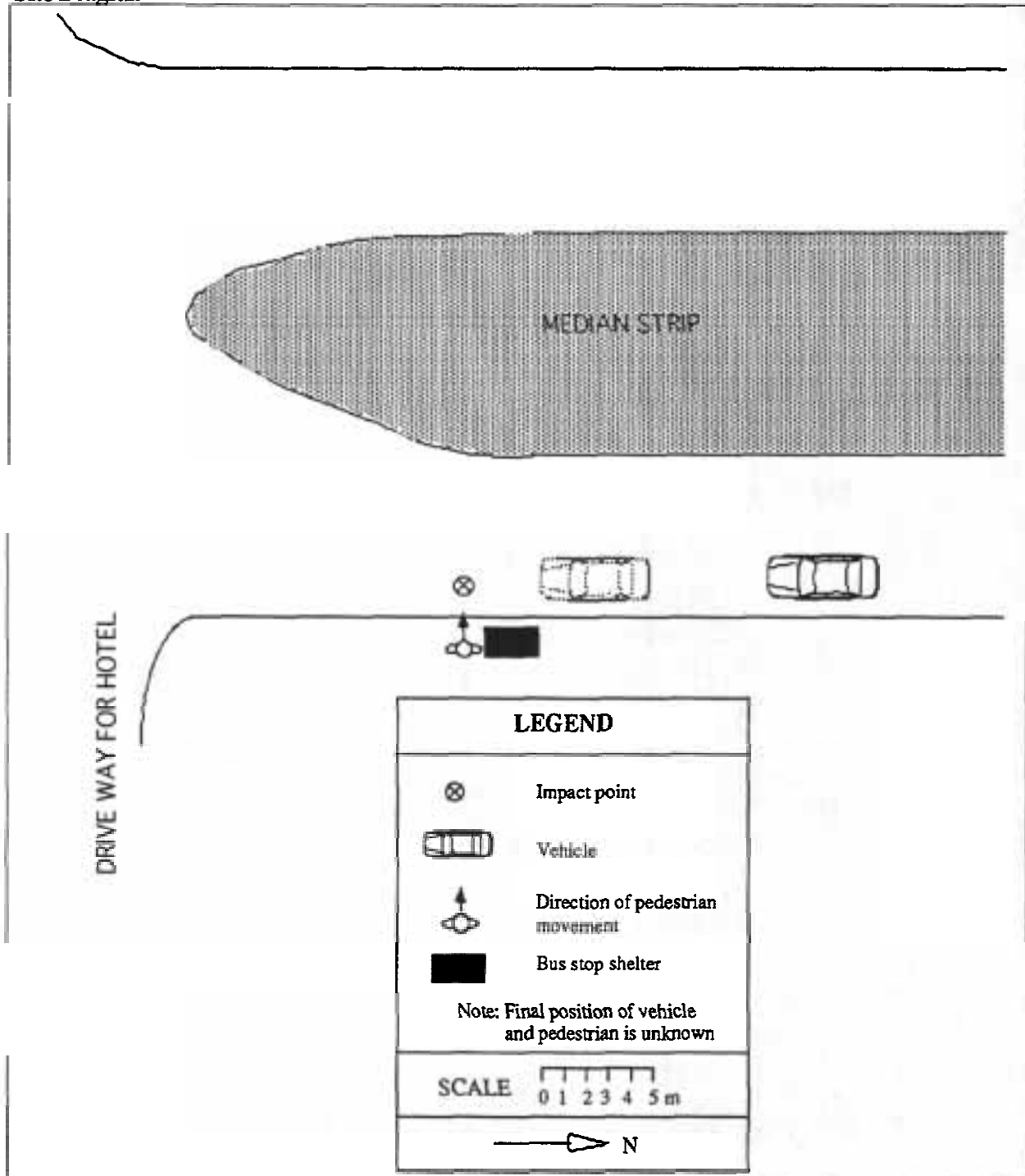

Accident Description

Pedestrian was standing on the eastern footpath and fell forward onto the roadway and into the path of a south bound vehicle. The driver stated that he was slowing down to 35 km/hr to turn left. His attention was drawn to a vehicle waiting to turn out of the hotel car park, when he realised he collided with something. The driver did not see the pedestrian prior to the collision. The pedestrian was hit by the front left hand side of the vehicle.



<i>Fatal</i>	Yes	<i>Age</i>	Unknown
<i>Age</i>	67	<i>Sex</i>	Unknown
<i>Sex</i>	Male	<i>BAC Driver</i>	Unknown %
<i>BAC Pedestrian</i>	Unknown %	<i>Driving Experience</i>	Unknown years
<i>Action</i>	Unknown	<i>Licence Type</i>	Unknown
<i>Movement</i>	Unknown	<i>Driver Action</i>	Unknown
<i>Side Impacted</i>	Unknown		

Impact Vehicle Details

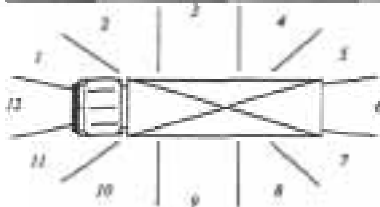
<i>Vehicle Model</i>	Unknown	<i>Impact Point</i>	
<i>Type</i>	Truck		
<i>Number Involved</i>	1		
<i>Modifications</i>	Unknown		

Road Site Details

<i>Traffic Control of Area</i>	Unknown	<i>Road Type</i>	Local street
<i>Traffic Conditions</i>	Unknown	<i>Road Alignment</i>	Unknown
<i>Weather Conditions</i>	Unknown	<i>Natural Lighting</i>	Day
<i>Number of Lanes</i>	Unknown	<i>Street Lighting</i>	Unknown
<i>Road Division</i>	Unknown		

Accident Description

The pedestrian committed suicide by diving under the wheels of a passing fuel tanker. The driver of the fuel tanker stated that he did not see anyone move towards the fuel tanker and did not realise that an impact had occurred.

Case Details

<i>Case Number</i>	85 - H019	<i>Case type</i>	Insufficient information
<i>Date of Accident</i>	Thursday, April	<i>Time</i>	1 am
<i>Speed Limit</i>	80 km/hr	<i>Number of Pedestrians Involved</i>	1
<i>Travel Speed</i>	Unknown km/hr	<i>Travel Speed Source</i>	Unknown

Pedestrian Details

<i>Fatal</i>	Yes
<i>Age</i>	24
<i>Sex</i>	Male
<i>BAC Pedestrian</i>	Unknown %
<i>Action</i>	Unknown
<i>Movement</i>	Unknown
<i>Side Impacted</i>	Unknown

Driver Details

<i>Age</i>	Unknown
<i>Sex</i>	Unknown
<i>BAC Driver</i>	Unknown %
<i>Driving Experience</i>	Unknown years
<i>Licence Type</i>	Unknown
<i>Driver Action</i>	Unknown

Impact Vehicle Details

<i>Vehicle Model</i>	Unknown	<i>Impact Point</i>	
<i>Type</i>	Multi purpose vehicle		
<i>Number Involved</i>	1		
<i>Modifications</i>	Unknown		

Road Site Details

<i>Traffic Control of Area</i>	Unknown	<i>Road Type</i>	Arterial
<i>Traffic Conditions</i>	Unknown	<i>Road Alignment</i>	Straight
<i>Weather Conditions</i>	Unknown	<i>Natural Lighting</i>	Night
<i>Number of Lanes</i>	2	<i>Street Lighting</i>	Unknown
<i>Road Division</i>	Raised median strip		

Accident Description

Hit - Run Case. No vehicle information, but it is believed to be a 4WD. It was presumed the pedestrian was walking in a northerly direction and was involved in a collision with a vehicle which resulted in his death. The pedestrian's behaviour strongly suggests that he acted in an irrational and dangerous manner. There is insufficient evidence to suggest any culpably negligent manner of driving prior to the accident. Site diagram shows skid marks and final body position. No impact point could be located. Vehicle travel speed is unknown.

Case Details

<i>Case Number</i>	85 - H024	<i>Case type</i>	Self induced
<i>Date of Accident</i>	Sunday, May	<i>Time</i>	3 am
<i>Speed Limit</i>	60 km/hr	<i>Number of Pedestrians Involved</i>	1
<i>Travel Speed</i>	Unknown km/hr	<i>Travel Speed Source</i>	Unknown

Pedestrian Details

<i>Fatal</i>	Yes
<i>Age</i>	25
<i>Sex</i>	Male
<i>BAC Pedestrian</i>	.119 %
<i>Action</i>	Standing
<i>Movement</i>	Other
<i>Side Impacted</i>	Facing vehicle

Driver Details

<i>Age</i>	Not applicable
<i>Sex</i>	Not applicable
<i>BAC Driver</i>	0 %
<i>Driving Experience</i>	Unknown years
<i>Licence Type</i>	Not applicable
<i>Driver Action</i>	Not applicable

Impact Vehicle Details

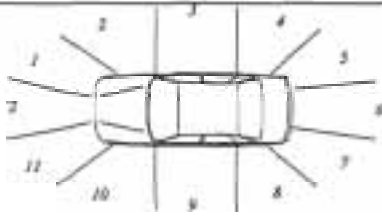
<i>Vehicle Model</i>	1971 Chrysler sedan	<i>Impact Point</i>	
<i>Type</i>	Car		
<i>Number Involved</i>	1		
<i>Modifications</i>	None		

Road Site Details

<i>Traffic Control of Area</i>	None	<i>Road Type</i>	Local street
<i>Traffic Conditions</i>	Unknown	<i>Road Alignment</i>	Straight
<i>Weather Conditions</i>	Unknown	<i>Natural Lighting</i>	Night
<i>Number of Lanes</i>	Unknown	<i>Street Lighting</i>	Unknown
<i>Road Division</i>	None		

Accident Description

The driver of the car had short circuited the starter relay of his vehicle. The driver got out of the vehicle and raised the bonnet and attempted to start the vehicle, but it was in 'Drive' position and the vehicle moved forward knocking the driver to the ground and colliding with a parked vehicle. The driver was pinned under the front left wheel and died of asphyxiation. .

Case Details

<i>Case Number</i>	86 - H078	<i>Case type</i>	Off road
<i>Date of Accident</i>	Sunday, November	<i>Time</i>	5 am
<i>Speed Limit</i>	80 km/hr	<i>Number of Pedestrians Involved</i>	1
<i>Travel Speed</i>	Unknown km/hr	<i>Travel Speed Source</i>	Unknown

Pedestrian Details

<i>Fatal</i>	Yes
<i>Age</i>	21
<i>Sex</i>	Female
<i>BAC Pedestrian</i>	.115 %
<i>Action</i>	Walking
<i>Movement</i>	Following the road
<i>Side Impacted</i>	Back to vehicle

Driver Details

<i>Age</i>	Unknown
<i>Sex</i>	Unknown
<i>BAC Driver</i>	Unknown %
<i>Driving Experience</i>	Unknown years
<i>Licence Type</i>	Unknown
<i>Driver Action</i>	No attempt made to avoid collision

Impact Vehicle Details

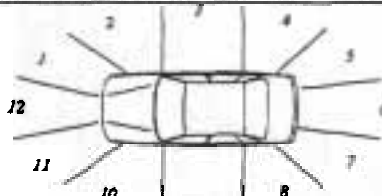
<i>Vehicle Model</i>	1970 Holden Prima	
<i>Type</i>	Car	
<i>Number Involved</i>	1	
<i>Modifications</i>	None	
<i>Impact Point</i>	11	

Road Site Details

<i>Traffic Control of Area</i>	None	<i>Road Type</i>	Arterial
<i>Traffic Conditions</i>	Unknown	<i>Road Alignment</i>	Straight
<i>Weather Conditions</i>	Unknown	<i>Natural Lighting</i>	Night
<i>Number of Lanes</i>	Unknown	<i>Street Lighting</i>	Street lights
<i>Road Division</i>	Unknown		

Accident Description

The pedestrian was thought to be walking along the carriageway and hit from behind by unknown vehicle which failed to stop. No other information was available.

Case Details

<i>Case Number</i>	88 - H017	<i>Case type</i>	Manoeuvre
<i>Date of Accident</i>	Saturday, May	<i>Time</i>	4 pm
<i>Speed Limit</i>	60 km/hr	<i>Number of Pedestrians Involved</i>	1
<i>Travel Speed</i>	70 km/hr	<i>Travel Speed Source</i>	Witness

Pedestrian Details

<i>Fatal</i>	Yes
<i>Age</i>	79
<i>Sex</i>	Male
<i>BAC Pedestrian</i>	Unknown %
<i>Action</i>	Walking
<i>Movement</i>	Crossing the road
<i>Side Impacted</i>	Left side to vehicle

Driver Details

<i>Age</i>	24
<i>Sex</i>	Male
<i>BAC Driver</i>	Unknown %
<i>Driving Experience</i>	7 years
<i>Licence Type</i>	Full
<i>Driver Action</i>	Unknown

Impact Vehicle Details

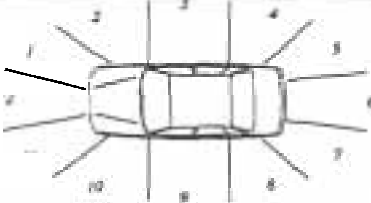
<i>Vehicle Model</i>	1975 Chrysler Centura	
<i>Type</i>	Car	
<i>Number Involved</i>	1	
<i>Modifications</i>	None	
<i>Impact Point</i>	11	

Road Site Details

<i>Traffic Control of Area</i>	Traffic signal at intersection	<i>Road Type</i>	Arterial
<i>Traffic Conditions</i>	Moderate	<i>Road Alignment</i>	Unknown
<i>Weather Conditions</i>	Fine , dry road	<i>Natural Lighting</i>	Day
<i>Number of Lanes</i>	2	<i>Street Lighting</i>	Not applicable
<i>Road Division</i>	Raised median strip		

Accident Description

The vehicle was travelling north as he was approaching an intersection with the lights on red. The driver moved into the bus lane and slowed down. Before the car had stopped the lights went green and he accelerated past the stationary cars to about 40 km/hr when he collided with a pedestrian crossing in a westerly direction.

Case Details

<i>Case Number</i>	88 - H019	<i>Case type</i>	Self induced
<i>Date of Accident</i>	Wednesday, June	<i>Time</i>	2 pm
<i>Speed Limit</i>	60 km/hr	<i>Number of Pedestrians Involved</i>	1
<i>Travel Speed</i>	60 km/hr	<i>Travel Speed Source</i>	Driver

Pedestrian Details

<i>Fatal</i>	Yes
<i>Age</i>	41
<i>Sex</i>	Male
<i>BAC Pedestrian</i>	.106 %
<i>Action</i>	Lying
<i>Movement</i>	Other
<i>Side Impacted</i>	Facing vehicle

Driver Details

<i>Age</i>	Unknown
<i>Sex</i>	Male
<i>BAC Driver</i>	0 %
<i>Driving Experience</i>	Unknown years
<i>Licence Type</i>	Unknown
<i>Driver Action</i>	Braked before impact

Impact Vehicle Details

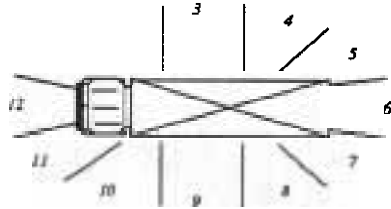
<i>Vehicle Model</i>	1983 Ford Light Truck	<i>Impact Point</i> 12	
<i>Type</i>	Truck		
<i>Number Involved</i>	1		
<i>Modifications</i>	None		
<i>Modifications</i>	None		

Road Site Details

<i>Traffic Control of Area</i>	None	<i>Road Type</i>	Arterial
<i>Traffic Conditions</i>	Moderate	<i>Road Alignment</i>	Straight
<i>Weather Conditions</i>	Fine , dry road	<i>Natural Lighting</i>	Day
<i>Number of Lanes</i>	3	<i>Street Lighting</i>	Not applicable
<i>Road Division</i>	Raised median strip		

Accident Description

The vehicle (a truck) was travelling south in the left hand lane on a two lane road for south bound traffic at about 60 km/hr. The driver stated that he saw the pedestrian standing to the rear of a parked vehicle on the left side of the road. The pedestrian was looking in the drivers direction. When the vehicle was about 6 to 7 metres from the pedestrian, he stepped onto the road and lay across the lane in front of the truck. The driver had no time to take evasive action except to brake hard. The driver estimates the impact speed to be about 50 km/hr.

Case Details

<i>Case Number</i>	88 - H030	<i>Case type</i>	Insufficient information
<i>Date of Accident</i>	Friday, August	<i>Time</i>	6 am
<i>Speed Limit</i>	80 km/hr	<i>Number of Pedestrians Involved</i>	1
<i>Travel Speed</i>	80 km/hr	<i>Travel Speed Source</i>	Police

Pedestrian Details

<i>Fatal</i>	Yes
<i>Age</i>	33
<i>Sex</i>	Male
<i>BAC Pedestrian</i>	0 %
<i>Action</i>	Walking
<i>Movement</i>	Crossing the road
<i>Side Impacted</i>	Left side to vehicle

Driver Details

<i>Age</i>	43
<i>Sex</i>	Male
<i>BAC Driver</i>	0 %
<i>Driving Experience</i>	27 years
<i>Licence Type</i>	Full
<i>Driver Action</i>	Brake after impact

Impact Vehicle Details

<i>Vehicle Model</i>	1983 Holden Commodore	
<i>Type</i>	Car	<i>Impact Point</i> 11
<i>Number Involved</i>	1	
<i>Modifications</i>	None	

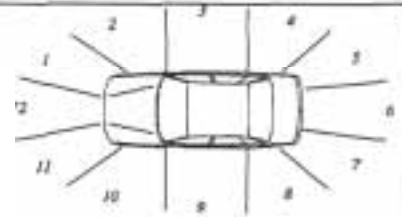

Road Site Details

<i>Traffic Control of Area</i>	Traffic signal at intersection		
<i>Traffic Conditions</i>	Light	<i>Road Type</i>	Arterial
<i>Weather Conditions</i>	Fine , dry road	<i>Road Alignment</i>	Straight
<i>Number of Lanes</i>	4	<i>Natural Lighting</i>	Day
<i>Road Division</i>	Raised median strip	<i>Street Lighting</i>	Not applicable

Accident Description

The case vehicle was travelling north at 80 km/hr in the left lane and collided with a pedestrian at the intersection. The pedestrian was crossing the road against the pedestrian lights from east to west. The driver's statement could not be found but from a witness' statement the vehicle appeared to brake heavily after impact. The witness also stated that the pedestrian left the median strip when the vehicle was about 200 metres away. The pedestrian was struck by the left hand side of the car. On impact the pedestrian was thrown into the air in the same direction as the vehicle and hit a 'KEEP LEFT' sign on the other road at the intersection. The vehicle stopped about 40 metres north of the intersection.

Case Details

<i>Case Number</i>	88 - H032	<i>Case type</i>	Insufficient information
<i>Date of Accident</i>	Friday, August	<i>Time</i>	12 pm
<i>Speed Limit</i>	60 km/hr	<i>Number of Pedestrians Involved</i>	1
<i>Travel Speed</i>	Unknown km/hr	<i>Travel Speed Source</i>	Unknown

Pedestrian Details

<i>Fatal</i>	Yes
<i>Age</i>	23
<i>Sex</i>	Female
<i>BAC Pedestrian</i>	Unknown %
<i>Action</i>	Running
<i>Movement</i>	Crossing the road
<i>Side Impacted</i>	Unknown

Driver Details

<i>Age</i>	Unknown
<i>Sex</i>	Unknown
<i>BAC Driver</i>	Unknown %
<i>Driving Experience</i>	Unknown years
<i>Licence Type</i>	Unknown
<i>Driver Action</i>	Unknown

Impact Vehicle Details

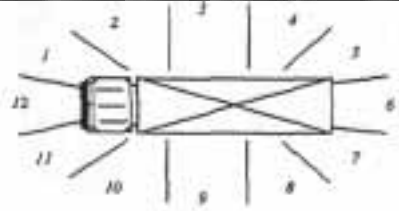
<i>Vehicle Model</i>	Toyota Dyna Truck	<i>Impact Point</i> 11	
<i>Type</i>	Truck		
<i>Number Involved</i>	1		
<i>Modifications</i>	None		

Road Site Details

<i>Traffic Control of Area</i>	None	<i>Road Type</i>	Arterial
<i>Traffic Conditions</i>	Moderate	<i>Road Alignment</i>	Straight
<i>Weather Conditions</i>	Unknown	<i>Natural Lighting</i>	Day
<i>Number of Lanes</i>	Unknown	<i>Street Lighting</i>	None
<i>Road Division</i>	Unknown		

Accident Description

The vehicle was travelling north at about 70 km/hr. The pedestrian was running back and forth across the road and ran into the path of the truck. No more information is available.

Case Details

<i>Case Number</i>	89 - H016	<i>Case type</i>	Manoeuvre
<i>Date of Accident</i>	Thursday, March	<i>Time</i>	8 pm
<i>Speed Limit</i>	60 km/hr	<i>Number of Pedestrians Involved</i>	1
<i>Travel Speed</i>	Unknown km/hr	<i>Travel Speed Source</i>	Unknown

Pedestrian Details

<i>Fatal</i>	Yes
<i>Age</i>	63
<i>Sex</i>	Male
<i>BAC Pedestrian</i>	Unknown %
<i>Action</i>	Unknown
<i>Movement</i>	Unknown
<i>Side Impacted</i>	Unknown

Driver Details

<i>Age</i>	Unknown
<i>Sex</i>	Unknown
<i>BAC Driver</i>	Unknown %
<i>Driving Experience</i>	Unknown years
<i>Licence Type</i>	Unknown
<i>Driver Action</i>	Unknown

Impact Vehicle Details

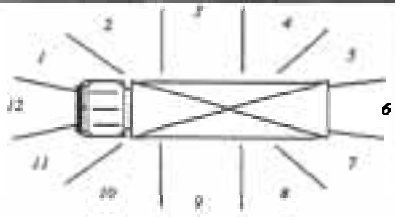
<i>Vehicle Model</i>	Tow Truck	<i>Impact Point</i> N/A	
<i>Type</i>	Truck		
<i>Number Involved</i>	1		
<i>Modifications</i>	Unknown		

Road Site Details

<i>Traffic Control of Area</i>	Unknown	<i>Road Type</i>	Local street
<i>Traffic Conditions</i>	Not applicable	<i>Road Alignment</i>	Not applicable
<i>Weather Conditions</i>	Unknown	<i>Natural Lighting</i>	Night
<i>Number of Lanes</i>	Not applicable	<i>Street Lighting</i>	Unknown
<i>Road Division</i>	Unknown		

Accident Description

The pedestrian was struck by a tow-truck in a car-park. This was a hit run accident and the vehicle involved has not been located. The pedestrian was walking home through the car park. A tow-truck in the car park reversed out, striking the pedestrian and dragging him a distance of approximately 8 m. The initial impact speed of the truck when it struck the pedestrian is likely to have been very low.

Case Details

<i>Case Number</i>	89 - H030	<i>Case type</i>	Manoeuvre
<i>Date of Accident</i>	Thursday, August	<i>Time</i>	7 pm
<i>Speed Limit</i>	60 km/hr	<i>Number of Pedestrians Involved</i>	1
<i>Travel Speed</i>	30 km/hr	<i>Travel Speed Source</i>	Driver and witness

Pedestrian Details

<i>Fatal</i>	Yes
<i>Age</i>	18
<i>Sex</i>	Male
<i>BAC Pedestrian</i>	.254 %
<i>Action</i>	Lying
<i>Movement</i>	None
<i>Side Impacted</i>	Unknown

Driver Details

<i>Age</i>	Unknown
<i>Sex</i>	Unknown
<i>BAC Driver</i>	0 %
<i>Driving Experience</i>	Unknown years
<i>Licence Type</i>	Unknown
<i>Driver Action</i>	Brake, unknown if before or after impact

Impact Vehicle Details

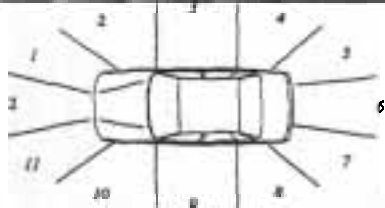
<i>Vehicle Model</i>	1983 Mitsubishi Colt	<i>Impact Point</i> 1	
<i>Type</i>	Car		
<i>Number Involved</i>	1		
<i>Modifications</i>	None		

Road Site Details

<i>Traffic Control of Area</i>	None	<i>Road Type</i>	Local street
<i>Traffic Conditions</i>	Light	<i>Road Alignment</i>	Straight
<i>Weather Conditions</i>	Fine, dry road	<i>Natural Lighting</i>	Night
<i>Number of Lanes</i>	2	<i>Street Lighting</i>	Street lights
<i>Road Division</i>	Painted median strip		

Accident Description

The pedestrian was lying on the road. He was run over by a vehicle that had just turned right and was travelling at 30 km/hr and still accelerating.

Case Details

<i>Case Number</i>	89 - H037	<i>Case type</i>	Insufficient information
<i>Date of Accident</i>	Tuesday, October	<i>Time</i>	7 am
<i>Speed Limit</i>	60 km/hr	<i>Number of Pedestrians Involved</i>	1
<i>Travel Speed</i>	Unknown km/hr	<i>Travel Speed Source</i>	Unknown

Pedestrian Details

<i>Fatal</i>	Yes
<i>Age</i>	20
<i>Sex</i>	Male
<i>BAC Pedestrian</i>	Unknown %
<i>Action</i>	Walking
<i>Movement</i>	Crossing the road
<i>Side Impacted</i>	Right side to vehicle

Driver Details

<i>Age</i>	Unknown
<i>Sex</i>	Unknown
<i>BAC Driver</i>	Unknown %
<i>Driving Experience</i>	Unknown years
<i>Licence Type</i>	Unknown
<i>Driver Action</i>	Unknown

Impact Vehicle Details

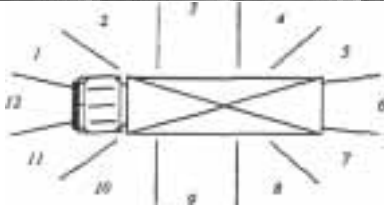
<i>Vehicle Model</i>	Mercedes 1424 Truck	
<i>Type</i>	Truck	
<i>Number Involved</i>	1	
<i>Modifications</i>	Bull Bar	
<i>Impact Point</i>	11	

Road Site Details

<i>Traffic Control of Area</i>	None	<i>Road Type</i>	Arterial
<i>Traffic Conditions</i>	Moderate	<i>Road Alignment</i>	Straight
<i>Weather Conditions</i>	Fine , dry road	<i>Natural Lighting</i>	Day
<i>Number of Lanes</i>	Unknown	<i>Street Lighting</i>	Not applicable
<i>Road Division</i>	Unknown		

Accident Description

The pedestrian was wearing a walk man, stepped into the path of a semi-trailer, and was hit on his right side. No other information available.

Case Details

<i>Case Number</i>	90 - H031	<i>Case type</i>	Driver unconscious
<i>Date of Accident</i>	Sunday, September	<i>Time</i>	10 am
<i>Speed Limit</i>	60 km/hr	<i>Number of Pedestrians Involved</i>	1
<i>Travel Speed</i>	60 km/hr	<i>Travel Speed Source</i>	Witness

Pedestrian Details

<i>Fatal</i>	Yes
<i>Age</i>	40
<i>Sex</i>	Male
<i>BAC Pedestrian</i>	0 %
<i>Action</i>	Walking
<i>Movement</i>	Following the road
<i>Side Impacted</i>	Unknown

Driver Details

<i>Age</i>	Unknown
<i>Sex</i>	Unknown
<i>BAC Driver</i>	0 %
<i>Driving Experience</i>	Unknown years
<i>Licence Type</i>	Unknown
<i>Driver Action</i>	No attempt made to avoid collision

Impact Vehicle Details

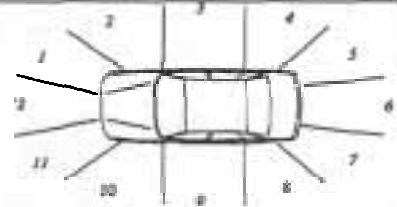
<i>Vehicle Model</i>	Holden Monaro	<i>Impact Point</i> 11	
<i>Type</i>	Car		
<i>Number Involved</i>	1		
<i>Modifications</i>	None		

Road Site Details

<i>Traffic Control of Area</i>	None	<i>Road Type</i>	Arterial
<i>Traffic Conditions</i>	Moderate	<i>Road Alignment</i>	Straight
<i>Weather Conditions</i>	Fine , dry road	<i>Natural Lighting</i>	Day
<i>Number of Lanes</i>	1	<i>Street Lighting</i>	None
<i>Road Division</i>	None		

Accident Description

The driver of the vehicle blacked out and the car veered across the road. It mounted the footpath, collided with a fence, utility pole another car and a pedestrian.

Index

<p>Groups by Location</p> <p style="padding-left: 20px;">Arterial Roads</p> <p style="padding-left: 40px;"><i>All cases except those indexed under Local streets and Other main traffic routes.</i></p> <p style="padding-left: 20px;">Local Streets</p>	<p>89 - H001 205</p> <p>89 - H035 227</p> <p>91 - H025 261</p>	<p>85 - H012 55</p> <p>85 - H020 61</p> <p>85 - H022 65</p> <p>85 - H023 67</p> <p>85 - H034 75</p> <p>85 - H038 79</p> <p>85 - H045 81</p> <p>86 - H023 99</p> <p>86 - H025 101</p> <p>87 - H046 171</p> <p>88 - H010 183</p> <p>88 - H016 189</p>
<p style="padding-left: 20px;">84 - H045 29</p> <p style="padding-left: 20px;">84 - H054 41</p> <p style="padding-left: 20px;">85 - H008 339</p> <p style="padding-left: 20px;">85 - H018 59</p> <p style="padding-left: 20px;">85 - H024 341</p> <p style="padding-left: 20px;">85 - H032 73</p> <p style="padding-left: 20px;">85 - H050 83</p> <p style="padding-left: 20px;">85 - H073 91</p> <p style="padding-left: 20px;">86 - H006 93</p> <p style="padding-left: 20px;">86 - H016 95</p> <p style="padding-left: 20px;">86 - H021 97</p> <p style="padding-left: 20px;">86 - H029 105</p> <p style="padding-left: 20px;">86 - H030 107</p> <p style="padding-left: 20px;">86 - H049 123</p> <p style="padding-left: 20px;">86 - H050 125</p> <p style="padding-left: 20px;">86 - H057 129</p> <p style="padding-left: 20px;">87 - H018 297</p> <p style="padding-left: 20px;">87 - H025 161</p> <p style="padding-left: 20px;">87 - H035 165</p> <p style="padding-left: 20px;">88 - H026 311</p> <p style="padding-left: 20px;">89 - H002 207</p> <p style="padding-left: 20px;">89 - H016 347</p> <p style="padding-left: 20px;">89 - H030 348</p> <p style="padding-left: 20px;">89 - H033 219</p> <p style="padding-left: 20px;">89 - H041 229</p> <p style="padding-left: 20px;">90 - H014 237</p>	<p>Groups by Speed Zone</p> <p style="padding-left: 20px;">60 km/hr zone accidents</p> <p style="padding-left: 40px;"><i>All cases except those indexed under 80 km/hr and 110 km/hr.</i></p> <p style="padding-left: 20px;">80 km/hr zone cases</p>	<p>85 - H019 341</p> <p>85 - H043 267</p> <p>86 - H037 113</p> <p>86 - H054 127</p> <p>86 - H069 137</p> <p>86 - H078 343</p> <p>86 - H086 145</p> <p>87 - H012 157</p> <p>88 - H012 185</p> <p>88 - H030 346</p> <p>88 - H035 197</p> <p>88 - H040 201</p> <p>88 - H048 203</p> <p>89 - H014 211</p> <p>89 - H028 323</p> <p>89 - H034 225</p> <p>90 - H012 329</p> <p>90 - H016 241</p> <p>91 - H021 255</p>
<p style="padding-left: 20px;">83 - H005 5</p> <p style="padding-left: 20px;">84 - H027 23</p> <p style="padding-left: 20px;">85 - H035 77</p> <p style="padding-left: 20px;">85 - H052 269</p> <p style="padding-left: 20px;">86 - H025 101</p> <p style="padding-left: 20px;">86 - H064 133</p> <p style="padding-left: 20px;">87 - H038 169</p> <p style="padding-left: 20px;">88 - H011 307</p> <p style="padding-left: 20px;">88 - H015 187</p>	<p style="padding-left: 20px;">110 km/hr zone cases</p> <p style="padding-left: 40px;">83 - H012 9</p> <p style="padding-left: 40px;">86 - H024 281</p> <p style="padding-left: 40px;">86 - H027 103</p>	<p>Multi-purpose vehicles</p> <p>85 - H019 340</p> <p>86 - H064 133</p> <p>88 - H015 187</p> <p>88 - H034 315</p> <p>89 - H035 227</p>
<p>Other main traffic routes</p>	<p>Groups by Vehicle Type</p> <p style="padding-left: 20px;">Buses</p> <p style="padding-left: 40px;">87 - H048 303</p> <p style="padding-left: 20px;">Cars and Car derivatives</p> <p style="padding-left: 40px;"><i>All cases except those indexed under Buses</i></p> <p style="padding-left: 40px;"><i>Motorcycles, Multi-Purpose vehicles, Trucks and, Vans and Forward Control</i></p> <p style="padding-left: 40px;"><i>Passenger Vehicles.</i></p> <p style="padding-left: 20px;">Motorcycles</p>	<p>Trucks</p> <p>84 - H005 277</p> <p>84 - H012 13</p> <p>85 - H008 339</p> <p>87 - H054 305</p> <p>88 - H019 344</p> <p>88 - H032 346</p> <p>89 - H016 347</p> <p>89 - H037 349</p> <p>90 - H029 331</p>
<p style="padding-left: 20px;">85 - H005 7</p> <p style="padding-left: 20px;">85 - H026 379</p> <p style="padding-left: 20px;">85 - H051 85</p> <p style="padding-left: 20px;">86 - H086 145</p> <p style="padding-left: 20px;">88 - H048 203</p> <p style="padding-left: 20px;">90 - H010 235</p> <p style="padding-left: 20px;">91 - H015 335</p> <p style="padding-left: 20px;">91 - H021 255</p>	<p style="padding-left: 20px;">85 - H005 49</p>	<p>Vans and Forward Control Passenger Vehicles</p>