

s47F

From: s47F
Sent: Tuesday, 24 September 2019 3:52 PM
To: s47F
Subject: RE: CDG0938 - Woolgoolga Whale Trail - additional information
 [SEC=UNCLASSIFIED]

Hi s47F

The main new pathway is a total of around 490m long plus smaller paths to lookouts. It will be constructed from a mix of concrete with some sections of elevated boardwalk through physically and environmentally challenging sections.

s22

Council are prepared to cover any cost overruns incurred by the project.

Please find below a revised cost estimate to address ineligible project management fees and to equal grant funding sought.

Item	Cost (\$)
Demolition	16680
Site establishment	42434
Construction	523974
Viewing Platforms	38478
Roadworks	52540
Carpark works	181838
Contingency	244056
TOTAL	1,100,000

Please advise if you require any further information.

Regards

s47F

Open Space and Buildings Asset Strategist | Strategic Asset Management | Coffs Harbour City Council

s47F

W: www.coffsharbour.nsw.gov.au



This email (including any attachments) is intended only for the use of the individual or entity named above and may contain information that is confidential, proprietary or privileged. If you are not the intended recipient, please notify Council immediately by return email and then delete the email, destroy any printed copy and do not disclose or use the information in it. Coffs Harbour City Council advises that this email and any attached files should be scanned to detect viruses and accepts no liability for loss or damage (whether caused by negligence or not) resulting from the use of any attached files.

From: s47F
Sent: Friday, 20 September 2019 9:33 AM
To: s47F
Subject: CDG0938 - Woolgoolga Whale Trail - additional information [SEC=UNCLASSIFIED]

Hi s47F

I have now moved onto Council's Woolgoolga Whale Trail project and had a few follow up question for this one.

Items for Clarification

- Could you please confirm how long the new pathway(trail) will be and what is will be constructed from;
- s22
- Q26 – Could you please confirm that Council are prepared to meet any cost overruns for the project should they occur.
- Q29 – Budget Table – Cost estimates. In your application you have provide a *Cost Estimates* document (attachment 5) which provides detailed costing for the project. For the purposes of my assessment, I have summarised this into some simplified cost items below, however s22 - out of scope you have included a **“Project Management”** cost item for an amount of \$75,751.62. Based on the CDG Guidelines (item 2.2), *CDG funding will not be provided for ongoing operational and maintenance costs or existing staff member salaries of the funding proponent organisation.* As the Project Management cost fall into this definition of ineligible items, I suggest we amend the budget table below. Also the *Cost Estimates* document (attachment 5) final total was \$1,100,522.65 which is s47G than the total CDG grant amount (by \$522.65). As you have stated that the project is funded 100% by the CDG grant, could you please ensure that any amendment to the figures either:
 - total the CDG grant of \$1,100,000; or
 - could you please provide confirmation that Council is contributing funding to cover any amount above the \$1,100,000.

Item	Cost (\$)
Demolition	15,532.70
Site establishment	40,000.00
Construction	487,908.48
Viewing Platforms	35,829.86
Roadworks	48,923.54
Carpark works	169,321.60
Contingency	227,254.85
Project Management (ineligible item)	75,751.62
Total (needs to total \$1.1m or provide confirmation of Council's financial commitment for any amount above the CDG grant of \$1.1m)	1,100,522.65

Could you please provide your response as soon as possible to assist me in completing my assessment. If you have any questions please do not hesitate to ask, I'm more than happy to help.

Kind regards

s47F

Contract Manager | Community Development Grants Programme
Regional Programs | Regional Development & Local Government
Department of Infrastructure, Transport, Cities and Regional Development
GPO Box 594, Canberra ACT 2601

t s47F

| w www.infrastructure.gov.au

From: s47F

Sent: Wednesday, 18 September 2019 4:01 PM

To: CDG <CDG@infrastructure.gov.au>

Subject: Woolgoolga Whale Trail CDG Request for Information Your Ref MC19-000505

Please refer to attached completed RFI documentation and attachments for the Community Development Grant committed by Kevin Hogan MP, Federal Member for Page, for the Woolgoolga Whale Trail. Please advise if you require any further information.

Regards

s47F

Open Space and Buildings Asset Strategist | Strategic Asset Management | Coffs Harbour City Council

s47F

| W: www.coffsharbour.nsw.gov.au



This email (including any attachments) is intended only for the use of the individual or entity named above and may contain information that is confidential, proprietary or privileged. If you are not the intended recipient, please notify Council immediately by return email and then delete the email, destroy any printed copy and do not disclose or use the information in it. Coffs Harbour City Council advises that this email and any attached files should be scanned to detect viruses and accepts no liability for loss or damage (whether caused by negligence or not) resulting from the use of any attached files.

Scanned by **MailMarshal** - Marshal8e6's comprehensive email content security solution. Download a free evaluation of MailMarshal at www.marshall.com

This email (including any attachments) is intended only for the use of the individual or entity named above and may contain information that is confidential, proprietary or privileged. If you are not the intended recipient, please notify Council immediately by return email and then delete the email, destroy any printed copy and do not disclose or use the information in it.

Coffs Harbour City Council advises that this email and any attached files should be scanned to detect viruses and accepts no liability for loss or damage (whether caused by negligence or not) resulting from the use of any attached files.

s47F

From: s47F
Sent: Thursday, 22 July 2021 4:12 PM
To: s47F
Subject: CDG0938 [SEC=OFFICIAL]

OFFICIAL

Hi s47F

As discussed, here is the link to the project on Grant Connect. This is the website where all Federal Government Grants are required to be reported. It includes the project description that is consistent with the project approved by the Minister and supported by the activity description in the funding agreement. Any significant change to the project or project activity in the funding agreement would require Ministerial approval.

[Woolgoolga Whale Trail](#)

s22

Please don't hesitate to contact me if you have any further questions.

Kind Regards

s47F

Assistant Director • Regional Programs • Regional Development, Local Government and Regional Recovery

s47F

GPO Box 594 Canberra, ACT 2601

Department of Infrastructure, Transport, Regional Development and Communications
CONNECTING AUSTRALIANS • ENRICHING COMMUNITIES • EMPOWERING REGIONS

infrastructure.gov.au



OFFICIAL

s47F

From: s47F
Sent: Wednesday, 11 August 2021 3:58 PM
To: s47F
Subject: RE: CDG0938 [SEC=OFFICIAL] Woolgoolga Whale Trail Notice of Motion

Hi s47F

Please see the Council Notice of Motion (NOM) which was adopted on Thursday 22nd July 2021.

We are currently working to determine an appropriate course of action including timeframes, to address the resolution shown below.

The notice of motion was presented to Council following rigorous representations to elected Councillors from a section of the community in recent months. s22

[Redacted]

NOM21/16 WOOLGOOLGA WHALE TRAIL

2021/163 RESOLVED (Cr s47F / Cr s47F

That Council:

1. Write to Infrastructure Australia s22 ct at
 - 1.1 Create concept drawings of possible path alignment options and put on public display.
 - 1.2 Pending path alignment chosen undertake relevant environmental and engineering studies.
 - 1.3 Bring proposed path back to council for determination.
2. Continue with completion of broader project interfaces, where possible.

The Motion on being put to the meeting was carried unanimously.

CARRIED

The meeting adjourned for a short recess, the time being 7.09pm and reconvened at 7.17pm.

Cheers

s47F
Project Manager
Strategic Asset Management | Coffs Harbour City Council

s47F
| W: www.coffsharbour.nsw.gov.au

[Follow Us: on Twitter](#)



Proudly supporting **MyCOFFS**
shaping Coffs Harbour's future

This email (including any attachments) is intended only for the use of the individual or entity named above and may contain information that is confidential, proprietary or privileged. If you are not the intended recipient, please notify Council immediately by return email and then delete the email, destroy any printed copy and do not disclose or use the information in it.

Coffs Harbour City Council advises that this email and any attached files should be scanned to detect viruses and accepts no liability for loss or damage (whether caused by negligence or not) resulting from the use of any attached files.

From: s47F
Sent: Wednesday, 11 August 2021 2:35 PM
To: s47F
Subject: FW: CDG0938 [SEC=OFFICIAL]

OFFICIAL

Hi s47F

When we spoke last week we discussed that you would follow up our discussion with an email outlining the current status of the project.

As there is considerable interest in this project, I'd appreciate it if you could email me an update as soon as possible.

Thanks.

Kind Regards

s47F

[Redacted]
Assistant Director • Regional Programs • Regional Development, Local Government and Regional Recovery

s47F
[Redacted]
GPO Box 594 Canberra, ACT 2601

Department of Infrastructure, Transport, Regional Development and Communications
CONNECTING AUSTRALIANS • ENRICHING COMMUNITIES • EMPOWERING REGIONS

infrastructure.gov.au   

s22 - irrelevant material - duplicate email trail

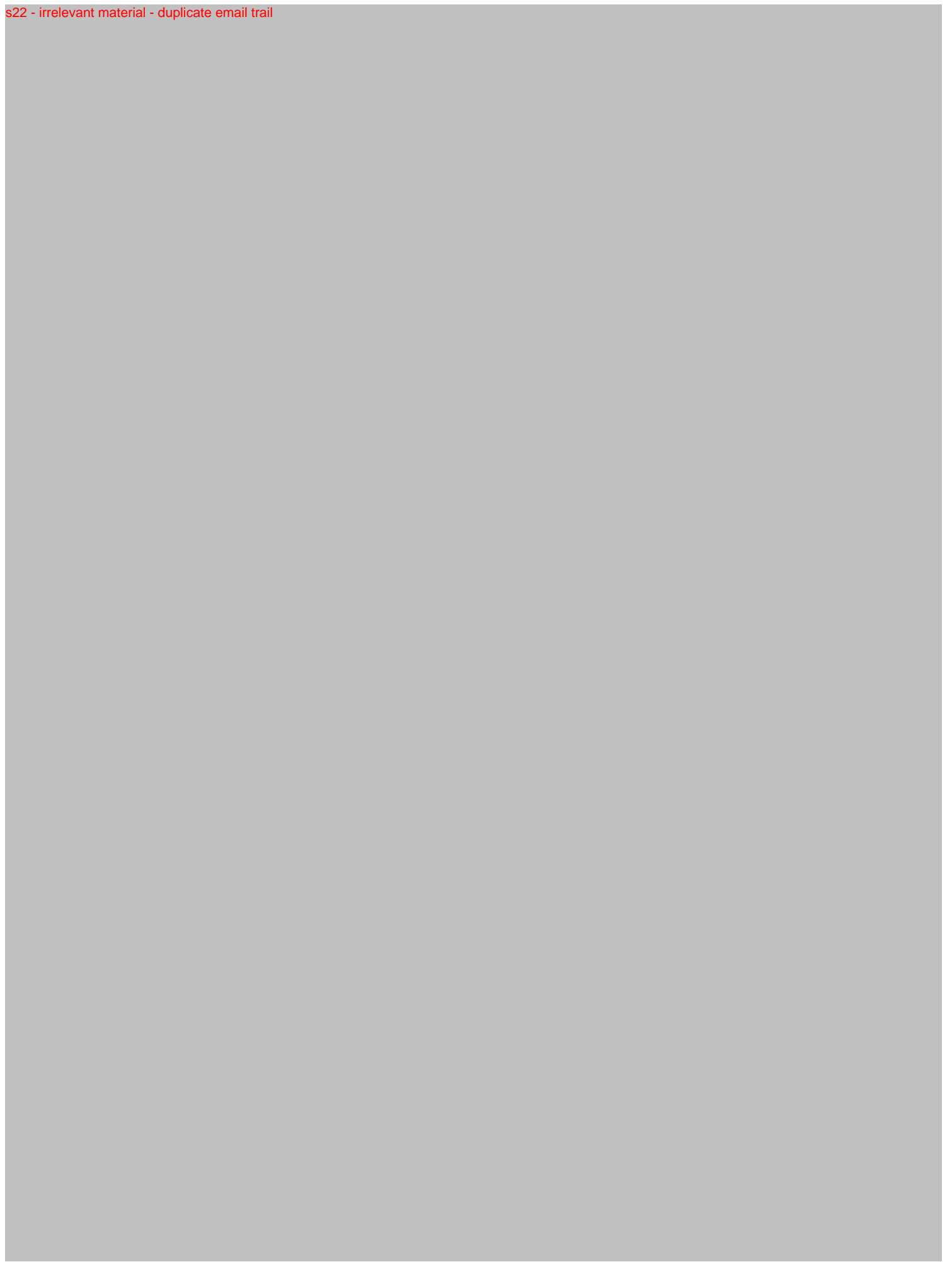



Australian Government

Department of Infrastructure, Regional Development and Cities

Request for Information

Community Development Grants Programme

Before you begin

The Department is asking for information about your project proposal so that we may commence developing a Funding Agreement should the Australian Government decide to approve funding for the project. Missing or unclear information may delay the development of the Funding Agreement.

Please note that information requested in this document may be provided to relevant Commonwealth, State and/or local government agencies, organisations and individuals, including those you identify in this proposal. The purpose of this process is to substantiate your claims and/or statements, and to verify the capacity of your organisation to manage Australian Government funds and deliver the project. It will also seek comment on the viability of the proposal and, if appropriate, identify if the proposal is eligible for funding through an alternative funding stream.

Information relating to individuals will be protected under the Privacy Act 1988. Requests for access to such information, where rejected by proponents, will be dealt with under the provisions of the Freedom of Information Act 1982.

You will need to complete Request for Information and submit with required supporting documentation to support your application.

This information enables the Department to undertake a value with relevant money assessment and provide advice to the Minister prior to an Agreement being negotiated and funding being released. The Department will contact proponents if further information is required.

Should you have any questions on how to answer any part of the Request for Information please submit your query to cdg@infrastructure.gov.au.

How do I submit my Request for Information?

Complete and submit this form and the necessary support documents via email to: cdg@infrastructure.gov.au as soon as possible.

If your response is likely to include documents that cannot be sent electronically, please submit this form and all necessary documents in hard copy to:

Community Development Grants Programme
Regional Programs Branch
Department of Infrastructure, Regional Development and Cities
GPO Box 594
CANBERRA ACT 2601

REQUEST FOR INFORMATION

Organisation Details

1. Organisation details

Legal Name	Coffs Harbour City Council	ABN	79126214487
Trading Name		ACN	
GST Status	N/A		

2. What is your Business Structure?

Local Government	X
Incorporated Association	
Sole Trader	
Partnership	
Company	
Trust – provide a copy of the trust deed	
Other, please specify	

3. Your bank account details. Provide details of the bank account where project funding will be deposited

Bank Name	s47F	
BSB		
Account Name		
Account Number		

4. Your Organisation's Physical (registered) Address

Street Address Line 1	Corner Coff and Castle Streets
Street Address Line 2	
Suburb/Town	Coffs Harbour
State/Territory	NSW
Postcode	2450
Organisational Email	Coff.council@chcc.nsw.gov.au
Organisational Website	www.coffsharbour.nsw.gov.au

5. Your Organisation's Postal Address

Postal Address Line 1	Locked Bag 155
Postal Address Line 2	
Suburb/Town	Coffs Harbour
State/Territory	NSW
Postcode	2450

6. Authorised Person Contact Details
(e.g. CEO or the person authorised to sign Deed of Agreements)

Title (eg. Mr/Mrs/Ms/Dr)	s47 F
First Name	s47F
Surname	s47F
Position	Director Sustainable Infrastructure (Acting)
Telephone	s47F (f)
Email Address	s47F

7. Project Manager Contact Details
(e.g. the person who will lead the implementation of your project)

Title (eg. Mr/Mrs/Ms/Dr)	s47 F
First Name	s47F
Surname	s47F
Position	Open Space and Buildings Asset Strategist
Telephone	(s47F (f)
Email Address	s47F
Additional Details (Relevant to the project, qualifications, experience, and professional memberships, if applicable)	Registered Landscape Architect with the Australian Institute of Landscape Architects

8. Key Personnel within the Organisation who will be involved in the project delivery, other than the authorised person or project manager

Title (eg. Mr/Mrs/Ms/Dr)	s47 F
First Name	s47F
Surname	s47F
Position	Project Leader Open Space and Buildings
Telephone	s47F (f)
Email Address	s47F
Additional Details (Relevant to the project, qualifications, experience, and professional memberships, if applicable)	

9. Within the last five (5) years, has your Organisation been subject to an event such as a Government investigation, liquidation, litigation or significant change of financial position

No	Yes
If Yes , please note which of the following events occurred and provide details below	
Government Investigation on your organisation or related entities	Standard Local Government minor litigations/ investigations not relevant to our ability to deliver this project
Litigation or liquidation proceedings	"
Significant (adverse) change of financial position not reflected in Financial statements provided	No
Any other particulars likely to adversely affect your capacity to undertake this project	No

Project Details

10. Project Title – Use the title from the confirmation of the election commitment. If proposing an alternative project title, provide reasons why.

Woolgoolga Whale Trail

11. Project location. If a street number is not known, please provide the Lot number.

Street Address Line 1	Pollack Esplanade
Street Address Line 2	
Suburb/Town	Woolgoolga
State/Territory	NSW
Postcode	2456
Longitude	153.20455 E
Latitude	30.10905 S
Federal Electorate	Page

12. Detailed Project Description (Describe in less than 150 words what the project is doing, ie construction of sport precinct including two Rugby League fields, six netball courts and amenities block including change rooms, public facilities, meeting rooms and cafeteria; upgrade of swimming pool to include new grandstand and children’s waterpark; or installation of lighting at sports field including purchase and installation of four poles and footings, 16 x 15000W MZ lights and 16 shields and upgrade of existing power supply on site.). **PROJECT BENEFITS ARE TO BE INCLUDED AT Q14 BELOW).**

This project includes the construction of a key missing link of footpath from Woolgoolga Beach Reserve to Woolgoolga Headland including 2 lookouts, upgraded car parking, seating, and shade trees.

13. If the CDG funded project is part of a larger project, please provide details below (ie CDG is funding one stage of a multi-stage project).

The Woolgoolga Whale Trail is a part of the Woolgoolga Beach Master Plan which includes upgrades to the Beach Reserve. Stage 1 is currently under construction which includes relocation of caravan park boundary, new public toilet, footpaths, furniture and new playground. The Whale Trail will provide a missing link from the Reserve to the Headland.

s22

Woolgoolga Whale Tail will offer connectivity to the existing Solitary Island Coastal Walk paths and contributes to building the profile of Coffs Coast as a destination for nature tourism. The Woolgoolga Whale Trail is a part of the Solitary Islands Walk which is a 60km walk travelling from Sawtell to Red Rock. It is considered to be the iconic indigenous culture and nature based tourism product on the Coffs Coast.

s22

s22



s22



19. Indicate the current stage of development of your proposal. Provide any supporting documents if available (i.e. concept or preliminary designs, final designs, independent cost estimates, ready to commence tender/procurement process or preferred contractor selected and contracted for the project.)

Document	Stage of development
Master Plan	Complete
Detailed Construction Documentation	In Progress
Cost Estimates	Internal civil engineer estimate complete

20. Identify and provide details of who will own the asset on completion. Where land and buildings are owned by a Third Party, have leasing arrangements been confirmed and secured? (Written evidence must be provided).

Organisation	Coffs Harbour City Council		
ABN / ACN	As above		
Street Address Line 1			
Street Address Line 2			
Suburb/Town	(w)	(m)	(f)
State/Territory			
Postcode			
Leasing arrangements			

21. Provide detail of who will manage and maintain the project after completion and who will provide the funding.

Coffs Harbour City Council

s22

Financial Details

23. What is the total project cost? (Use GST exclusive amounts) **\$1.1 million**
24. What is the amount of funding committed by the Australian Government? (Use GST exclusive amounts) **\$1.1 million**
25. Partner funding. Complete the table with details of all confirmed funding to this project, and the status of the funding.

Partner name	ABN	Amount (GST Excl)	Cash / In Kind	Received, Confirmed, To be confirmed

26. Provide details of the arrangements in place to provide for any cost overruns or funding shortfalls on your proposed project.

The budget has been carefully developed to be conservative. Project cost estimates include a generous contingency.

27. Have you completed a tender/procurement process and appointed a preferred contractor or do you have a cost estimate which has been independently developed/assessed?

Please provide details below:

Cost estimate attached developed by internal civil engineer experienced in design and delivery of walking trail projects

28. Are there any parts of the project that have already commenced?

No <input checked="" type="checkbox"/>	Yes
If Yes, please provide details below:	

29. Budget Table (this is a summary of either the contracted Budget or quantity surveyor cost estimate)

Cost Item	Description of Cost Item	Total Estimated Cost (\$) (GST exclusive)
	Refer to attached Cost Estimate by civil engineer	1,100,000

List of Cost Items

- | | |
|---|-------------------------|
| Planning / Design | Consultants/contractors |
| Construction/Fit-out | Project Management |
| Research and Development | Materials |
| Plant/Equipment Hire | Training |
| Plant/Equipment Purchase | Marketing/Promotion |
| Government Approvals | Legal/accounting |
| Operating Costs (e.g. rent, computers, etc) | Other Costs |
| Wages, salary and superannuation | |

NOTE1: Evidence of these costs are to be provided as a required supporting document (e.g. cost estimate, quotes, market comparisons, valuations, contracted cost, etc)

NOTE2: Australian Government Funding will not be provided for ongoing operation and maintenance costs or for salaries for existing staff members of the funding proponent organisation.

REQUIRED SUPPORTING INFORMATION

- Audited financial statements for the last two (2) years (only required for projects with a total project cost over \$80,000);
- Cash flow forecasts for the next five (5) years (only required for projects with a total project cost in excess of \$1.5 million for state or local government authorities or \$1 million for other organisations);
- Business Plan and/or Feasibility Study (if applicable);
- Project Management Plan (if applicable);
- Market research/community consultation (if applicable)
- Asset Operations Management Plan (if applicable);
- Confirmation of partnership funding including evidence of bank borrowings (if applicable)
- Evidence of third party leasing arrangements (if applicable)
- Designs
- Cost estimate or contracted cost

Legal Authorisation

I		<full name of Authorised Officer>
as	Director of Sustainable Infrastructure (Acting)	<position/title>
of	Coffs Harbour City Council	<organisation name>
	Locked Bag 155	<postal address> >
	Coffs Harbour, NSW 2450	

confirm that:

- I am a person authorised to make this declaration on behalf of my organisation and all relevant persons have made a full disclosure of information.
- The information provided in this form and all appended documents is complete and correct. I understand that information provided in this *Request for Information* will form the basis of the funding agreement and that giving false or misleading information is a serious offence.
- The Department of Infrastructure, Regional Development and Cities (the Department) is authorised to undertake the necessary steps to assess the proposal from my organisation by checking the information provided in this proposal, or by obtaining additional information from:
 - Departmental databases and records, including information related to previous funding provided to my organisation;
 - Other Australian Government agencies such as the Australian Taxation Office and the Australian Securities and Investments Commission;
 - State, Territory or Local Government agencies;
 - Law enforcement agencies;
 - Credit reference agencies;
 - Courts or Tribunals; and
 - Any other appropriate organisation, information source or person as reasonably required to perform background checks.
- I agree that the Department may arrange for an Independent Viability Assessment (IVA) of my project by an external adviser or consultant to the Department. Where applicable, the Department may request a yearly breakdown of costs for on-going operational and maintenance of the complete project for a minimum of five (5) years.
- To the best of my knowledge, I have disclosed (Part A Declaration of Conflict of Interest) all actual, apparent or potential conflicts of interest that would prevent my organisation from proceeding with the proposal outlined in this *Request for Information* or from entering into a Funding Agreement with the Australian Government to deliver a project which relates to this *Request for Information*.

Signed: 

Date: 18 19 19

Declaration of Conflict of Interest

Please complete either Part I or Part II of the Declaration of Conflict of Interest

Part I – No Known Conflict

I confirm that at the time of signing, to the best of my knowledge I am unaware of any actual, apparent or potential conflicts of interest that would prevent my organisation from proceeding with the proposal outlined in this *Request for Information* or from entering into a Funding Agreement with the Australian Government to deliver a project which relates to this *Request for Information*..

I undertake that if at any time I become aware that I, or any other employees or persons associated with the Coffs Harbour City Council have an actual, apparent or potential conflict of interest, then I will:

- a) immediately notify the Department of Infrastructure, Regional Development and Cities in writing of that Conflict and of the steps the Coffs Harbour City Council propose to take to resolve or otherwise deal with the Conflict;
- b) make full disclosure to the Department of Infrastructure, Regional Development and Cities of all relevant information relating to the Conflict; and
- c) take such steps as the Department of Infrastructure, Regional Development and Cities may, if they choose to, reasonably require to resolve or otherwise deal with that Conflict.

I understand that if I fail to notify the Department of any actual, apparent or potential conflicts of interest or am unable or unwilling to resolve or deal with the Conflict as required by the terms noted above, the Department of Infrastructure, Regional Development and Cities may seek to terminate any Funding Agreement established in relation to a project which relates to this *Request for Information*.



.....
(signature)

.....
(printed name)

18/9/19

.....
(date)

.....
(signature of witness)

.....
(printed name of witness)

.....
(date)

STATEMENT OF COMPLIANCE

I, [REDACTED] Director of Sustainable Infrastructure Coffs Harbour City Council make the following statement for the benefit of the Department of Infrastructure, Regional Development and Cities:

Having made diligent inquiries, I have reasonable grounds to believe the organisation itself, and staff working with children on behalf of my organisation in relation to the Department of Infrastructure, Regional Development and Cities grant activity:

- comply with relevant legislation relating to requirements for working with children in the jurisdiction in which they work; and
- have complied with relevant legislation in their jurisdictions relating to mandatory reporting or suspected child abuse and neglect as required or otherwise defined by state or territory legislation.

I undertake to ensure that all staff will continue to comply for the duration of any grant agreement Coffs Harbour City Council hold with the Department of Infrastructure, Regional Development and Cities.

s47F

Signed: ... [REDACTED]

Date: 18/9/19

 JOB No. 11111111
 DATE OF ISSUE: 01/01/2013
 AUTHORITIES: TELSTRA (Y/N)
 POWER (Y/N)
 NBN (Y/N)

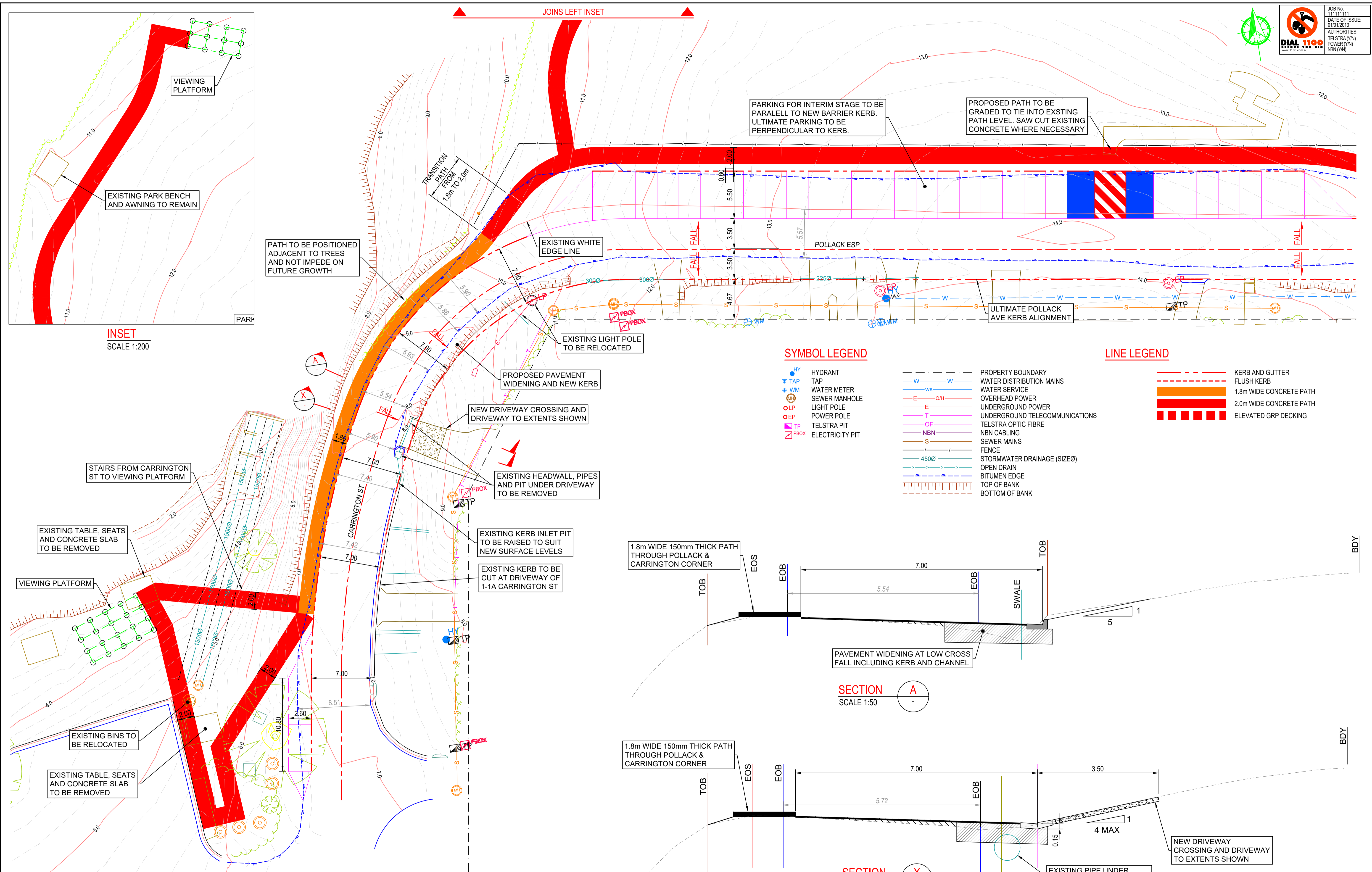

INSET SCALE 1:200

LAYOUT SCALE 1:200

SYMBOL LEGEND

- HY HYDRANT
- TAP TAP
- WM WATER METER
- SM SEWER MANHOLE
- LP LIGHT POLE
- EP POWER POLE
- TP TELSTRA PIT
- PBOX ELECTRICITY PIT

- PROPERTY BOUNDARY
- W-W WATER DISTRIBUTION MAINS
- ws WATER SERVICE
- E-OH OVERHEAD POWER
- E UNDERGROUND POWER
- T UNDERGROUND TELECOMMUNICATIONS
- TELSTRA OPTIC FIBRE
- NBN NBN CABLING
- S SEWER MAINS
- FENCE
- 4500 STORMWATER DRAINAGE (SIZEØ)
- OPEN DRAIN
- BITUMEN EDGE
- TOP OF BANK
- BOTTOM OF BANK

LINE LEGEND

- KERB AND GUTTER
- - - FLUSH KERB
- 1.8m WIDE CONCRETE PATH
- 2.0m WIDE CONCRETE PATH
- ELEVATED GRP DECKING

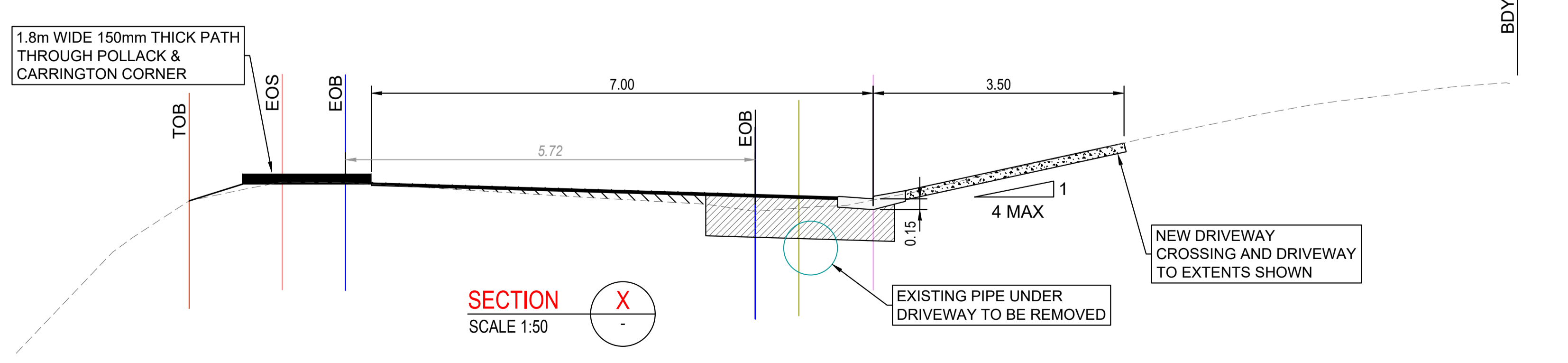
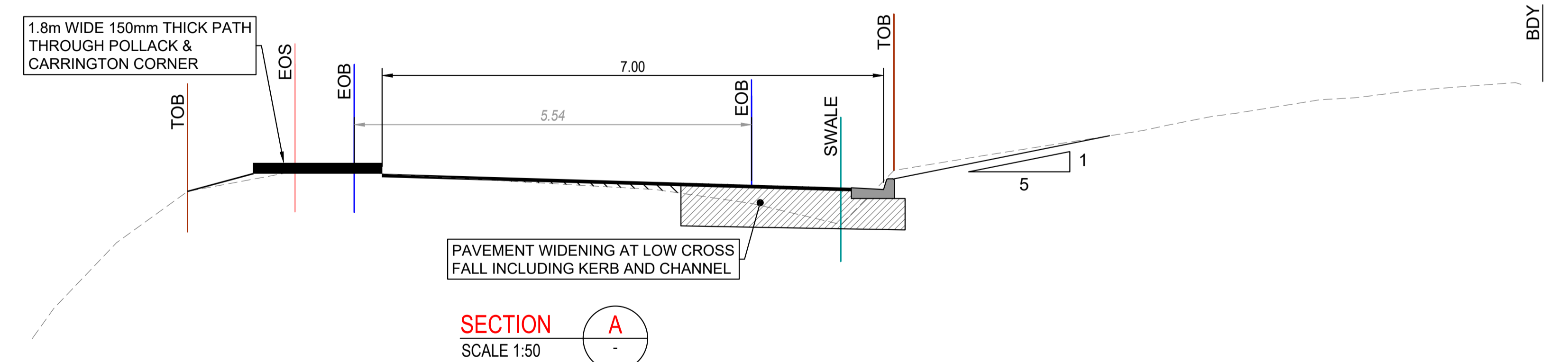

L:\Detail\Paris Gardens\2190302\Woolgoolga Whale Trail\CAD\CONCEPT.dwg

(C) COPYRIGHT
 The design and details shown on these drawings are applicable to this project only and may not be reproduced in whole or in part or be used for any other project or purpose without the consent of COFFS HARBOUR CITY COUNCIL, with whom copyright resides.

Datum: A.H.D			
Grid: GDA94(MGA)			
Origin: SSM			
Reference Plans:			
A ISSUED FOR COMMENT	DDDD	DDMMYY	
Rev.	Amendments	Apprd.	Date

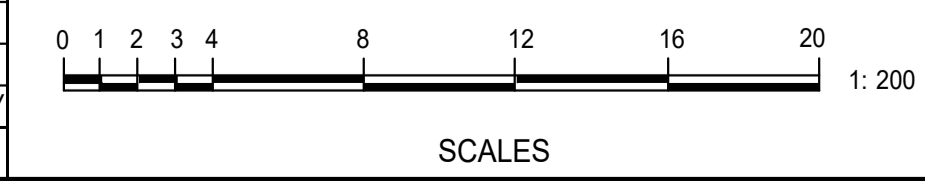

Survey	MAY 2019	SIGNED APPROVALS ON ORIGINAL
Designed	MAY 2019	Section Leader
Drawn	MAY 2019	
Checked		
Issue	PRELIMINARY	Drawing Status: Unless there is an approved signature hereon, this plan is not for construction.
Project Code	PN#	



COFFS HARBOUR CITY COUNCIL
 STRATEGIC ASSET MANAGEMENT
 Locked Bag 155
 Coffs Harbour NSW 2450
 Ph (02)66484000 Fax (02)66484477
 www.coffsharbour.nsw.gov.au
 coffs.council@chcc.nsw.gov.au

WOOLGOOLGA WHALE TRAIL
POLLACK CORNER
CONCEPT OPTION 01
PLAN AND SECTION

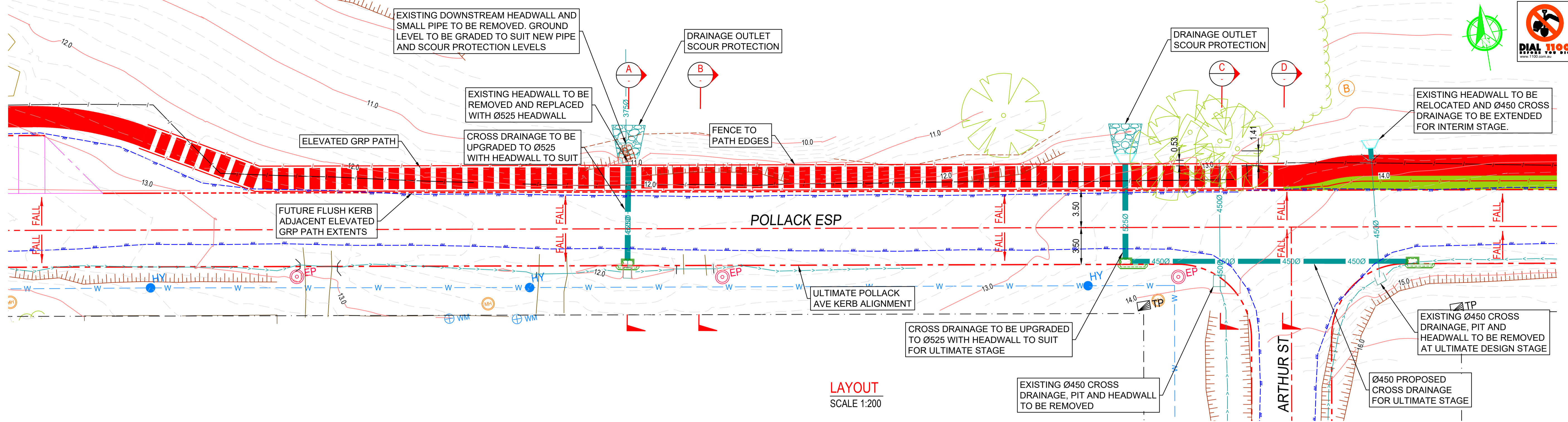
Council Plan No. 2190302
 Sheet 1 of NNN
 Original Size Revision A1 A

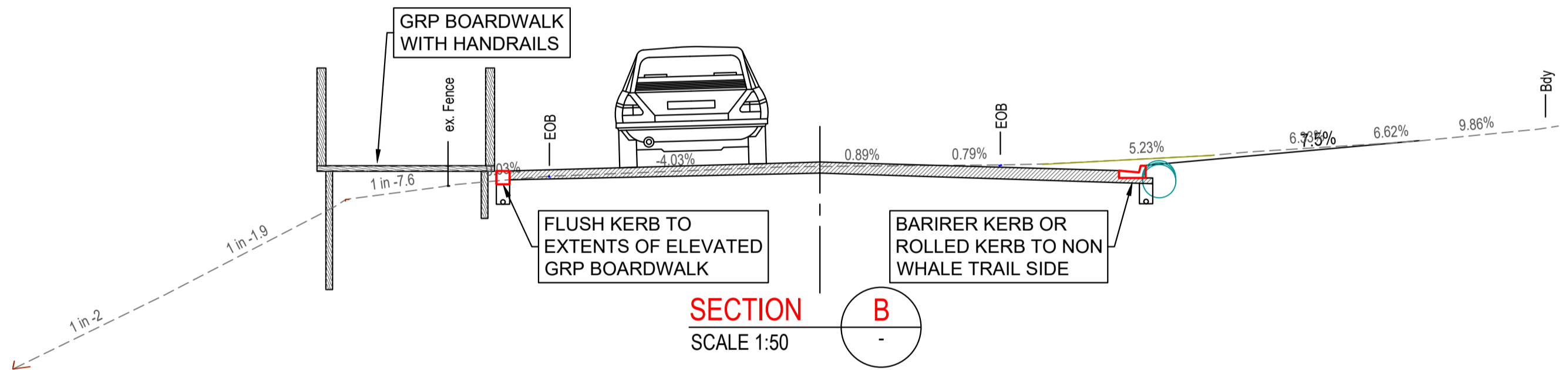

LAYOUT
 SCALE 1:200



SECTION B
 SCALE 1:50

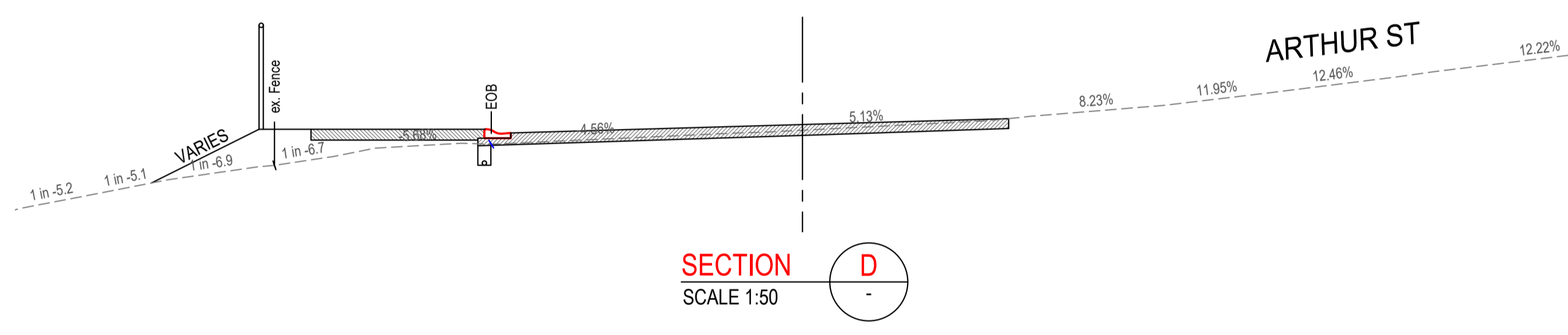

SECTION D
 SCALE 1:50

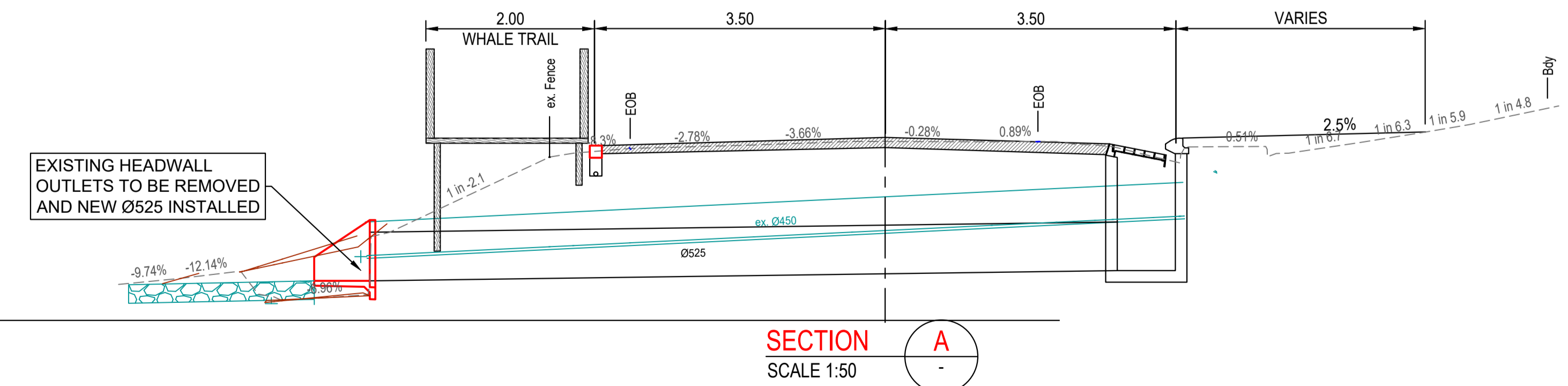

SECTION A
 SCALE 1:50

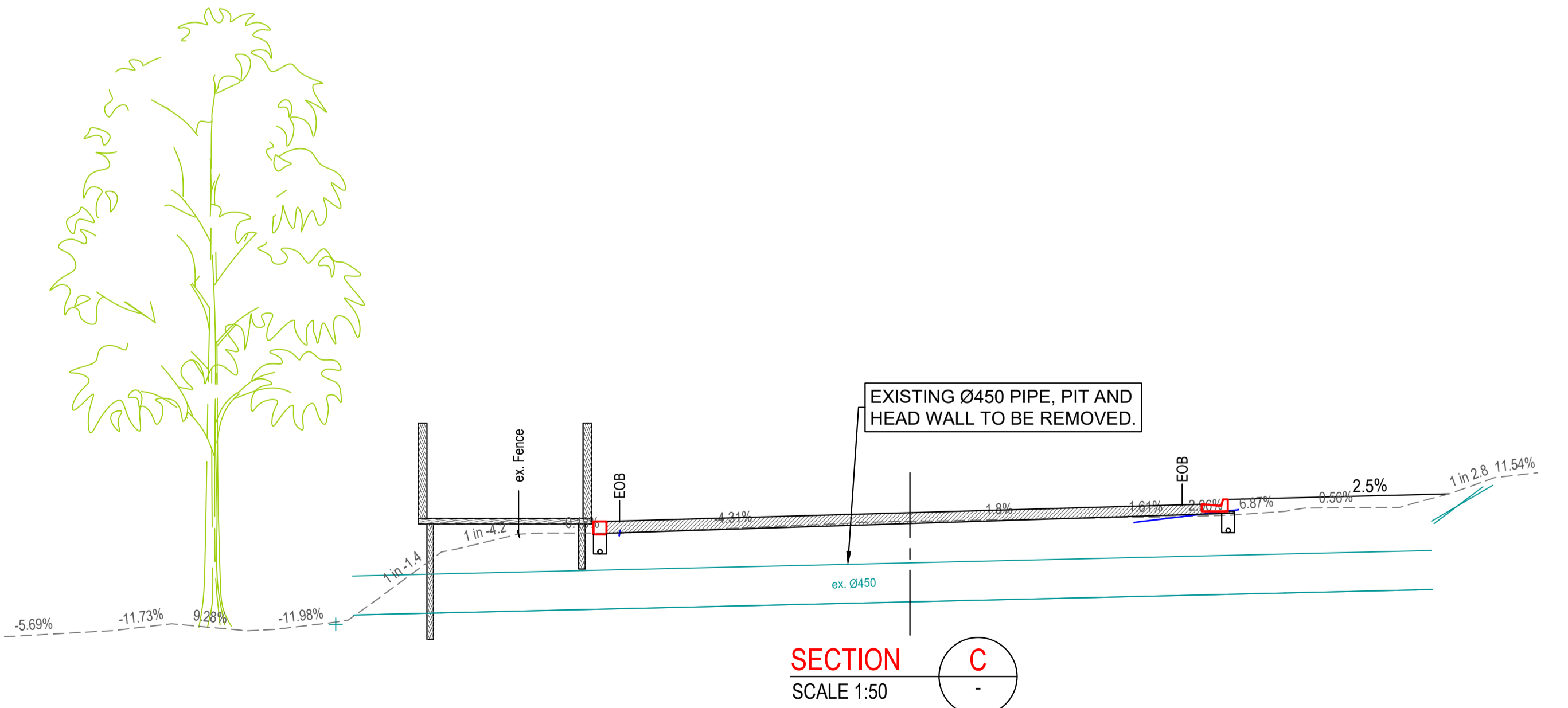

SECTION C
 SCALE 1:50

L:\Detail\Peris\Concepts\2190302\Woolgoolga Whale Trail\CAD\CONCEPT.dwg

(C) COPYRIGHT
 The design and details shown on these drawings are applicable to this project only and may not be reproduced in whole or in part or be used for any other project or purpose without the consent of COFFS HARBOUR CITY COUNCIL with whom copyright resides

Datum: A.H.D	
Grid: GDA94(MGA)	
Origin: SSM	
Reference Plans:	
A ISSUED FOR COMMENT	DDDD DDMMYY
Rev.	Amendments Apprd. Date

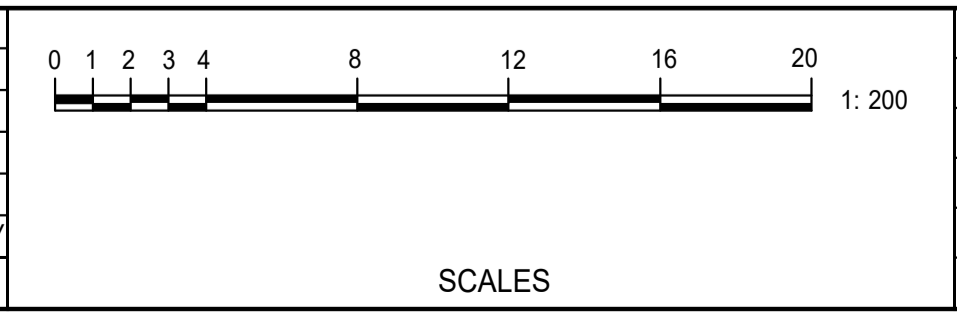

Survey	MAY 2019	SIGNED APPROVALS ON ORIGINAL
Designed	MAY 2019	Section Leader
Drawn	MAY 2019	
Checked		
Issue	PRELIMINARY	Drawing Status: Unless there is an approved signature hereon, this plan is not for construction.
Project Code	PN#	

COFFS HARBOUR CITY COUNCIL
 STRATEGIC ASSET MANAGEMENT
 Locked Bag 155
 Coffs Harbour NSW 2450
 Ph (02)66484000 Fax (02)66484477
 www.coffsharbour.nsw.gov.au
 coffs.council@chcc.nsw.gov.au

WOOLGOOLGA WHALE TRAIL
POLLACK ST CENTRAL
CONCEPT OPTION 01
PLAN AND SECTIONS

Council Plan No.	2190302
Sheet 2 of NNN	
Original Size	Revision
A1	A



JOB No: 111111111
 DATE OF ISSUE: 01/01/2013
 AUTHORITIES:
 TELSTRA (Y/N)
 POWER (Y/N)
 NBN (Y/N)

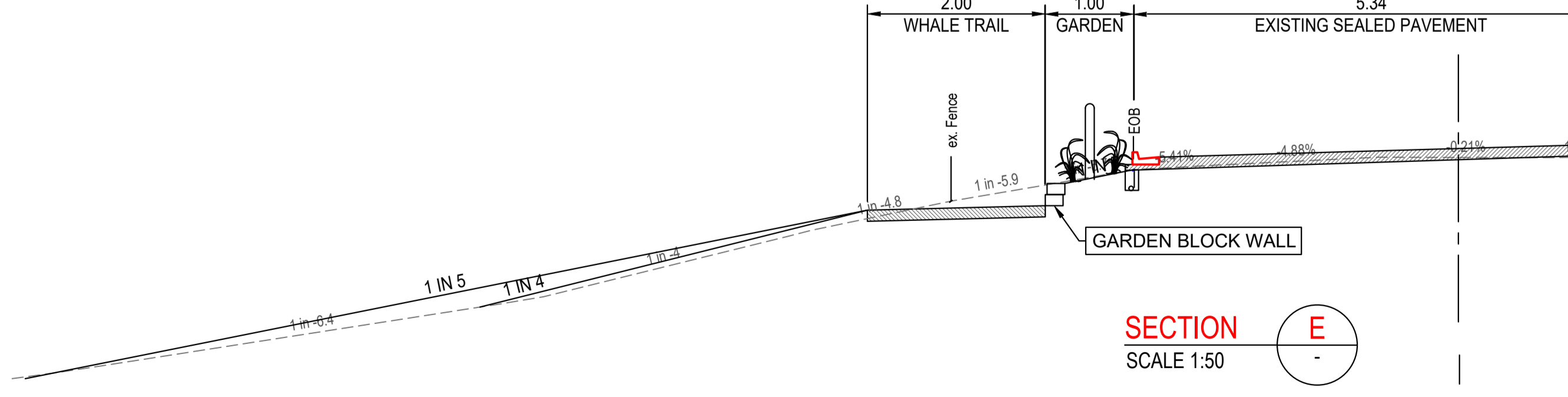
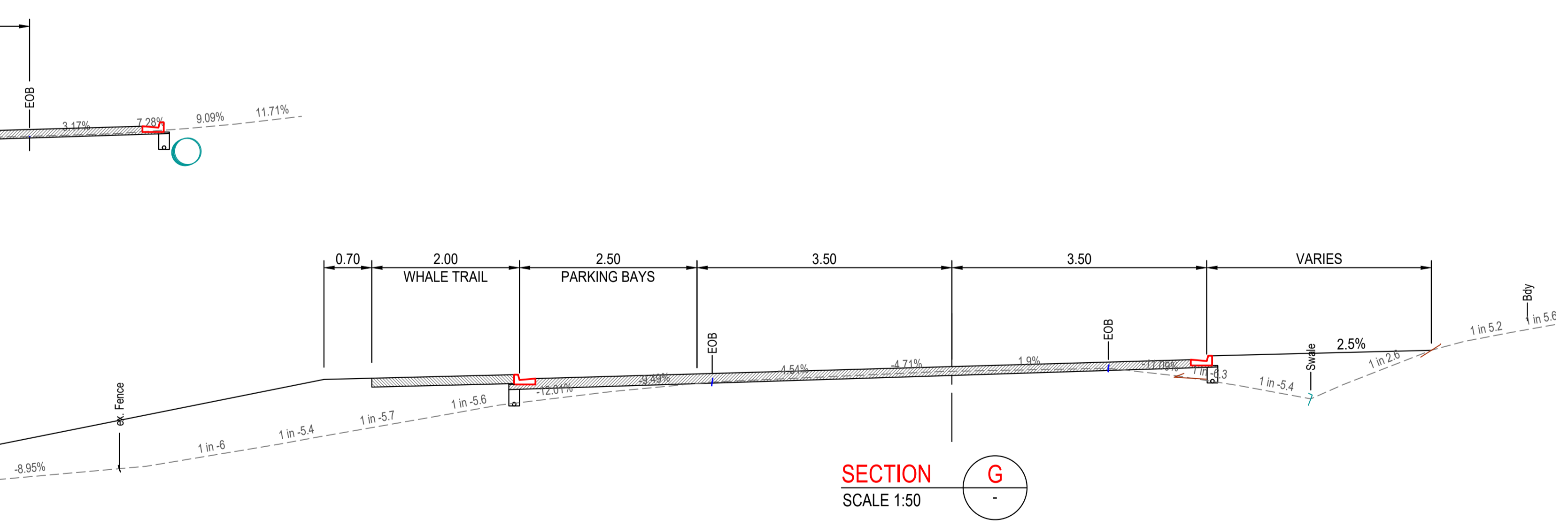
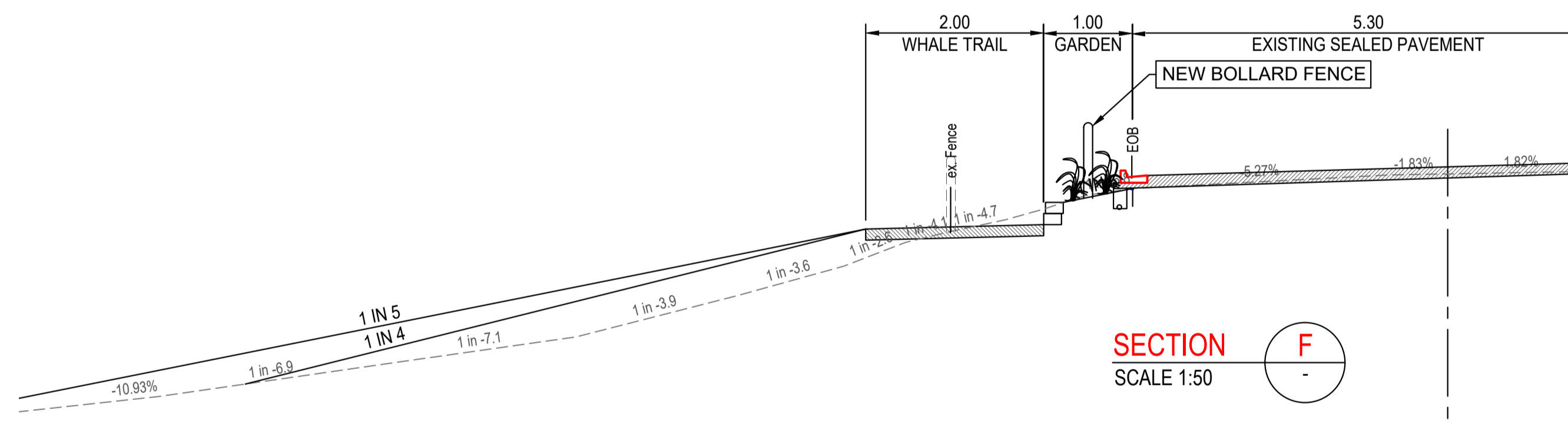
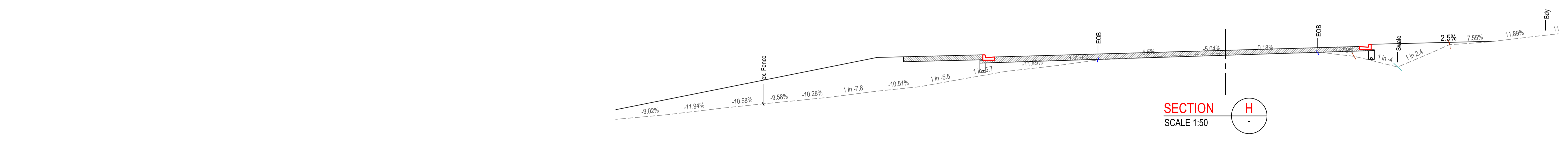
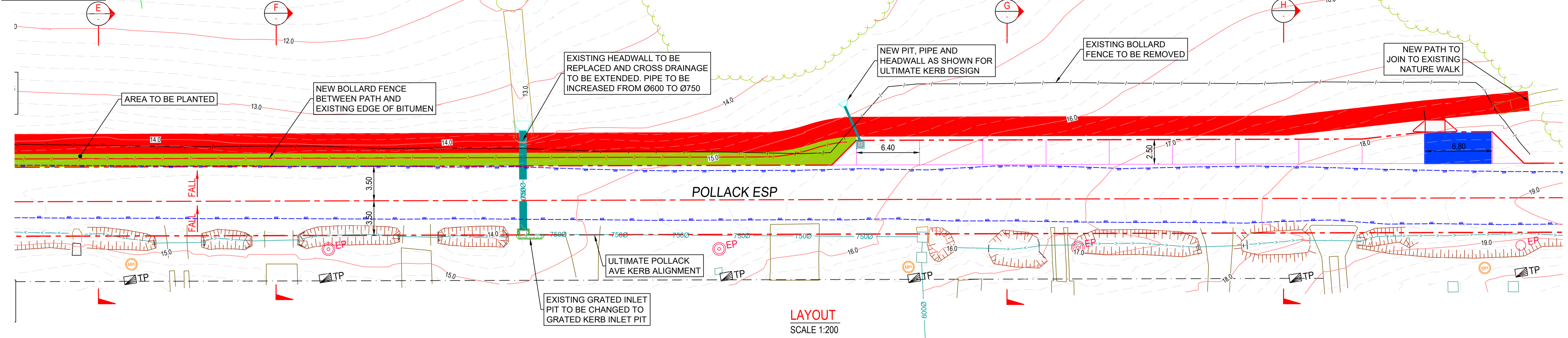
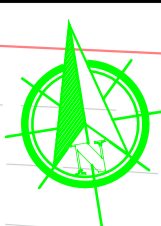

L:\Detail\Peris Gardens\2190302\Woolgoolga Whale Trail\CAD\CONCEPT.dwg

(C) COPYRIGHT
 The design and details shown on these drawings are applicable to this project only and may not be reproduced in whole or in part or be used for any other project or purpose without the consent of COFFS HARBOUR CITY COUNCIL with whom copyright resides

Datum: A.H.D			
Grid: GDA94(MGA)			
Origin: SSM			
Reference Plans:			
Rev. A	ISSUED FOR COMMENT	DDDD	DDMMYY
Rev.	Amendments	Apprd.	Date

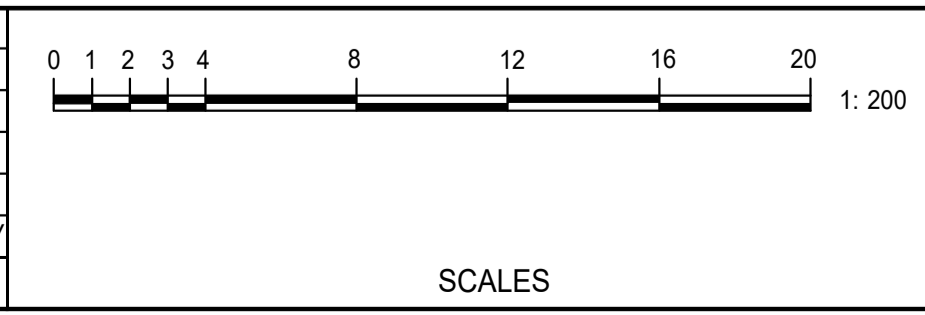

Survey	MAY 2019	SIGNED APPROVALS ON ORIGINAL
Designed	MAY 2019	Section Leader
Drawn	MAY 2019	
Checked		
Issue	PRELIMINARY	Drawing Status: Unless there is an approved signature hereon, this plan is not for construction.
Project Code	PN#	

COFFS HARBOUR CITY COUNCIL
 STRATEGIC ASSET MANAGEMENT
 Locked Bag 155
 Coffs Harbour NSW 2450
 Ph (02)66484000 Fax (02)66484477
 www.coffs Harbour.nsw.gov.au
 coffs.council@chcc.nsw.gov.au

WOOLGOOLGA WHALE TRAIL
POLLACK ST EAST
CONCEPT OPTION 01
PLAN AND SECTIONS

Council Plan No.	2190302
Sheet 3 of NNN	
Original Size	Revision
A1	A



Woolgoolga Beach Reserve

CONCEPT DESIGN REPORT

Strategic Context

The Beach Reserve

Woolgoolga Beach Reserve is highly valued by the local community and visitors, as it offers a wide range of recreational opportunities, from protected swimming to surfing, walking and boating.

The community greatly enjoys the existing low key development and nearby restaurants, cafes and markets offered at these beaches.

Role and Character

The Woolgoolga Foreshore and Beach Reserve consists of a variety of key spaces and places with a variety of roles and functions. The reserve responds to the existing coastal setting and engages the town centre.

A number of different design responses are possible depending on the future outcomes and timing of the caravan park, SLSC and Marine Rescue.

The Reserve is Woolgoolga's premier public open space and a key tourism asset. It's renewal will assist Woolgoolga in capturing new business and service opportunities supported by growing numbers of residents and visitors.

Historic Influences

The original survey of Woolgoolga was completed in 1886 and followed the colonial grid system. There has been little deviation in grid development pattern from the original survey plan in the majority of the Town Centre.

A number of influences have shaped the structure and character of the Town Centre over its history, including:

- The natural setting including the beach, sloping topography, Woolgoolga Creek and flood prone land;
- Historic land ownership patterns and port activities;
- The former role of Solitary Islands Way as the highway;
- The disparate commercial precincts as a result of changing industry bases and highway alignments; and
- The low scale and density of urban development due to the availability of property and the absence of sustained development pressures.

Contents

Strategic Context

The Beach Reserve 01

Concept Design

Beach Reserve Masterplan 03

Masterplan Detail Plans 05

Integrated Play Concept 13

Amenities Design Concept 17

Materials Palette 19

Planting Strategy 21

Planting Palettes 23

Appendix A

Strategic Context

Planning Process to Date 01

Key Informing Strategies and Initiatives 02

Site Analysis

Views and Visual Setting 03

Micro Climate 04

Natural Hazards and Flooding 05

Existing park Infrastructure 06

Movement Networks 07

What We've Heard

Amenities Analysis

The Endorsed Foreshore Park Concept Plan

The Endorsed Plan of Management

Appendix B

Woolgoolga Beach Reserve Community Consultation Summary

Appendix C

NSW NPWS Buster & Pier Timbers



Concept Design

Beach Reserve Masterplan



Dune stabilisation fence to be set back/down to enhance open views to the beach from the reserve

Secondary beach access point

Primary beach access point, including Surf Life Savers access

Boat ramp access only

Views to the headland are opened up from Beach Street by de-cluttering the central parkland.

Beach Street road section subject to the development of a People Movement and Transport Strategy



legend

- 01** Existing parking area is formalised with inclusion for disabled parking and shade trees planted on property boundaries to maintain residents views.
- 02** Shade trees are situated on property boundaries in order to maintain clear views for residents.
- 03** Existing dune vegetation is retained and enhanced with appropriate native species.
- 04** Large shade trees and open lawns provide a flexible space to inhabit.
- 05** Informal beach access for surfers, private water craft and swimmers. Illegal beach access points are to be closed and re-vegetated.
- 06** The pedestrian link between Wharf street is enhanced to provide a more legible connection to the beach.
- 07** Main access relocated to minimise conflicts with boat ramp users and direct beach goes away from the permanent rip at the southern end of the beach. New deck with shade shelter with the potential to reuse material from the SLSC. An external shower and an accessible ramp connection to beach is provided, with provision for beach mat anchor points for wheelchair access.
- 08** Re-vegetation and stabilisation of the dune with native species, including groves of Pandanas and Casuraina trees. Dune protection fence to be set back and recessed to enhance views from the reserve.
- 09** Informal lawns for quiet recreation and low planting with shade trees to maintain ocean views.
- 10** Relocated playground.
- 11** Large open turf lawn to facilitate temporary events, activation and play. Potential location for community markets and stalls.
- 12** Pockets of lawn provide picnicking opportunities adjacent the re-vegetated dunes.
- 13** A flexible space for outdoor events, temporary activation and community celebrations. Tensile shade structure incorporating suspended decorative artwork elements.
- 14** Vegetated buffer along caravan park edge.
- 15** Informal picnic lawn for use as breakout space during events.
- 16** New wayfinding, signage and artwork opportunities at parkland gateways and key nodes, with the potential to incorporate a heritage overlay.
- 17** New amenities building with a PWD WC, changing places facility, shared wash hand basins and external showers.
- 18** Deck under existing trees, surrounded by native planting.
- 19** Small informal events lawn.
- 20** Existing boat ramp is retained.
- 21** New SLSC car park with boat trailer parking and overflow area adjacent the new Surf Life Saving Club.
- 22** Surf Life Saving Club.
- 23** Relocated fish cleaning station.
- 24** Re-vegetated areas reducing the extent of grass areas to be maintained.
- 25** A new accessible deck with shade structure and viewing terraces.
- 26** Whale Trail: accessible boardwalk provides a connection between the reserve and the existing headland path. Impacts on remnant fragile vegetation to be minimised through detailed design and construction.
- 27** Existing open lawns are retained.
- 28** A new lookout deck with seating. Existing shelter to be upgraded.
- 29** Existing lookout retained.
- 30** Retain and protect existing Norfolk Island Pines.
- 31** Reconfigured Woolgoolga Beach Caravan Park, as per approved Woolgoolga Beach Reserve Plan of Management.

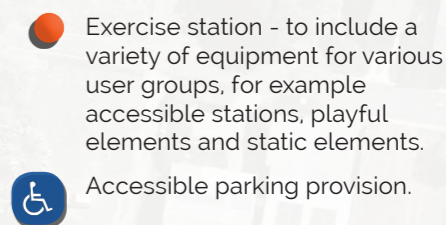

adjoins adjacent

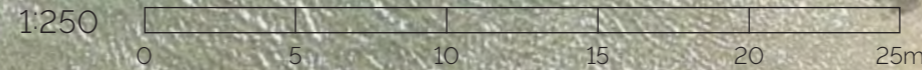

Dune stabilisation fence to be set back/down to enhance open views to the beach from the reserve

Flexible open lawns for community events



Proposed new trees to provide shade on the beach edge

Re-vegetated edge to the beach

Proposed new boardwalk to connect reserve to headland

bbq's & shade shelters

A change in materiality highlights potential conflict point

- Legend**
- 01** Large open turf lawn to facilitate temporary events, activation and play. Potential location for community markets and stalls.
 - 02** Pockets of lawn provide picnicking opportunities adjacent the re-vegetated dunes.
 - 03** New wayfinding, signage and artwork opportunities at parkland gateways and key nodes, with the potential to incorporate a heritage overlay.
 - 04** Potential market set-up, utilising the verge for stalls and creating a promenade.
 - 05** Small informal events lawn.
 - 06** Existing boat ramp is retained.
 - 07** New SLSC car park with boat trailer parking and overflow area adjacent the new Surf Life Saving Club.
 - 08** Relocated fish cleaning station.
 - 09** Re-vegetation and stabilisation of the dune with native species, including groves of Pandanas trees.
 - 10** A new accessible deck with shade structure and viewing terraces.
 - 11** New accessible boardwalk provides a legible connection between the reserve and the existing headland path.
 -  Exercise station - to include a variety of equipment for various user groups, for example accessible stations, playful elements and static elements.
 -  Accessible parking provision.



Artists impression of the proposed headland lookout shelter & pathway improvement works





Proposed shelter to provide protection from sun & wind

Open lawns

Proposed new boardwalk to connect reserve to headland

Legend

- 01** Re-vegetated areas reducing the extent of grass areas to be maintained.
- 02** New accessible floating deck provides a legible connection between the reserve and the existing headland path.
- 03** Existing open lawns are retained.
- 04** A new lookout deck with seating. Existing shelter to be upgraded.
- 05** Existing lookout retained.
- 06** Parking on Pollack Esplanade is formalised, with shade trees planted on property boundaries to maintain residents views.
- 07** Additional seating provided along Pollack Esplanade within the reserve, capitalising on ocean views, as well as near the proposed exercise node.
- 08** Existing shelter to be retained and upgraded.
-  Exercise station - to include a variety of equipment for various user groups, for example accessible stations, playful elements and static elements.
-  Accessible parking provision.

1:250

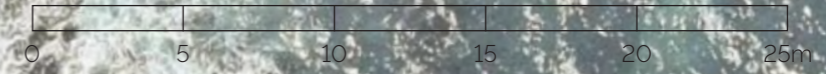

01

07

03

07

01

01

07

03

Pollack Esplanade

Proposed new concrete footpath to connect reserve to headland





The Hon Michael McCormack MP

Deputy Prime Minister
Minister for Infrastructure, Transport and Regional Development
Leader of The Nationals
Federal Member for Riverina

Ref: MC19-000505

Councillor Denise Knight
Mayor
Coffs Harbour City Council
Locked Bag 155
COFFS HARBOUR NSW 2450

15 MAR 2019

Dear Mayor

I am writing to confirm the Australian Government's commitment to provide up to:

- \$1.1 million for the Woolgoolga Whale Trail, and
- s22 - out of scope

These commitments will be delivered by the Department of Infrastructure, Regional Development and Cities through the Community Development Grants Programme (CDG).

The Australian Government is committed to supporting local communities to prosper and grow. Local infrastructure projects are critical if we want to boost economic growth and improve local amenities and facilities.

A Departmental Officer will contact you shortly to discuss the next steps. This includes undertaking any final due diligence and preparing a Deed of Agreement. Whilst this letter confirms the commitment to your projects, funding of \$1.1 million and \$205,000 respectively, is contingent upon the provision of sufficient information to the Department to allow a value with public money assessment and the execution of a Deed of Agreement.

I recommend you do not enter into financial commitments or begin work on the project until such time a Deed of Agreement has been signed with the Australian Government. Please note that the contents of this letter should be kept confidential until a Deed of Agreement is signed with the Australian Government.

I wish you every success and look forward to seeing the project completed.

Yours sincerely

Michael McCormack

MS19-002233



Australian Government

**Department of Infrastructure, Transport,
Cities and Regional Development**

To: The Hon Michael McCormack MP (for decision)

cc: Mr Simon Atkinson, Secretary

cc: Mr Alex Foulds, Acting Deputy Secretary

cc: Ms Donna Wieland, Acting Executive Director

**COMMUNITY DEVELOPMENT GRANTS – WOOLGOOLGA WHALE TRAIL,
WOOLGOOLGA, NSW (2019 GOVERNMENT COMMITMENT)**

Action required by: 24 January 2020

Reason: Routine

Recommendations:

1. That, for the purposes of section 71 of the *Public Governance, Performance and Accountability Act 2013* (PGPA Act), you **agree** with the Department of Infrastructure, Transport, Cities and Regional Development's assessment at **Attachment A** that expenditure of relevant money as a grant for funding of up to \$1,100,000 (GST exclusive) from the Community Development Grants Programme to the Coffs Harbour City Council for the Woolgoolga Whale Trail project would be a proper use of relevant money.

Agreed / Not Agreed

2. That you **approve** the expenditure of relevant money as a grant for funding of up to \$1,100,000 (GST exclusive) from the Community Development Grants Programme to the Coffs Harbour City Council for the Woolgoolga Whale Trail project, subject to the Department imposing the risk treatments identified at **Attachment A** and any conditions requested by you in writing.

Approved / Not Approved

3. That you **sign** the attached letters to the grantee and Mr Kevin Hogan MP, Member for Page, advising of your decision at **Attachment B**.

Signed / Not Signed

M. McCormack

14/1/2020

The Hon Michael McCormack MP

Date:

Comments:

Key Points:

Date the project was committed and by whom	The project is consistent with the media release by Mr Kevin Hogan MP, Member for Page, on 17 April 2019, which states Coffs Harbour City Council will receive \$1,100,000 for the Woolgoolga Whale Trail project. Official correspondence on 15 March 2019 from you, to the grantee, Coffs Harbour City Council, confirms the \$1,100,000 commitment towards the Woolgoolga Whale Trail project.
Brief project description	The project will construct a concrete footpath, at least 490 metres in length, between Woolgoolga Beach Reserve and Woolgoolga Headland, including lookouts, elevated boardwalks, seating, shade trees and upgraded car parking.
Project timeline	The project is expected to commence in July 2020 and be completed by August 2021.
Value with relevant money?	Yes
s22	
GST	As the grantee is a Local Government Authority, this funding is not subject to GST.

Stakeholder Implications:

Following your approval, the Department will commence negotiation of an Agreement with the Coffs Harbour City Council for the Woolgoolga Whale Trail project.

Name: Andrew Morris
 Position: Acting General Manager
 Branch: Regional Programs
 Division: Regional Development & Local Government
 Ph: 6274 7192
 Mob: s47F

Contact Officer: s47F
 Section: Community Development Grants
 Ph: s47F

Attachments

s22

- B: Letters advising of your decision, and
- C: Public Governance, Performance and Accountability Act 2013, Rules and the Commonwealth Grants Rules and Guidelines, 1 July 2014 requirements.



The Hon Michael McCormack MP

**Deputy Prime Minister
Minister for Infrastructure, Transport and Regional Development
Leader of The Nationals
Federal Member for Riverina**

Ref: MS19-002233

Councillor Denise Knight
Mayor
Coffs Harbour City Council
Locked Bag 155
COFFS HARBOUR NSW 2450

14 JAN 2020

Dear Mayor

I am pleased to advise you that I have approved funding of up to \$1,100,000 (GST exclusive) under the Community Development Grants Programme to the Coffs Harbour City Council for the Woolgoolga Whale Trail project. This approval delivers on a 2019 Australian Government commitment.

I ask that you keep the details of this letter confidential until a Funding Agreement is signed.

Provision of funding is dependent on the preparation and execution by both parties of a Funding Agreement that sets out the terms and conditions under which the funding is provided, and the settling of other details, including confirmation of final costs and designs. You will shortly be contacted by an officer from the Department of Infrastructure, Transport, Cities and Regional Development to discuss the Funding Agreement.

Please be aware you must enter into a Funding Agreement within four weeks of the project being approved otherwise the offer of funding will be reviewed and may be withdrawn. The funding amount is provided on the basis that it does not attract GST as the payment will be made by one government-related entity to another government-related entity. This circumstance is specifically covered by an appropriation under Australian law and falls within the terms of Australian Taxation Office ruling GSTR 2012/2. You may wish to seek guidance from the Australian Taxation Office or your tax adviser on the impact of Community Development Grants funding on your organisation's taxation liabilities.

I have written to Mr Kevin Hogan MP, Member for Page, advising of the approval for the Woolgoolga Whale Trail.

Your Funding Agreement outlines your obligations regarding acknowledgement and publicity for this project. Should you hold an event to celebrate a milestone for your project, please contact the Department via the project officer you normally deal with. I would appreciate it if you could provide three non-parliamentary sitting dates for your event at least eight weeks prior to the earliest date, so I can do my best to make arrangements to attend. If I am unavailable, I will organise a representative to attend on behalf of the Australian Government and my Department will liaise directly with you.

I wish you every success with the Woolgoolga Whale Trail project.

Yours sincerely



Michael McCormack



The Hon Michael McCormack MP

**Deputy Prime Minister
Minister for Infrastructure, Transport and Regional Development
Leader of The Nationals
Federal Member for Riverina**

Ref: MS19-002233

14 JAN 2020

Mr Kevin Hogan MP
Member for Page
63 Molesworth Street
LISMORE NSW 2480

Kevin
Dear Mr Hogan

I am writing to advise that I have approved funding of up to \$1,100,000 (GST exclusive) under the Community Development Grants Programme to the Coffs Harbour City Council for the Woolgoolga Whale Trail project. This funding approval delivers on a 2019 Australian Government commitment in your electorate.

Provision of funding is dependent on the preparation and execution by both parties of an Agreement that sets out the terms and conditions under which the funding is provided, and the settling of other details, including confirmation of final costs, and final designs.

The Community Development Grants Programme is administered by the Department of Infrastructure, Transport, Cities and Regional Development which will contact Coffs Harbour City Council shortly to discuss the details of the Agreement.

You may wish to contact the project grantee directly to let them know their project has been approved ahead of my letter arriving. My office will contact you in the future should media or event opportunities arise for this project.

I enclose details of the project for your information.

Yours sincerely

Michael McCormack

Michael McCormack

Enc

REQUIREMENTS OF THE *PUBLIC GOVERNANCE, PERFORMANCE AND ACCOUNTABILITY ACT 2013*, RULES, AND THE COMMONWEALTH GRANTS RULES AND GUIDELINES 2017.

Any decision by a Minister to approve expenditure of relevant money must be undertaken in a manner that is consistent with the requirements of the *Public Governance, Performance and Accountability Act 2013* (PGPA Act), Rules, and the Commonwealth Grants Rules and Guidelines 2017 (CGRGs).

The PGPA Act, Rules and CGRGs requirements relevant to the approval of funding for this proposed expenditure of relevant money under the Community Development Grants Programme are:

Requirements under the PGPA Act

Section 71(1) – Approval of proposed expenditure by you requires that you must not approve the proposed expenditure of relevant money unless you are satisfied, after making reasonable enquiries that the expenditure would be a “proper” use of relevant money. “Proper” when used in relation to the use or management of public resources means efficient, effective, economical and ethical use.

Section 71 (2a) requires where you agree with the Department’s recommendation to approve or not approve the expenditure of relevant money for this project, that you must record the terms of approval in writing as soon as practicable after giving your approval. This brief and any attachments, including annotations or conditions recorded by you on these documents, satisfies the requirements of Section 71 (2a) of the PGPA Act.

Section 71 (2b) requires that if you approve a proposed expenditure of relevant money, that you must comply with any other requirements prescribed by the Rules in relation to the approval.

Requirements under the CGRGs – Section 4 – Grants specific Processes and Requirements

The CGRGs contain a mandatory requirement that Entity Staff must provide written advice to you, where you exercise the role of an approver. These requirements are outlined under item 4.6 of the CGRGs and include:

- (a) That the proposed expenditure of relevant money for this project is for purposes of a “grant” as described in item 2.3 of the CGRGs;
- (b) That you are advised of any applicable requirements of the PGPA Act and Rules and the CGRGs relating to any ministerial reporting obligations, including the legal authority of the grant;
- (c) Outlining the application and selection process, including the selection criteria, that were used to select potential grants recipients; and
- (d) The merits of the proposed grant or grants relative to the grant guidelines and the key consideration of achieving value with relevant money.

In addition, item 4.11 of the CGRGs provides that where a Minister approves a proposed grant in his/her own electorate, the Minister must write to the Finance Minister advising of the details. For this purpose it is sufficient to provide the Finance Minister with a copy of correspondence to the grantee (except where the Minister has approved a grant which the relevant official has recommended be rejected).

These requirements are addressed under “Key Issues” in the covering brief.

Community Development Grants Programme – Approved Project

Project ID: CDG938

Project Title: Woolgoolga Whale Trail

Project Description: The project will construct a concrete footpath, at least 490 metres in length, between Woolgoolga Beach Reserve and Woolgoolga Headland, including lookouts, elevated boardwalks, seating, shade trees and upgraded car parking.

Grantee/Organisation Name: Coffs Harbour City Council

Grantee/Organisation Type: Local Government Entity

Project Location: Pollack Esplanade, Woolgoolga, NSW 2456

Primary Electorate: Page

Funding Cash Commitment: \$1,100,000 (GST exclusive)

Total Cash Project Value: \$1,100,000 (GST exclusive)

Project Contact:

Name: s47F

Position: Director Sustainable Infrastructure

Phone: s47F

Email:

AGREEMENT DETAILS

These Agreement Details need to be read in conjunction with the Standard Conditions of the Agreement.

Agreement name	Agreement for Woolgoolga Whale Trail project
Department	Commonwealth of Australia represented by the Department of Infrastructure, Transport, Regional Development and Communications ABN 86 267 354 017, 111 Alinga Street, Canberra, Australian Capital Territory (Commonwealth)
Recipient	Coffs Harbour City Council , ABN 79 126 214 487, Corner of Coffs and Castle Street, Coffs Harbour, NSW 2450 (Recipient)
Contact Details	<p>The Commonwealth's details are as follows:</p> <p>Donna Wieland General Manager Regional Programs Branch Department of Infrastructure, Transport, Regional Development and Communications GPO Box 594 CANBERRA ACT 2601 Email: CDG@infrastructure.gov.au</p> <p>The Recipient's details are as follows:</p> <p>s47F</p> <p>General Manager Coffs Harbour City Council Locked Bag 155 Coffs Harbour NSW 2450</p> <p>s47F</p>
Project and Activity (cl 1.2)	<p>The Project to be undertaken by the Recipient is the Woolgoolga Whale Trail project located at Pollack Esplanade, Woolgoolga, NSW 2456. The Project will include the Activity that the Programme will fund.</p> <p>The Activity to be undertaken by the Recipient is the construction of a footpath, at least 490 metres in length, between Woolgoolga Beach Reserve and Woolgoolga Headland, including:</p> <ul style="list-style-type: none"> • at least one mature shade tree; • at least two lookouts; • at least 3.6 metres of seating; • at least 110 metres of elevated boardwalks; • at least 380 metres of concrete footpath; and • at least 633m2 of carpark bitumen resurfacing and kerbing works.
s22	
Other Specific Requirements (cl 1.2)	None Specified
Specified Personnel (cl 1.4)	None Specified

Commonwealth Funding and Payment (cl 2)	The total Commonwealth Funding for the Project is \$1,100,000 excluding GST.														
	Progress Report Number	Milestone(s) / Information covered by the Report	Payment amount (GST Exclusive)												
	1	Evidence acceptable to the Commonwealth that the Recipient has completed the following identified activities: <ul style="list-style-type: none"> confirmation of final costs; and confirmation of final designs. 	Nil												
	2	Evidence acceptable to the Commonwealth that the Recipient has completed the following identified activities: <ul style="list-style-type: none"> 50 per cent of the Project is completed and certified by the Project Manager, Quantity Surveyor, or similar; and an Event Invitation has been submitted to the Department as required at Clause 10. 	\$550,000												
3	Evidence acceptable to the Commonwealth that the following have been achieved: <ul style="list-style-type: none"> confirmation that the Project is completed. 	\$550,000													
Operational Period (cl 25)	The Operational Period commences on the date the Commonwealth accepts the last Report specified, to the Commonwealth's satisfaction. The duration of the Operational Period is dependent on the amount of Funding provided by the Commonwealth under this Agreement. The thresholds are set out in the table below:														
	Amount of Funding	Duration of Operational Period													
	Over \$1,000,000	Five (5) years													
Management of Funding (cl 4)	None Specified														
Budget and Other Contributions (cl 4 and 6)	<table border="1"> <thead> <tr> <th></th> <th>Cost Item</th> <th>Description</th> <th>\$ (GST Exclusive)</th> </tr> </thead> <tbody> <tr> <td>Australian Government</td> <td>Construction</td> <td>Woolgoolga Whale Trail project</td> <td>1,100,000</td> </tr> <tr> <td colspan="3">Total Project Cost</td> <td></td> </tr> </tbody> </table>				Cost Item	Description	\$ (GST Exclusive)	Australian Government	Construction	Woolgoolga Whale Trail project	1,100,000	Total Project Cost			
	Cost Item	Description	\$ (GST Exclusive)												
Australian Government	Construction	Woolgoolga Whale Trail project	1,100,000												
Total Project Cost															
Commonwealth Material and assistance (cl 7)	None Specified														

<p>Acknowledgement and Publicity (cl 10)</p>	<p>The Recipient must agree to acknowledge that the project is supported by funding from the Australian Government under the Community Development Grants Programme.</p> <p>The Recipient must include the Commonwealth logo in all signage, publications and promotional activities related to the Activity. The Recipient must not use the Commonwealth's logo without the Commonwealth's approval. If the Commonwealth provides approval for the Recipient's use of the Commonwealth's logo, the Recipient must use it in accordance with the Commonwealth's branding guidelines (available on the Department of Infrastructure, Transport, Regional Development and Communications website).</p> <p>If the Recipient erects or maintains any signage in relation to the Project, the signage must be approved by the Commonwealth prior to use and contain an acknowledgement of the Funding as required under Clause 10 of this Agreement. Any signage must remain in place during the Operational Period for the Project as specified in Clause 25. Signage for the Activity may be paid from the Budget if approved by Us. Signage for any other part of the Project must be at the Recipient's own cost. If a Federal, State or Local Government election is announced, the Recipient must cover any sign that is displayed within 100 metres of a polling place with an opaque (impenetrable to sight), durable and water repellent material from a period not less than 48 hours before the commencement of polling at that polling place until the polls close.</p> <p>The Recipient must conduct an official opening of the completed Project unless otherwise agreed by the Commonwealth.</p> <p>The recipient must, through the Commonwealth's contact officer:</p> <ul style="list-style-type: none"> • Seek the Commonwealth's agreement for the date of official openings or any other official functions relating to the Project, providing to the Commonwealth with at least three options for dates, at least 56 days prior to the first proposed date, for the official opening or function; • Invite the Commonwealth's representative to officiate at any official opening or other official function relating to the Project; and • Clear all the signage, publications, promotional activities, publicity, announcements and media releases relating to the Project, with at least 14 calendar days' notice, before release.
<p>Reports (cl 15)</p>	<p>The Commonwealth will provide a Progress Report for completion no later than the Milestone Completion Date specified, unless otherwise requested by the Recipient.</p> <p>The Recipient must provide the Commonwealth with the completed Progress Report (including satisfactory evidence) by the Due Date for the Report specified.</p> <p>Throughout the Term of this Agreement, the Commonwealth may require the Recipient to provide ad-hoc reports.</p>
<p>Policies (cl 22.1)</p>	<p>None Specified</p>
<p>Applicable law (cl 23)</p>	<p>The Laws of the Australian Capital Territory apply to this Agreement.</p>

SIGNED for and on behalf of the **COMMONWEALTH OF AUSTRALIA**, as represented by and acting through the **Department of Infrastructure, Transport, Regional Development and Communications: ABN 86 267 354 017**

Executed on behalf of **COFFS HARBOUR CITY COUNCIL**, ABN 79 126 214 487 who by signing warrants they are authorised to bind the **Coffs Harbour City Council**

s47F [Redacted]

General Manager
Regional Programs Branch

s47F [Redacted]

Signed

In the presence of:

s47F [Redacted]

Name
Regional Programs Branch

s47F [Redacted]

Signed

Date:

31 March 2020

s47F [Redacted]

General Manager
Coffs Harbour City Council

s47F [Redacted]

Signed

In the presence of:

s47F [Redacted]

Name of witness

s47F [Redacted]

Signed

Date:

30.03.20

Standard Conditions of the Agreement

1. Term and Conduct of the Project and Activity

- 1.1. This Agreement commences on the Date of this Agreement and continues until the Completion Date, unless terminated earlier.
- 1.2. The Recipient agrees to carry out the Project and Activity diligently, efficiently, effectively and to a high standard, within the Activity Period and to comply with any Other Specific Requirements set out in the Agreement Details or otherwise in this Agreement.
- 1.3. The Recipient agrees to liaise with and provide information to the Commonwealth as reasonably notified by the Commonwealth and comply with all of the Commonwealth's reasonable requests, directions, or monitoring requirements.
- 1.4. The Recipient agrees that the Specified Personnel will perform work in relation to the Activity in accordance with this Agreement.

2. Funding and Payment

- 2.1. The Commonwealth agrees to pay the Funding to the Recipient at the times and in the manner specified in the Agreement Details, provided that sufficient funds are available for the Activity and that the Recipient has fully and properly complied with its obligations under this Agreement.
- 2.2. Without limiting the Commonwealth's rights, the Commonwealth may suspend any payment in whole or in part until the Recipient has performed its obligations under this Agreement.

3. Subcontracting

- 3.1. The Recipient agrees not to subcontract the performance of any obligations under this Agreement without the Commonwealth's prior written approval.
- 3.2. The Recipient acknowledges, and must inform all subcontractors that, the Commonwealth may publicly disclose the names of any subcontractors engaged in the performance of the Activity. The Recipient agrees to make available to the Commonwealth (if requested) details of all subcontractors engaged in the performance of the Activity.
- 3.3. Notwithstanding any subcontracting, the Recipient remains fully responsible for the performance of the Recipient's obligations under this Agreement.

4. Management of Funding

- 4.1. The Recipient agrees to:
 - a. spend the Funding only for the Project and Activity in accordance with this Agreement, including the Budget, if any;
 - b. ensure that the Funding is held in an account in the Recipient's name and which the Recipient solely controls, with an authorised deposit-taking institution authorised under the *Banking Act 1959* (Cth) to carry on banking business in Australia;
 - c. identify the receipt and expenditure of the Funding separately within the Recipient's accounts and records so that at all times the Funding is identifiable; and
 - d. keep financial accounts and records relating to the Activity so as to enable all receipts and payments related to the Activity to be identified and reported in accordance with this Agreement.
- 4.2. If at any time during the term of this Agreement (including on the Completion Date):
 - a. there remains an amount of Funding that has not been spent or legally committed for expenditure in

accordance with the Agreement and the period in which that Funding was expected to be spent or legally committed has passed; or

- b. an amount of Funding has been spent in contravention of the Agreement,

the Commonwealth may (at its discretion and in addition to any other rights it may have) by notice in writing to the Recipient:

- c. require the Recipient to refund this amount to the Commonwealth within 20 Business Days (or other such period specified in the notice); or
- d. reduce any further payments of Funding to the Recipient (if applicable) by an amount up to this amount.

- 4.3. If clause 4.2.a applies, the Commonwealth may by notice in writing require the Recipient to otherwise deal with this amount in accordance with any conditions that the Commonwealth considers appropriate, including conditions relating to the ongoing use and expenditure by the Recipient of that amount for particular goals or objectives associated with the Activity.

- 4.4. The Recipient must immediately notify the Commonwealth in writing if any of the events in clauses 4.2.a or 4.2.b occurs.

- 4.5. The Recipient agrees that any amount owed or payable to the Commonwealth or which the Commonwealth is entitled to recover from the Recipient under this Agreement, is a debt due by the Recipient without further proof of the debt by the Commonwealth being necessary. Such payment is without prejudice to any other rights available to the Commonwealth under the Agreement, under statute, at law or in equity.

5. Taxes and charges

- 5.1. Unless otherwise indicated, the Recipient agrees to pay all taxes, duties and government charges imposed or levied in Australia or overseas in connection with the performance of this Agreement.
- 5.2. Unless otherwise indicated, any consideration for a supply made under this Agreement is exclusive of any GST.
- 5.3. If one party (the supplier) makes a taxable supply to the other party (the recipient) under this Agreement, on receipt of a tax invoice from the supplier, the recipient will pay without setoff an additional amount to the supplier equal to the GST imposed on the supply in question.
- 5.4. No party may claim or retain from the other party any amount in relation to a supply made under this Agreement for which the first party can obtain an input tax credit or decreasing adjustment.

6. Other Contributions

- 6.1. The Recipient must before the first payment for the Project provide to the Commonwealth satisfactory written evidence that confirms the Other Contributions identified the Agreement Details, including the amounts to be provided, the due dates for each of these amounts and the terms and conditions of the provision of the Other Contributions.
- 6.2. Reserved.
- 6.3. If the Recipient does not provide the Recipient Contributions or obtain the Other Contributions (if any) as required in the Agreement Details, in time to enable completion of the Activity, then the Commonwealth may:
 - a. suspend payment of the Funding or an instalment of the Funding (as the case may be) until the Recipient Contributions are provided and/or the Other Contributions are obtained; or

- b. terminate this Agreement in accordance with clause 13.

7. Commonwealth Material

- 7.1. The Commonwealth agrees to provide Commonwealth Material and assistance to the Recipient as specified in the Agreement Details.
- 7.2. Nothing in this Agreement affects the ownership of Commonwealth Material.
- 7.3. The Commonwealth grants the Recipient a licence to use the Intellectual Property in the Commonwealth Material for the sole purpose of performing the Activity in accordance with this Agreement.

8. Intellectual Property

- 8.1. Subject to this clause 8, Intellectual Property in all Activity Material vests or will vest in the Recipient.
- 8.2. Clause 8.1 does not affect:
- the position between the Recipient and a third party; or
 - the ownership of Intellectual Property in any material in existence on the date this Agreement is made.
- 8.3. The Recipient grants to (or will procure for) the Commonwealth a perpetual, irrevocable, royalty-free, world-wide, non-exclusive licence (including a right of sub-licence) to use, reproduce, adapt, modify, perform, distribute, communicate and exploit Intellectual Property Rights in the Activity Material for any purpose and a right to licence any Intellectual Property to the public under an open access licence (including a Creative Commons Attribution licence).

9. Privacy

- 9.1. The Recipient agrees to comply and ensure that its officers, employees, agents and subcontractors comply with the *Privacy Act 1988* (Cth) and do (or refrain from doing) anything required to ensure that the Commonwealth is able to comply with its obligations under that Act. The Recipient will immediately notify the Commonwealth if the Recipient becomes aware of a breach or possible breach of any of its obligations under this clause 9.1
- 9.2. The provisions of this clause 9 survive termination or expiration of this Agreement.

10. Acknowledgement and publicity

- 10.1. The Recipient agrees, in any publicity in relation to the Funding, to acknowledge the financial or other support the Recipient has received from the Australian Government, in the manner approved by the Commonwealth.

11. Indemnity

- 11.1. The Recipient indemnifies (and agrees to keep indemnified) the Commonwealth against any:
- cost or liability incurred by the Commonwealth or the Commonwealth's Personnel;
 - loss of or damage to property of the Commonwealth; or
 - loss or expense incurred by the Commonwealth in dealing with any claim against it, including legal costs and expenses on a solicitor/own client basis and the cost of time spent, resources used, or disbursements paid by the Commonwealth,
- arising from:
- a breach by the Recipient of the Agreement; and
 - an act or omission by the Recipient or the Recipient's Personnel, in connection with this Agreement, where there was fault on the part of the person whose conduct gave rise to that cost, liability, loss, damage, or expense.

- 11.2. The Recipient's liability to indemnify the Commonwealth under this clause 11 will be reduced proportionally to the extent that any act or omission involving fault on the part of the Commonwealth or its Personnel contributed to the relevant cost, liability, loss, damage or expense.

- 11.3. In this clause 11, 'fault' means any negligent or unlawful act or omission or wilful misconduct.

12. Termination for convenience

- 12.1. The Commonwealth may by notice, at any time and in its absolute discretion, terminate this Agreement or reduce the scope of the Agreement immediately.
- 12.2. In the event of termination under clause 12.1, the Commonwealth will be liable only:
- for payments due and owing to the Recipient under the payment provisions of the Agreement as at the date of the notice; and
 - to reimburse any reasonable costs incurred by the Recipient and directly attributable to the termination of the Agreement or reduction in scope of the Agreement,
- but will not be liable to pay amounts under clause 12.2.a and 12.2.b which would, added to any payments already paid to the Recipient under this Agreement, together exceed the Funding set out in the Agreement Details.
- 12.3. In the event of a reduction in the scope of the Agreement under clause 12.1, the Commonwealth's liability to pay any part of the Funding will reduce in accordance with the reduction in the Activity.

13. Termination for fault

- 13.1. If the Recipient fails to fulfil, or is in breach of any of its obligations under this Agreement, the Commonwealth may by notice terminate this Agreement immediately.

14. Records

- 14.1. The Recipient must create and maintain full and accurate accounts and records of the conduct of the Activity.
- 14.2. The Recipient agrees to retain the records and accounts referred to in clause 14.1 and retain them for a period of no less than 7 years after the end of the Activity Period.

15. Reports

- 15.1. The Recipient agrees to provide the Commonwealth with Reports at the times, in the manner and containing the information specified in the Agreement Details.
- 15.2. Throughout the Activity Period, the Commonwealth may require the Recipient to provide ad hoc Reports within the timeframe notified by the Commonwealth.

16. Audit and access

- 16.1. The Recipient agrees to give the Commonwealth, or any persons authorised in writing by the Commonwealth (including the Auditor-General and the Privacy Commissioner), access to premises where the Activity is being performed and to permit those persons to inspect and take copies of any material relevant to the Activity.

17. Insurance

- 17.1. The Recipient will effect and maintain insurance policies of the types and with the amounts of cover that a prudent operator in the Recipient's industry would consider normal and adequate including when carrying out activities of the kind performed by the Recipient pursuant to this Agreement.

18. Conflict of interest

- 18.1. The Recipient warrants that, at the date of entering into this Agreement, no conflict of interest exists or is likely to arise in the performance of the Activity.

- 18.2. If, during the period of the Agreement a conflict arises, or appears likely to arise, the Recipient agrees:
- to notify the Commonwealth; and
 - to take any steps the Commonwealth reasonably requires to resolve or otherwise deal with the conflict.

19. Relationship of parties

- 19.1. The Recipient is not by virtue of this Agreement an officer, employee, partner or agent of the Commonwealth, nor does the Recipient have any power or authority to bind or represent the Commonwealth.
- 19.2. The Recipient agrees:
- not to misrepresent its relationship with the Commonwealth; and
 - not to engage in any misleading or deceptive conduct in relation to the Activity.

20. Variation

- 20.1. A variation of this Agreement is binding only if agreed in writing and signed by the parties.

21. Assignment

- 21.1. The Recipient cannot assign its obligations, and agrees not to assign its rights, under this Agreement without the Commonwealth's prior written approval.

22. Compliance with laws and policies

- 22.1. The Recipient agrees to comply with all provisions of statutes or subordinate legislation of the Commonwealth, or of a State, Territory or local authority applicable to its performance of this Agreement including without limitation all legislation relating to occupational health and safety, industrial relations and security and the Commonwealth's policies as notified, referred or made available by the Commonwealth to the Recipient, including those listed in the Agreement Details.
- 22.2. Without limiting clause 1.3 of this Agreement, the Recipient agrees to, on request, give all reasonable assistance to the Commonwealth, by way of provision of information and documents, to assist the Commonwealth and its officers (as defined in the Work Health and Safety Act 2011 (Cth) (WHS Act)) to comply with the duties imposed on them under the WHS Act.
- 22.3. The Recipient acknowledges that the Commonwealth may direct the Recipient to take specified measures in connection with the Recipient's work under this Agreement or otherwise in connection with the Activity that the Commonwealth considers reasonably necessary to deal with an event or circumstance that has, or is likely to have, an adverse effect on the health or safety of persons. The Recipient must comply with the direction. The Recipient agrees that it is not entitled to an adjustment to the Funding merely because of compliance with the direction.
- 22.4. The Recipient must not enter into any subcontract for the purpose of directly or indirectly fulfilling its obligations under this Agreement unless such a subcontract obliges the subcontractor to comply with equivalent provisions to those contained in this clause 22.

23. Applicable law

- 23.1. This Agreement is to be construed in accordance with, and any matter relating to it is to be governed by, the law of the State or Territory specified in the Agreement Details.
- 23.2. The parties submit to the jurisdiction of the courts of that State or Territory.

24. Definitions and Interpretation

- 24.1. In addition to the terms described in the Agreement Details:

Agreement Details means the relevant document headed 'Agreement Details';

Activity Material means any material:

- created by the Recipient for the purpose of this Agreement;
- provided or required to be provided to the Commonwealth under the Agreement; or
- derived at any time from the material referred to in paragraphs a. or b.;

and includes

- any Reports;

Budget means the budget, if any, specified in the Agreement Details for the expenditure of the Funding;

Business Days means in relation to the doing of any action in a place, any day other than a Saturday, Sunday, or public holiday in that place;

Completion Date means the day after the Recipient has done all that it is required to do under this Agreement to the satisfaction of the Commonwealth;

Date of this Agreement means the date the copy of the letter to which the Agreement Details and the Standard Conditions of the Agreement were attached is signed by the Recipient;

GST has the meaning that it has in the *A New Tax System (Goods and Services Tax) Act 1999* (Cth);

Information Privacy Principle has the meaning that it has in the *Privacy Act 1988* (Cth);

Intellectual Property includes all copyright (including rights in relation to phonograms and broadcasts); all rights in relation to inventions, plant varieties, trademarks (including service marks), designs and circuit layouts; and all other rights resulting from intellectual activity in the industrial, scientific, literary or artistic fields, but does not include: moral rights; the non-proprietary rights of performers; or rights in relation to confidential information;

Other Contributions means financial or in-kind resources (with in-kind resources valued at cost other than the Funding, which are specified in the Agreement Details and are to be used by the Recipient to perform the Project;

Personnel means a party's officers, employees, agents, contractor staff or professional advisers engaged in, or in relation to, the performance of the Activity or the management of this Agreement;

- 24.2. This Agreement comprises:

- these Standard Conditions of the Agreement;
- the Agreement Details;
- any attachments to these Standard Conditions of the Agreement; and
- any other document incorporated by reference.

- 24.3. If any conflict arises between the terms and conditions contained in this Agreement, the order of priority will be as set out in clause 24.2.

- 24.4. Clauses 4, 7, 8, 9, 11, 14, 16 and 17 survive the termination or expiry of this Agreement, as well as any other provision which expressly or by implication from its nature is intended to continue.

25. Operational Period

- 25.1. The Recipient must use the Assets created, acquired, or upgraded under this Agreement for the Purpose set out in Agreement Details for the duration of the Operational Period.

Coffs Harbour City

Economic impact model

Economic impact modelling enables Coffs Harbour City to explore how change in employment or output(sales) in one sector of the local economy will impact on all other sectors of the economy, by modelling the flow-on effects across different industries.

This provides Coffs Harbour City with powerful evidence to advocate against industrial closures or strategically target new industry sectors which are likely to have the greatest positive economic impact.

Different industries will have different flow on effects. Adding jobs in a particular sector will not only add to the value of that sector, but also to other industries related to the supply chain (eg. suppliers, wholesalers) and service industries (retail, food services, administration) which will expand to service the additional workforce. Jobs in associated industries may be added in the local area or outside it, based on journey to work information.

The economic impacts are calculated using an input-output model which is derived from the local economy microsimulation model by National Economics (NIEIR).

To use the model, simply input the number of jobs (per year) to be added (+) or removed (-) from the economy in a particular industry sector. The results show the theoretical addition (or loss) to the local economy of jobs and value added by industry sector. It also shows the proportion of the new employment that would occur inside and outside Coffs Harbour City.

To model construction impacts related to a project, input the total cost of construction or direct jobs created. The results shown will represent total direct and indirect impacts over the life of the construction period. To estimate annual impacts, simply divide the total impacts by the estimated life of the project in years (e.g. divide results by 3 if the project will take 3 years to build, or 1.5 for 18 months).

Industry: Building Construction
Impact modeled: ADDITION of \$1.1 million sales
Company name: Whale Trail 2

Impact Summary

Coffs Harbour City - Modelling the effect of adding \$1.1m sales in Building Construction - Inflation adjusted

Summary	Output (\$m)	Value-added (\$m)	Local jobs	Residents jobs
Starting position Coffs Harbour City (year ended June 2018)	--	--	--	--
Building Construction	156.03	38.74	724	659
All industries	6,325.43	2,785.43	34,858	33,166
Impacts on Coffs Harbour City economy	--	--	--	--
Direct impact on Building Construction sector	1.10	0.27	5	--
Industrial impact	0.59	0.22	2	--
Consumption impact	0.11	0.04	0	--
Total impact on Coffs Harbour City economy	1.79	0.53	8	9
▪ Type 1 multiplier (direct & industrial)	1.53	1.79	1.47	--
▪ Type 2 multiplier (direct, industrial & consumption)	1.63	1.94	1.56	--
Impact on New South Wales economy	--	--	--	--
Total impact - New South Wales outside Coffs Harbour City	0.59	0.27	2	3
Total impact New South Wales economy	2.38	0.80	10	12
Impact on Australian economy	--	--	--	--
Total impact outside New South Wales economy	0.65	0.30	3	3
Total impact on Australian economy	3.03	1.10	13	15

Impact on Output

The direct addition of \$1.1 million annual output in the Building Construction sector of Coffs Harbour City economy would lead to an increase in indirect demand for intermediate goods and services across related industry sectors. These indirect industrial impacts (Type 1) are estimated to be an additional \$0.59m in Output, representing a Type 1 Output multiplier of 1.53.

There would be an additional contribution to Coffs Harbour City economy through consumption effects as correspondingly more wages and salaries are spent in the local economy. It is estimated that this would result in a further increase in Output of \$0.11m .

The combination of all direct, industrial and consumption effects would result in total estimated rise in Output of \$1.79m in Coffs Harbour City economy, representing a Type 2 Output multiplier of 1.63.

These impacts would not be limited to the local economy. Industrial and consumption effects would flow outside the region to the wider Australian economy to the tune of \$1.24m in Output.

The combined effect of economic multipliers in Coffs Harbour City and the wider Australian economy is estimated to be \$3.03m added to Australia's Output.

Impact on Local Employment (jobs)

The direct addition of \$1.1 million annual output in the Building Construction sector of Coffs Harbour City economy is estimated to lead to a corresponding direct addition of 5 jobs in the local Building Construction sector. From this direct expansion in the economy it is anticipated that there would be flow on effects into other related intermediate industries, creating an additional 2 jobs. This represents a Type 1 Employment multiplier of 1.47.

This addition of jobs in the local economy would lead to a corresponding increase in wages and salaries, a proportion of which would be spent on local goods and services, creating a further -- jobs through consumption impacts.

The combination of all direct, industrial and consumption effects would result in a total estimated increase of 8 jobs located in Coffs Harbour City. This represents a Type 2 Employment multiplier of 1.56.

Employment impacts would not be limited to the local economy. Industrial and consumption effects would flow outside the region to the wider Australian economy creating a further 5 jobs.

The combined effect of economic multipliers in Coffs Harbour City and the wider Australian economy is estimated to be an addition of 13 jobs.

Impact on value added

The direct addition of \$1.1 million annual output in the Building Construction sector of Coffs Harbour City economy would lead to a corresponding direct increase in value added of \$0.27m. A further \$0.22m in value added would be generated from related intermediate industries. These indirect industrial impacts represent a Type 1 value added multiplier of 1.79.

There would be an additional contribution to Coffs Harbour City economy through consumption effects as correspondingly more wages and salaries are spent in the local economy. It is estimated that this would result in a further increase in value added of \$0.04m.

The combination of all direct, industrial and consumption effects would result in an estimated addition in value added of \$0.53m in Coffs Harbour City economy, representing a Type 2 value added multiplier of 1.94.

These impacts would not be limited to the local economy. Industrial and consumption effects would flow outside the region to the wider Australian economy to the tune of \$0.57m in value added.

The combined effect of economic multipliers in Coffs Harbour City and the wider Australian economy is estimated to be \$1.10m added to Australia's value added.

Impact on GRP

Value added by industry represents the industry component of Gross Regional Product(GRP). The impact on Coffs Harbour City's GRP as a result of this change to the economy is directly equivalent to the change in value added outlined in the section above.

In summary, GRP in Coffs Harbour City is estimated to increase by \$0.53m.

The effect on the Australian economy (including Coffs Harbour City) is estimated to be a growth in Gross Domestic Product(GDP) of \$1.10m.

Impact on employment by industry sector

This table shows a detailed breakdown of how employment will be affected by the addition of \$1.1 million annual output in the Building Construction sector of Coffs Harbour City economy. This includes both the direct industrial impact (Type 1) and ongoing consumption impact (Type 2).

Employment by industry sector

Coffs Harbour City - Impact of \$1.1 million new sales in 'Building Construction' output (Type 1 & 2 combined impact)

Employment impacts

Industry sectors (1-digit ANSIC)	Existing jobs in Coffs Harbour City*	Jobs created in Coffs Harbour City	Jobs created outside of Coffs Harbour City	Jobs created for Coffs Harbour City residents
Agriculture, Forestry and Fishing	1,732	0	0	0
Mining	153	0	0	2
Manufacturing	1,545	1	0	1
Electricity, Gas, Water and Waste Services	360	0	0	0
Construction	3,284	6	0	6
Wholesale Trade	1,011	0	0	0
Retail Trade	4,108	0	1	0
Accommodation and Food Services	3,231	0	0	0
Transport, Postal and Warehousing	1,292	0	0	0
Information Media and Telecommunications	357	0	0	0
Financial and Insurance Services	525	0	0	0
Rental, Hiring and Real Estate Services	526	0	0	0
Professional, Scientific and Technical Services	1,539	0	1	0
Administrative and Support Services	993	0	0	0
Public Administration and Safety	2,136	0	0	0
Education and Training	3,299	0	0	0
Health Care and Social Assistance	6,681	0	0	0
Arts and Recreation Services	549	0	0	0
Other Services	1,534	0	0	0
Total Industries	34,858	8	5	9

Source: [National Institute of Economic and Industry Research \(NIEIR\)](#) ©2019. Compiled and presented in economy.id by [.id](#) The population experts

Employment by industry sector

Impact of \$1.1 million new sales in Building Construction sector

■ Jobs created in Coffs Harbour City ■ Jobs created outside Coffs Harbour City

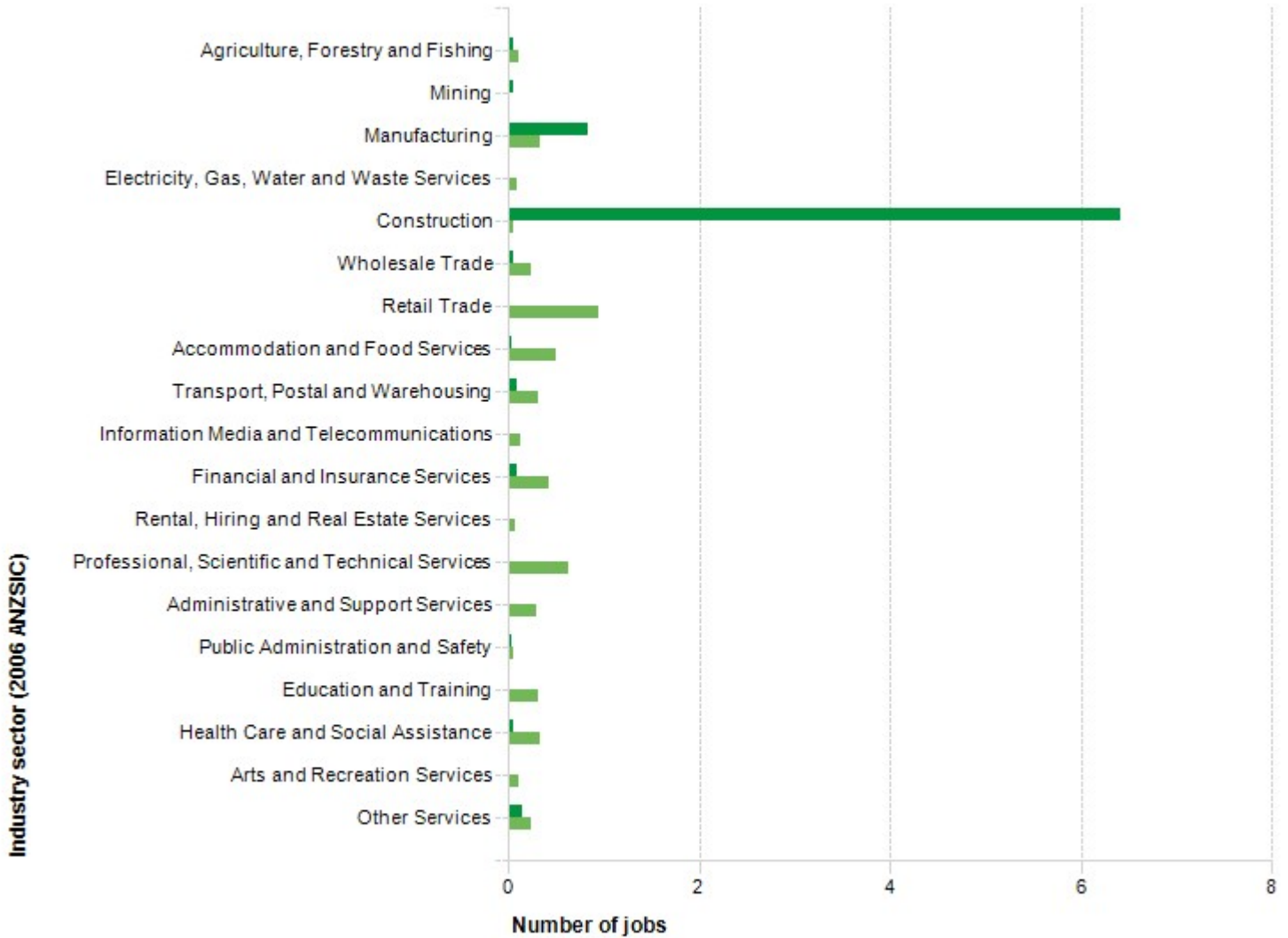

Source: National Institute of Economic and Industry Research (NIEIR) ©2019
 Compiled and presented in economy.id by .id the population experts



Resident employment impacts

The combination of all direct, industrial and consumption effects of adding \$1.1 million annual output to the Building Construction sector of Coffs Harbour City economy would be an estimated increase of 9 jobs located in Coffs Harbour City and 6 jobs located outside Coffs Harbour City – a total of 15 jobs.

As some of Coffs Harbour City’s residents leave the area to work and residents of other areas enter Coffs Harbour City to work, not all of these jobs will be filled by Coffs Harbour City residents. It is estimated that of the 15 jobs created, 9 or 60.2% would be expected to be filled by Coffs Harbour City residents.

Industry employment impacts

The combination of all direct, industrial and consumption effects of adding \$1.1 million annual output to the Building Construction sector of Coffs Harbour City economy would result in an estimated increase of 8 jobs located in Coffs Harbour City.

Of the 8 jobs created within Coffs Harbour City, 6, or 80.8% would be added within Construction the sector. This includes the direct jobs created in the sector, and the effect of flow-on jobs within the same sector.

The largest increase in jobs outside Construction would be in Manufacturing (1), Other Services (0) and Transport, Postal and Warehousing (0).

A total of 5 jobs are estimated to be created outside Coffs Harbour City, with the largest number being in Retail Trade (1) Professional, Scientific and Technical Services (1) and Accommodation and Food Services (0).

Impact on value added by industry sector

This table shows a detailed breakdown of how adding \$1.1 million annual output in the Building Construction sector of Coffs Harbour City economy will impact on the value added of each industry sector. This highlights the relationships between industry. This includes both the direct industrial impact (Type 1) and ongoing consumption impact (Type 2).

Value-added by industry

Coffs Harbour City - Impact of \$1.1 million new sales in 'Building Construction' output (Type 1 & 2 combined impact) **Value added 2017-18 (\$m constant prices)**

Industry sectors (1-digit ANSIC)	Value-added to Coffs Harbour City	Percentage change	Value-added to Australian economy
Agriculture, Forestry and Fishing	\$0.01	0.0%	\$0.02
Mining	\$0.01	0.0%	\$0.02
Manufacturing	\$0.07	0.1%	\$0.12
Electricity, Gas, Water and Waste Services	\$0.00	0.0%	\$0.03
Construction	\$0.38	0.1%	\$0.38
Wholesale Trade	\$0.01	0.0%	\$0.05
Retail Trade	\$0.00	0.0%	\$0.06
Accommodation and Food Services	\$0.00	0.0%	\$0.02
Transport, Postal and Warehousing	\$0.01	0.0%	\$0.05
Information Media and Telecommunications	\$0.00	0.0%	\$0.03
Financial and Insurance Services	\$0.02	0.0%	\$0.10
Rental, Hiring and Real Estate Services	\$0.00	0.0%	\$0.02
Professional, Scientific and Technical Services	\$0.00	0.0%	\$0.08
Administrative and Support Services	\$0.00	0.0%	\$0.04
Public Administration and Safety	\$0.00	0.0%	\$0.01
Education and Training	\$0.00	0.0%	\$0.02
Health Care and Social Assistance	\$0.00	0.0%	\$0.03
Arts and Recreation Services	\$0.00	0.0%	\$0.01
Other Services	\$0.01	0.0%	\$0.02
Total Industries	\$0.53	0.0%	\$1.10

Source: [National Institute of Economic and Industry Research \(NIEIR\)](#) ©2019. Compiled and presented in economy.id by [.id](#) The population experts

Value-added by industry

Impact of \$1.1 million new sales in Building Construction sector

■ Value-added to Local GRP (industry)
 ■ Value-added to total Australian economy

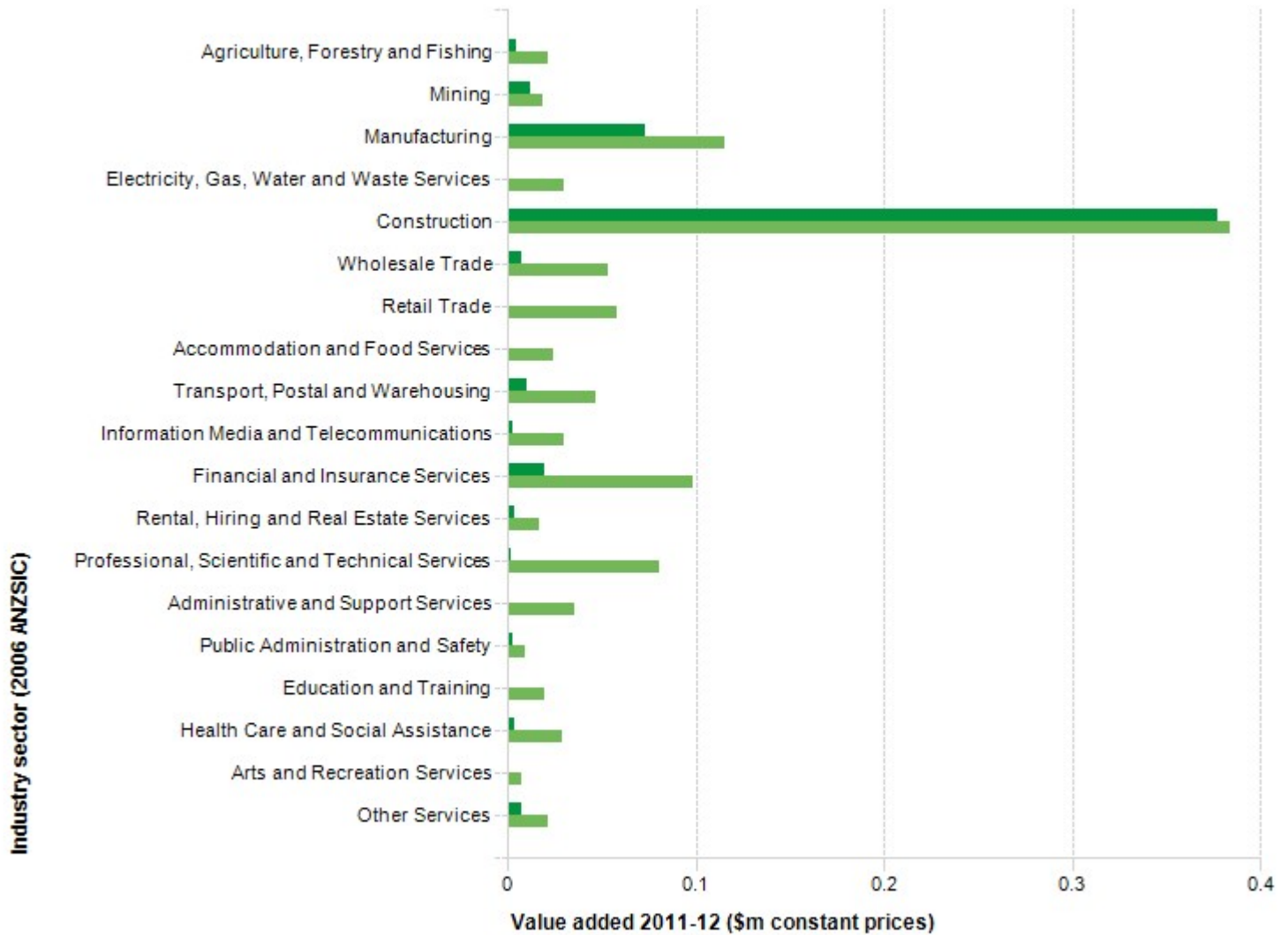

Source: National Institute of Economic and Industry Research (NIEIR) ©2019
 Compiled and presented in economy.id by .id the population experts



The combination of all direct, industrial and consumption effects of adding \$1.1 million annual output to the Building Construction sector of Coffs Harbour City economy would result in an estimated increase in value added of \$0.53m in Coffs Harbour City economy.

The Construction sector of the economy is estimated to increase in value added by 0.1%, with the total Coffs Harbour City economy estimated to grow by 0%.

The main impacts in value added within Coffs Harbour City, outside of Construction, are in Manufacturing (0.07m), Financial and Insurance Services (0.02m) and Mining (0.01m).

copyright © 2019 .id Consulting Pty Ltd ACN 084 054 473. All rights reserved.
 Please read our [Report Disclaimer](#) and [Copyright Notice](#) which governs your use of this report.



WOOLGOOLGA WHALE TRAIL

ORDER OF COST ESTIMATE 18.9.2019



Stage 1 - Ramps to Carrington and Pollack

Redundant Objects	Qty	Rate to remove	Cost
Table / Chairs and conc slab	2	\$ 2,000.00	\$ 4,000.00
Minor Trees	3	\$ 500.00	\$ 1,500.00
Driveway	1	\$ 2,000.00	\$ 2,000.00
Pipe and headwalls	10	\$ 50.00	\$ 500.00
Topsoil from carpark (m3)	145.5	\$ 17.93	\$ 2,608.70
Subtotal - Redundant Objects 1			\$ 10,608.70

New construction	Length	Width	Area	Rate	Cost
Stairs from viewing platform	51.5	2	103	\$ 746.93	\$ 76,933.64
Ramp from viewing platform	17.5	2	35	\$ 654.57	\$ 22,910.11
Viewing platform	8.5	5.5	46.75	\$ 654.57	\$ 30,601.36
Platform erosion protection	12.5	2.5	31.25	\$ 100.00	\$ 3,125.00
Concrete footpath adjacent roadway	50	1.8	90	\$ 139.05	\$ 12,514.50
Footpath Earthworks (minor)	50	2.5	125	\$ 19.67	\$ 2,458.64
Concrete footpath adjacent carpark	98.5	1.8	177.3	\$ 139.05	\$ 24,653.57
Subtotal - New construction 1					\$ 173,196.81

Roadworks	Length	Width	Area	Rate	Cost
Widening works	25	5.7	213.75	\$ 85.00	\$ 18,168.75
Crossfall Improvement works	25	2.3	86.25	\$ 54.46	\$ 4,697.57
Subsoils under kerb	25			\$ 98.48	\$ 2,461.89
Pavement Surfacing	25	7	175	\$ 7.10	\$ 1,242.98
New kerbing (roll kerb)	25			\$ 251.33	\$ 6,283.18
Driveway rebuild (small)					\$ -
Driveway rebuild (large)	1			\$ 6,180.00	\$ 6,180.00
450mm drainage (as per strategy)	15			\$ 426.16	\$ 6,392.45
Small drainage pit (KIP)	1			\$ 3,496.73	\$ 3,496.73
Subtotal - Roadworks 1					\$ 48,923.54

New Carpark	Length	Width	Area	Rate	Cost
Carpark Pavement			485	\$ 85.00	\$ 41,225.00
Carpark Surface			485	\$ 7.10	\$ 3,444.82
Subsoils	97.5			\$ 98.48	\$ 9,601.36
Carpark Edging (barrier Kerb)	77			\$ 251.33	\$ 19,352.20
Subtotal - Carpark 1					\$ 126,043.64

Stage 2 - Park from Carpark north

Redundant Objects	Qty	Rate to remove	Cost
Bollard Fence	90.5	\$ 10.00	\$ 905.00
Bin	1	\$ 150.00	\$ 150.00
Subtotal - Redundant Objects 2			\$ 1,055.00

New construction	Length	Width	Area	Rate	Cost
Concrete footpath through park	98	2	196	\$ 139.05	\$ 27,253.80
Bollard fence adjacent carpark	90.5			\$ 40.41	\$ 3,656.76
Viewing platform	1.5	2	3	746.93	\$ 2,240.79
Stairs to waterfront access	18	1.5	27	746.93	\$ 20,167.07
Path earthworks	110	4	440	\$ 19.67	\$ 8,654.40
Subtotal - New construction 2					\$ 61,972.81

Stage 3 - Footpath / Footbridge to Arthur St

Redundant Objects	Qty	Rate to remove	Cost
Small scale vegetation only (m2)	163.8	\$ 5.00	\$ 819.00
Remove timber bollards	147	\$ 10.00	\$ 1,470.00
Subtotal - Redundant Objects 3			\$ 2,289.00

New construction	Length	Width	Area	Rate	Cost
Footpath to Raised walk 1	36.7	2	73.4	\$ 139.05	\$ 10,206.27
Raised walk 1	42	1.8	75.6	926.59	\$ 70,050.11
Boardwalk 1	24	1.8	43.2	926.59	\$ 40,028.64
Raised walk 2	25	1.8	45	926.59	\$ 41,696.50
Earthworks for footpath	36.7	4	146.8	\$ 19.67	\$ 2,887.42
New plastic bollards	147			\$ 40.41	\$ 5,939.70
Subtotal - New construction 3					\$ 170,808.64

Stage 4 - Footpath Arthur St to Pollack

Redundant Objects	Qty	Rate to remove	Cost
Bollards (timber)	158	\$ 10.00	\$ 1,580.00
Subtotal - Redundant Objects 4			\$ 1,580.00

New construction	Length	Width	Area	Rate	Cost
Footpath to drain crossing	53.5	2	107	\$ 139.05	\$ 14,878.35
Raised walk 3 (drain crossing)	6	1.8	10.8	926.59	\$ 10,007.16
Footpath to nature walk	102.9	2	205.8	\$ 139.05	\$ 28,616.49
New bollards	158			\$ 40.41	\$ 6,384.17
Footpath to viewing platform	30	2	60	\$ 139.05	\$ 8,343.00
Earthworks for footpath	186.4	4	745.6	\$ 19.67	\$ 14,665.27
Retaining wall for carpark perimeter	48			\$ 664.12	\$ 31,877.92
Viewing platform	4	2	8	746.93	\$ 2,987.71
Subtotal - New construction 4					\$ 117,760.08

New Carpark	Length	Width	Area	Rate	Cost
Kerb and Gutter	55			\$ 251.33	\$ 13,823.00
Subsoils	55			\$ 98.48	\$ 5,416.15
Carpark pavement	45	5.8	261	\$ 85.00	\$ 22,185.00
Carpark surface	45	5.8	261	\$ 7.10	\$ 1,853.81
Subtotal - Carpark 2					\$ 43,277.96

Stage 1 Subtotal					\$ 358,772.69
Stage 2 Subtotal					\$ 63,027.81
Stage 3 Subtotal					\$ 173,097.64
Stage 4 Subtotal					\$ 162,618.04
Establishment					\$ 40,000.00
Project Management					\$ 75,751.62
Contingency					\$ 227,254.85
TOTAL					\$ 1,100,522.65