



**COMMONWEALTH OF AUSTRALIA**

AUSTRALIAN DESIGN RULE 34A  
FOR  
CHILD RESTRAINT ANCHORAGES

As Endorsed by the  
Australian Transport Advisory Council

The intention of this Australian Design Rule is to specify requirements for child restraint upper anchorages for children up to 6 years of age and mass not exceeding 21.4 kg in rear seats of passenger cars. This will facilitate satisfactory installation of child restraints and transfer of restraints between vehicles. It is intended that, except for some bassinets, the lower part of the child restraint shall be secured by the adult seat belt.

The Australian Transport Advisory Council has recommended to Commonwealth, State and Territory Governments that all motor vehicles specified below shall comply with Australian Design Rule 34A - Child Restraint Anchorages.

VEHICLE CATEGORY	RULE		AMENDMENT
	MANUFACTURED ON OR AFTER		
	34A	34A.2.5 +	
Passenger Cars			
Forward Control Passenger Vehicles up to 8 seats	1 Jan 1986#	1 Jan 1987#	
9 seats	1 Jan 1986#	1 Jan 1987#	
Other Passenger Cars	1 Jan 1985	1 Jan 1987	
Passenger Car Derivatives	N/A		
Multi-Purpose Passenger Cars	N/A		
Omnibuses up to 3.5 tonnes GVM			
up to 12 seats	1 Jan 1987#	1 Jan 1987#	
over 12 seats	N/A		
up to 4.5 tonnes GVM	N/A		
over 4.5 tonnes GVM	N/A		
Motorcycles	N/A		
Mopeds	N/A		
Specially Constructed Vehicles	N/A		
Other Vehicles not listed above			
up to 4.5 tonnes GVM	N/A		
over 4.5 tonnes GVM	N/A		

# Applicable to three rear seating positions only.

N/A - Not Applicable

GROSS VEHICLE MASS - Abbreviated to 'GVM'

+ After date shown, the requirements of Clause 34A.2.5 shall supersede the requirements of Clause 34A.2.4

Issued By: Department of Transport  
PO Box 594  
CIVIC SQUARE ACT 2608  
AUSTRALIA

Issued: July 1985

34A.1 Definitions

34A.1.1 Child Restraint Attaching Clip - means the device shown in Fig 1 and designed to be attached to the upper anchor fitting.

Note: Fitting shown in Figs 1 and 2 or their equivalent, together with the corresponding hardware are supplied by the child restraint manufacturer together with details and instructions for their correct installation.

34A.1.2 Design Line of Action - means the centreline of the child restraint attachment, in side elevation and with the seat installed, from the shoulder point to the upper anchor fitting.

34A.1.3 Rear Seat - for the purpose of this Design Rule:

- (a) for Forward Control Passenger Vehicles (FCPVs) - a rear seat is any forward facing seat which lies to the rear of the driver's or the front passenger(s) seating positions.
- (b) for passenger cars (other than FCPVs) - a rear seat is any forward facing seat which lies immediately to the rear of the driver's or the front passenger(s) seating position.

34A.1.4 Seating Reference Plane - for the purpose of this Design Rule is the longitudinal plane as established by either of the conditions set out below:

- (a) Seats designed for one seating position only - the vertical plane through the geometric centre of the seat,
- (b) Seats designed for two or more seating positions - the plane nominated by the manufacturer provided that in the case of an outboard position on a seat which is designed for two occupants only, the seating reference plane shall be at least 200mm from the vertical longitudinal plane through the centre of the vehicle and at least 200mm from the inner panel (or the line of the inner panel) when measured horizontally on a transverse line through the seating reference point.

34A.1.5 Seating Reference Point - for the purpose of this Design Rule means the manufacturer's design reference point which:

- (a) Establishes the rearmost normal design driving or riding position for each designated seating position in a vehicle;
- (b) Has co-ordinates established relative to the designed vehicle structure;
- (c) Simulates the position of the pivot centre of human torso and thigh; and

\* Amended February 1984

(d) Is the reference point employed to position the two dimensional templates described in Society of Automotive Engineers Standard J826b - 'Devices for Use in Defining and Measuring Vehicle Seating Accommodation', September 1974.

34A.1.6 Shoulder Point - for the purpose of this Design Rule means a point 300mm above the seating reference point, measured along the torso reference line and representing the shoulder point of a 50th percentile six years old child.

34A.1.7 Spacer - Annular block used to raise the position of the upper anchor fitting(s) shown in Fig 3.

34A.1.8 Torso Reference Line - a line parallel to the small of the two dimensional template's back and extending through the seating reference point when the seat back is adjusted to a required seat back angle. The two dimensional template is as specified in SAE J826b - 'Devices for Use in Defining and Measuring Vehicle Seating Accommodation', September 1974.

34A.1.9 Upper Anchor Fitting - means the fitting shown in Fig 2 which is attached to the upper anchorage.

34A.1.10 Upper Anchorage - the part of the vehicle designed to transfer loads from the upper part of the child restraint to the vehicle structure. Also designated as the 'Child Restraint Anchorage'.

34A.2 General Requirements

34A.2.1 Anchorage

34A.2.1.1 Passenger Cars Other than FCPVs

For each rear seating position equipped with an adult seat belt assembly, one upper anchorage shall be provided, except that in the case where the seat back is divided into two or more sections which may be folded independently of each other, and the division between two sections lies substantially along the seating reference plane of the middle seating position, an upper anchorage need not be provided for that seating position.

34A.2.1.2 Forward Control Passenger Vehicles

34A.2.1.2.1 For vehicles with less than three rear seating positions an upper anchorage shall be provided for each rear seating position equipped with an adult seat belt assembly.

34A.2.1.2.2 For vehicles with three or more rear seating positions an upper anchorage shall be provided for at least any three rear seating positions equipped with an adult seat belt assembly.

34A.2.2 Each upper anchorage shall incorporate an internal thread of 5/16 - 18 UNC - 2B.

\* Amended February 1984

## AUSTRALIAN DESIGN RULE NO. 34A - CHILD RESTRAINT ANCHORAGES

- 34A.2.2 Each upper anchorage shall incorporate an internal thread of 5/16 - 18 UNC - 2B.
- 34A.2.3 Each upper anchorage shall be so designed and located that:
- (a) It meets the requirements of Clause 34A.3, 34A.4 and 34A.5 when the anchor fitting(s) are installed as recommended by the vehicle manufacturer,
  - (b) No items need to be removed to gain access to the upper anchorage(s), other than closure plugs and items movable without the use of tools.
- 34A.2.4 Information regarding the location of each upper anchorage shall be specified in the vehicle handbook or otherwise supplied with the vehicle. The information shall include:
- (a) 'WARNING: Child restraint anchorages are designed to withstand only those loads imposed by correctly fitted child restraints. Under no circumstances are they to be used for adult seat belts or harnesses.'
  - (b) Details on the thickness of spacers required at each anchorage location and the correct method of installation of upper anchor fitting(s).
  - (c) The length of bolt required to satisfy 34A.5 and achieving a minimum of 5 full threads of engagement when used to install the upper anchorage fitting in accordance with 34A.2.4(b).
- 34A.2.5 Information including either a photograph or a diagram regarding the location of each upper anchorage shall be specified in the vehicle handbook or otherwise supplied with the vehicle. The information shall include:
- (a) 'WARNING: Child restraint anchorages are designed to withstand only those loads imposed by correctly fitted child restraints. Under no circumstances are they to be used for adult seat belts or harnesses.'
  - (b) Details on the thickness of spacers required at each upper anchorage location and the correct method of installation of upper anchor fitting(s).
  - (c) The length of bolt required to satisfy 34A.5 and achieving a minimum of 5 full threads of engagement when used to install the upper anchor fitting in accordance with 34A.2.5(b).

\* Amended March 1985

34A.3 Location Requirements

34A.3.1 The upper anchorage associated with a particular seat belt assembly shall lie within 40mm of the seating reference plane of the seating position for which the seat belt assembly is provided.

34A.3.2 Upper anchorages shall be located within the vehicle.

34A.3.3 Each upper anchorage shall be located rearward of a transverse plane parallel to and 140mm rearward of the torso reference line as shown in Fig. 4.

34A.4 Accessibility

34A.4.1 Clearance shall be provided so that the upper anchor fitting can be installed with a 5/16 - 18 UNC hexagon headed bolt using hand tools. The bolt shall be capable of being engaged for a depth of 5 full threads into the anchorage.

34A.4.2 Clearance shall be provided around each child restraint upper anchorage to allow:

(a) installation of the upper anchorage fitting, spacer or spacers (if specified as in Clause 34A.2.4(b)) and attaching bolt (as specified in Clause 34A.2.4(c)).

(b) latching and unlatching, without the use of tools, of the child restraint attaching clip to the upper anchor fitting when it is installed to the upper anchorage.

34A.4.3 It is permissible to install suitable spacers, to the required height, at the mounting points.

34A.4.3.1 Spacers, if used, will be to the dimensions shown in Fig 3.

34A.5.1 Strength of Anchorage(s)

34A.5.1 Static or dynamic testing shall be conducted at the vehicle manufacturer's choice either to Clause 34A.5.2 or Clause 34A.5.3 as applicable using the anchor fitting and designated spacers at the upper anchorage(s) located and referred to in Clause 34A.2.4.

34A.5.2 Static Testing - all upper anchorages shall be tested simultaneously when installed in the vehicle, and with the seat or seat back installed, by application of a test load of not less than 3.4 kN to each upper anchorage.

The direction of the test load shall be within 20° of the design line of action of the child restraint attachment, and not more than 5° to the left or right of the longitudinal axis of the vehicle.

AUSTRALIAN DESIGN RULE NO. 34A - CHILD RESTRAINT ANCHORAGES

---

Where the design line of action is determined by the seat or seat back, and the upper anchorage is located more than 100 mm below a horizontal plane tangential to the point on the top of the seat back longitudinally forward of the upper anchorage then, with the seat or seat back installed, the load shall be applied forward of the seat back and not more than 5° above or below the horizontal and not more than 5° to the left or right of the longitudinal axis of the vehicle.

Each anchorage shall be capable of supporting the test load for a period of not less than one second.

34A.5.3 Dynamic Test - all anchorages shall be tested simultaneously when installed in the test vehicle body, including the complete rear seat assembly and with test dummies restrained in each rear seating position.

34A.5.3.1 The test dummies shall each have a mass of not less than 21.4 kg or shall comply with the requirements described in technical drawings produced by the TNO (Research Institute for Road Vehicles) - Netherlands for a 50th percentile 6 years old child.

34A.5.3.2 The test dummies shall be restrained in the rear seating positions using suitable child restraints comprising of load bearing material having an elongation of not more than 25% when subjected to a load of 11 kN, and providing for pelvic and upper torso restraint. Each pelvic restraint portion shall be attached to the corresponding seat belt lap anchorages. The upper torso restraint portion shall be attached to the upper anchorage.

34A.5.3.3 The pelvic and upper torso portions of the child restraints shall be adjusted to eliminate slack.

34A.5.3.4 The test rig shall have a mass of not less than 380 kg and shall meet the requirements of Clause 34A.5.3.5 for test rig calibration. It shall comprise of trolley, the test vehicle body or part thereof, and the complete rear seat assembly.

34A.5.3.5 In the case of calibration prior to anchorage testing, the test rig, to which a mass of not less than 21.4 kg times the number of rear seating positions is rigidly attached, when subject to a velocity change of not less than 49 km/h, shall achieve within 30 milliseconds; a forward deceleration measured in the vicinity of a lap anchorage, within the range of 235 m/s<sup>2</sup> to 335 m/s<sup>2</sup> and shall maintain this deceleration, except for periods of less than 1 millisecond, for not less than 20 milliseconds.

34A.5.3.6 For upper anchorage testing, the test rig shall be operated in a manner identical in all operational aspects to that specified in Clause 34A.5.3.5 for rig calibration except that in this case the dummies replace the inert mass. The dummies shall be restrained in accordance with the requirements of Clause 34A.5.3.2.

34A.5.3.7 The upper anchorages shall withstand the loads imposed when tested in accordance with the dynamic test requirements of Clause 34A.5.3.6.

AUSTRALIAN DESIGN RULE NO. 34A - CHILD RESTRAINT ANCHORAGES

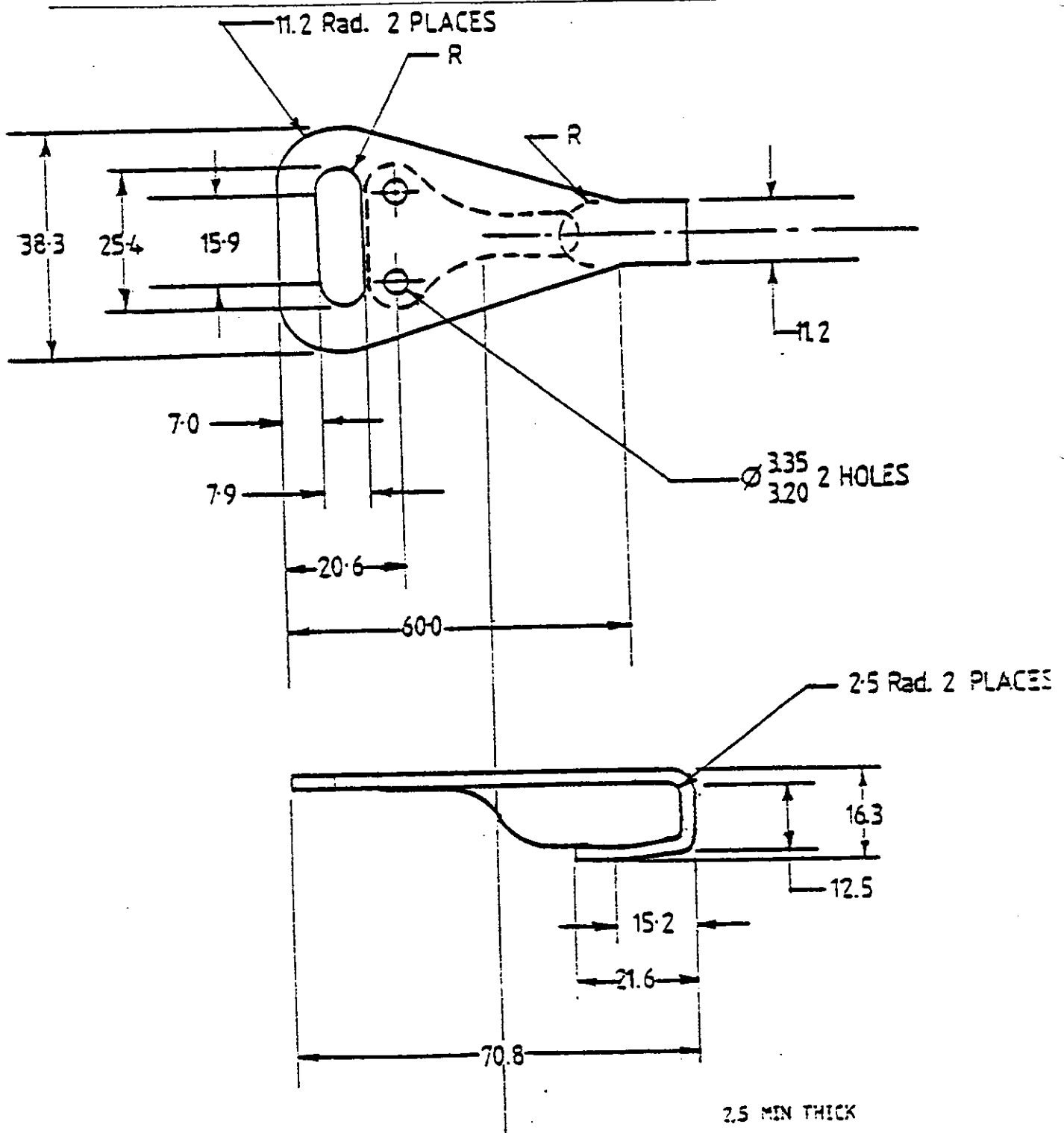

Figure 1 - CHILD RESTRAINT ATTACHING CLIP  
(include spring retainer)

SCALE 1:1

ALL DIMENSIONS in MM.

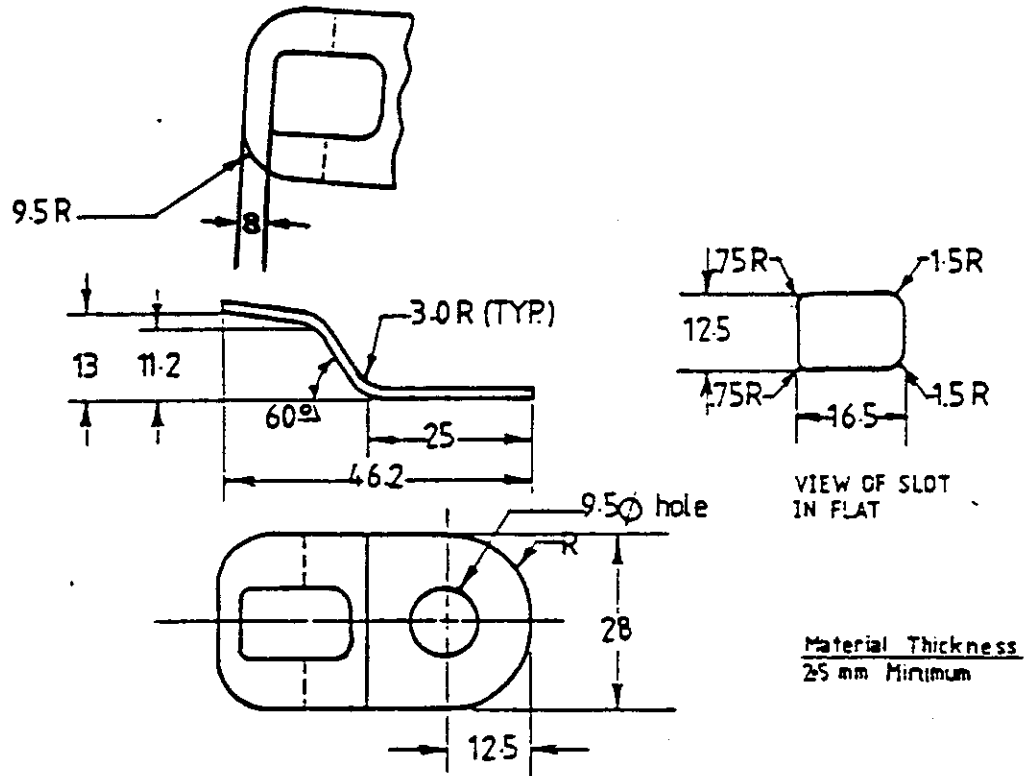

Figure 2. UPPER ANCHOR FITTING

SCALE 1:1  
All Dimensions in MM

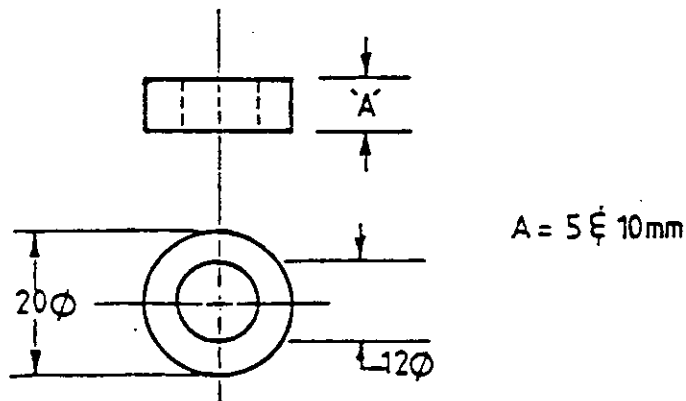

Figure 3. SPACER

SCALE 1:1  
All Dimensions in MM



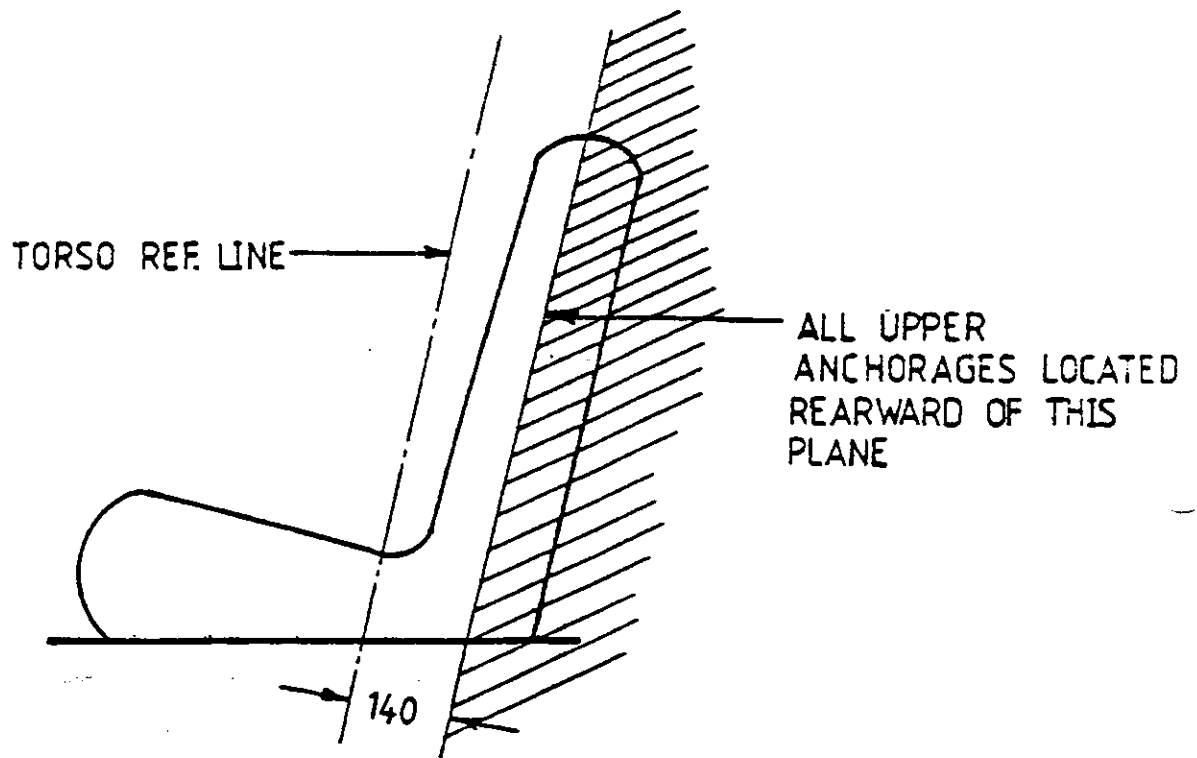
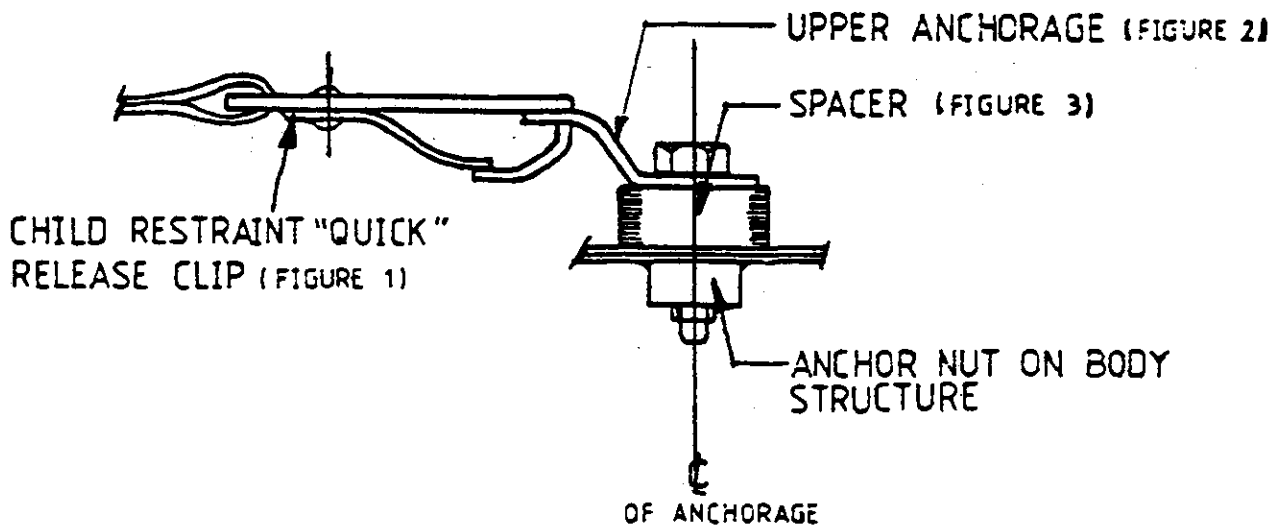

Figure 4. REAR SEAT

SCALE 1:10  
All Dimensions in M.M.



DRAWING OF CHILD RESTRAINT FITTING ASSEMBLY

NOT TO SCALE